

Sponsored by the Office of Naval Research (ONR)

ONR Decision-Support Workshop Series

The Human-Computer Partnership in Decision-Support

hosted by the

**Collaborative Agent Design Research Center (CADRC)
Cal Poly State University, San Luis Obispo, CA**

in conjunction with

**CDM Technologies, Inc.
San Luis Obispo, CA**

Proceedings of Workshop held on May 2-4, 2000

*at the
Embassy Suites Hotel
San Luis Obispo, CA*

September, 2000

Preamble

In August of 1998 the Collaborative Agent Design (CAD) Research Center of the California Polytechnic State University in San Luis Obispo, approached the Office of Naval Research (ONR) with the proposal for an annual workshop focusing on emerging concepts in decision-support systems for military applications. The proposal was considered timely by the ONR Logistics Program Office for at least two reasons. First, rapid advances in information systems technology over the past decade had produced distributed, collaborative computer-assistance capabilities with profound potential for providing meaningful support to military decision makers. Indeed, some systems based on these new capabilities such as the Integrated Marine Multi-Agent Command and Control System (IMMACCS) and the Integrated Computerized Deployment System (ICODES) had already reached the field testing and final product stages, respectively.

Second, over the past two decades the US Navy and Marine Corps have been increasingly challenged by missions demanding the rapid deployment of forces into hostile or devastated territories with minimum or non-existent indigenous support capabilities. Under these conditions Marine Corps forces have to rely mostly, if not entirely, on sea-based support and sustainment operations. Operational strategies such as Operational Maneuver From The Sea (OMFTS) and Ship To Objective Maneuver (STOM) are very much in need of intelligent, real-time and adaptive decision-support tools to assist military commanders and their staff under conditions of rapid change and overwhelming data loads.

In the light of these developments the Logistics Program Office of ONR considered it timely to provide an annual forum for the interchange of ideas, needs and concepts that would address the decision-support requirements and opportunities in combined Navy and Marine Corps sea-based warfare and humanitarian relief operations. The first ONR Workshop was held April 20-22, 1999 and focused on advances in technology with particular emphasis on an emerging family of powerful computer-based tools. The workshop concluded that the most able members of this family of tools appear to be computer-based agents that are capable of communicating within a virtual environment of objects and relationships representing the real world of sea-based operations. In this shared reality of the real world the agents reason collaboratively and interactively as they assist the users in the formulation of plans and the execution of resupply sequences. It was found that in particular such agents are useful for monitoring events, tracking the movement of cargo and transportation conveyances, alerting the users of supply shortages, generating mission and sortie schedules, and reporting on the current and projected future status of the sea-based logistics situation.

Following the success of the 1999 'Decision-Making Tools Workshop' the proposal for the theme and structure of the second ONR Workshop to be held on May 2-4, 2000, was seen as an opportunity for formalizing the concept of an annual ONR Decision-Support Workshop Series through the establishment of a set of objectives to serve as guiding principles for all future Workshops.

1. Subject to the availability of funding the ONR Decision-Support Workshops should be held annually, and should endeavor through their structure, format and content to be of approximately equal value to ONR, the contributors or presenters,

and the participants. ONR should be seen as the catalyst for bringing together experts and decision makers for an exchange of: user needs; technical approaches for satisfying these needs; and, new technical trends and state-of-the-art capabilities. Authors should be able to contribute their refereed papers within a stimulating intellectual environment that is on the one hand of the highest technical quality, and on the other hand sensitive to user needs and interests. Participants should be presented with an overview of the latest trends in the design, development and implementation of decision-support systems, at a technical level that is understandable by intelligent laypersons with either experience in or knowledge of military operations.

2. The Workshops should gradually evolve into a vehicle for establishing needs, directions, and opportunities that will be available to ONR as guidelines for the formulation of future funding policies and priorities.
3. The final product of each Workshop should be a document, in printed and/or electronic format, that will include not only the presented papers but also some useful record of forums and discussions held during the workshop.
4. The Workshop contributors should be required to abide by a process of paper submission and presentation that is clearly defined and disseminated in a timely manner.

In the context of the above guiding principles the Collaborative Agent Design Research Center proposed that the second annual ONR Workshop should convey the dual themes of evolving collaborative agent technology and end-user needs through the workshop title:

‘The Human-Computer Partnership in Decision-Support’

It was further proposed that the Workshop be structured in two parts: a relatively small number of selected formal presentations (i.e., technical papers) followed each afternoon by four concurrent open forum discussion seminars. To stimulate the open forum discussions it was suggested that the formal presentations should cover the Workshop theme conveyed by its title, from the following perspectives:

The Human Perspective

The Military Command and Control Perspective

The Military Logistics Perspective

The Military Intelligence Perspective

The Local Government and Commercial Perspective

The Research and Experimentation Perspective

The Technical Implementation Perspective

In concert with these formal presentations the following four open forum themes were identified for two afternoons followed by a summary session on the third and last day of the Workshop.

Theme A: Expeditionary Command and Control (C2) Users - focusing on differing user group requirements; customization of the user-interface; free format text and voice recognition; formalization of the data objectification process; rapid objectification of infrastructure data; and, human decision making skills and the role of training.

Theme B: Appropriate R&D Directions - integrating simulation and optimization techniques; integrating external applications; and, assessing uncertainty, risk and opportunity costs.

Theme C: System Design Requirements - broad system design guidelines; standardization and agent languages; the knowledge acquisition bottleneck; object-serving communication facilities; and, effective agent collaboration and planning.

Theme D: Communication Infrastructure - reliable data feeds; redundancy and graceful degradation; alternatives for the 'last mile'; and, access authentication and security.

During the actual Workshop each open forum seminar was led by a Marine Corps officer taking the role of facilitator. A summary of these forum discussions which took place on the first two days of the Workshop are included in these proceedings.

The proceedings are divided into two sections. Section One contains the formal presentations that were scheduled on the three mornings of the Workshop. Only some of these contributions are in the standard format of a scientific paper. The majority of the formal contributions were presented by past, present and potential future users of decision-support systems who preferred a slide format that more accurately reflects their primarily *operational* comments and concerns.

Jens Pohl, Ph.D.

Executive Director

Collaborative Agent Design Research Center

Anthony Wood (Col. USMC Ret.)

Vice President

CDM Technologies, Inc.

San Luis Obispo, California

September, 2000

Foreword to the 2nd Annual ONR Workshop

Foreword

The Decision Support Workshop of May 2-4, 2000 held in San Luis Obispo, Cal., was the second in a series that was started one year earlier as a joint project of the Office of Naval Research and the Collaborative Agent Design Research Center of Cal Poly.

The goal of this series of Workshops is to provide a forum where connections can be established on one hand between developers and proponents of decision support tools, with potential users such as managers of large, complex organizations/systems on the other. Clearly, the military belong to this class of users and it is therefore not surprising that ONR has a vested interest in promoting research in this particular field. It is also clear that the class of potential users is not restricted to the military - in fact civilian government bodies as well as business and industry entities should be strongly interested in adopting these tools (and their future refinements) for their own specific purposes. The list of the speakers and the topics presented during the Workshop does indeed attest to the variety of areas where decision support systems are already in use.

This Workshop has concentrated on the human-computer interaction. Although computers are after all man-made devices, there is a peculiarity in the way humans interact with a computer that has no parallel in human-human interactions. This was brought out in an interesting talk by Dr. Ron DeMarco. Other areas where computers play a major role included the topic of how information is handled, secured, and assured. Since the basis of all decision making is accurate, uncontaminated information, this is a very important topic that was excellently treated by Mr. Steve York and Ms. Virginia Wiggins in their presentations. Other highlights included a thought-provoking talk by RADM C. L. Munns that raised many questions concerning decision support in the Fleet. An interesting description of the risks of misusing information technology was given, with his usual verve, by Dr. Gary Klein. The reader of these Proceedings will find other excellent discussions of decision support systems, in particular the agent-based ones described by the senior staff of CADRC.

It is a pleasure to thank, on behalf of ONR, the distinguished speakers, demonstrators and attendees, who have contributed greatly to the success of the

Workshop and have provided new insights into the complex interplay between humans, computers, information technology, and decision making.

Last, but not least, particular thanks are due to Prof. Jens Pohl and Col. Tony Wood, and their respective staffs at Cal Poly and CDM Technologies, Inc.

Through their efforts they created a very pleasant atmosphere that helped the Workshop in becoming a success.

I look forward to the third Workshop in this series that will take place in May 2001.

Phillip B. Abraham
Logistics Program Officer
Office of Naval Research

October 2000

Table of Contents

Preamble	iii
Foreword to the 2 nd Annual ONR Workshop	vii
Table of Contents	ix
Decision-Support Workshop Program	xi
About the Speakers	xv
<i>Section One: Formal Presentations</i>	1
The Human-Computer Partnership	3
Ronald A. DeMarco, Ph.D., Associate Technical Director, ONR	
A Rifle Range for the Mind	9
James A. Lasswell (Col. USMC Ret.), Senior Analyst GAMA Corporation	
The Present and Future Role of Information Security, Infrastructure Assurance Issues, and the FBI's National Infrastructure Protection Center	15
Steve York, Intelligence Operations Specialist, National Infrastructure Protection Center, Federal Bureau of Investigation (FBI)	
The Marine Corps Warfighting Laboratory: Experiments in Progress	25
John Allison (Lt.Col. USMC Ret.), Director, Program Integration Marine Corps Warfighting Laboratory	
ELB ACTD: Speeding Technology to the Warfighter	37
Ray Cole (Col. USMC Ret.), Demonstration/Program Manager, Extending the Littoral Battlespace ACTD, ONR	
IMMACCS and the Experience of the SPMAGTF(X)	49
Col. Robert Schmidle, Commanding Officer, Special Purpose Marine Air Ground Task Force (Experimental)	
Decisions: Fleet Perspective	59
RADM Charles L. Munns, USN, Deputy Chief of Staff for C4I, Resources, Requirements and Assessments, CINCPACFLT	
Measuring the Human Dimension in Information Superiority	73
Richard E. Hayes, Ph.D., Chief Scientist Cooperative C4ISR Research Program (CCRP) and President, Evidence Based Research Inc.	
Tactical Communications and Networking: The Last Mile	

Challenge	89
Jeffrey S. Ribel, Systems Analyst, Adroit Systems Inc.	
Information Representation Basis of Decision Support Systems	99
Russell Leighton, Senior Software Engineer, Collaborative Agent Design Research Center, Cal Poly State University, San Luis Obispo, CA	
ICDM: A Development and Execution Framework for Agent-Based, Decision-Support Systems	107
Kym Jason Pohl, Senior Software Engineer, Collaborative Agent Design Research Center, Cal Poly State University, San Luis Obispo, CA	
Object Based Communications for Distributed Collaborative Decision Support Systems	121
Thomas McVittie, Ph.D., Principal Software Engineer, Mission Software Systems, Jet Propulsion Laboratory, California Institute of Technology	
Some Risks of Misusing Information Technology	133
Gary Klein, Ph.D., Chief Scientist, Klein Associates Inc.	
The Role of Decision-Support in Logistics Command and Control	141
Michael J. Badger, Command and Control Directorate, CECOM, USA	
Information Assurance and Joint Theater Distribution System Vulnerabilities	153
Virginia Wiggins, Study Director, Joint C4ISR Decision Support Center, Office of the Assistant Secretary of Defense for Command, Control, Communications, and Intelligence (OASDC31)	
Computational Intelligence for Decision Support	177
Russell C. Eberhart, Ph.D., Associate Dean for Research , Purdue School Of Engineering and Technology, Indiana University Purdue University, Indianapolis (UPUI)	
<i>Section Two: Open Forum Seminars</i>	187
Theme A: Expeditionary Command and Control (C2) Users	189
Theme B: Appropriate R&D Directions	193
Theme C: System Design Requirements	195
Theme D: Communication Infrastructure	197

ONR / CADRC Decision-Support Workshop

May 2-4, 2000

The Office of Naval Research and the Collaborative Agent Design Research Center, California Polytechnic State University, San Luis Obispo



Tuesday, May 2nd

TIME	ACTIVITY
7:30	Registration Begins Registration desk open from 7:30 AM until 5:00 PM.
8:00 - 8:10	Welcome by Anthony A. Wood (Col. USMC, Ret.), Director of Applied Research, Collaborative Agent Design (CAD) Research Center.
8:15 - 8:45	<i>"The Human-Computer Partnership"</i> Ronald A. DeMarco, Ph.D. (Keynote Speaker) Associate Technical Director, Office of Naval Research.
8:45 - 9:30	<i>"The Role of Decision Ranges in Enhancing Human Decision Making"</i> James A. Lasswell , Senior Analyst, GAMA Corporation.
9:30 - 10:15	<i>"The Present and Future Impact of Information Security on National Infrastructure Assurance Issues"</i> Steve York , Intelligence Operations Specialist, National Infrastructure Protection Center, FBI.
10:15 - 10:30	Break
10:30 - 11:05	<i>"The Marine Corps Warfighting Laboratory: Experiments in Progress"</i> John Allison , Director, Program Integration, Marine Corps Warfighting Laboratory.
11:05 - 11:40	<i>"Extending the Littoral Battlespace ACTD: Speeding Technology to the WARFIGHTER"</i> Ray Cole , Demonstration/Program Manager, Extending the Littoral Battlespace ACTD.

Tuesday, May 2nd ~ continued

TIME	ACTIVITY
11:40 - 12:15	<i>“IMMACCS and the Experience of the SPMAGTF(X)”</i> Col. Robert Schmidle, Commanding Officer, Special Purpose Marine Air Ground Task Force (Experimental).
12:15 - 1:15	Luncheon
1:30 - 3:00	First Afternoon Session
3:00 - 3:15	Break
3:15 - 4:45	Second Afternoon Session
4:45	Afternoon Sessions Conclude

Wednesday, May 3rd

TIME	ACTIVITY
7:30	Registration desk open from 7:30 AM until 5:00 PM.
8:00 - 8:45	<i>“Decision-Support and the Fleet”</i> RDML Charles L. Munns, USN (Keynote Speaker) Deputy Chief of Staff for C4I, Resources, Requirements and Assessments, CINCPACFLT (Commander in Chief, US Pacific Fleet) (N6N8).
8:45 - 9:30	<i>“Measurement: The Human Dimension in Information Superiority”</i> Richard E. Hayes, Ph.D., President, Evidence Based Research, Inc. Senior Scientist, C4ISR Cooperative Research Program (CCRP) at the Office of the Assistant Secretary of Defense for C3I.
9:30 - 10:15	<i>“Tactical Communications and Networking: The Last Mile Challenge”</i> Jeffrey Ribel, Systems Analyst, Adroit Systems, Inc.
10:15 - 10:30	Break
10:30 - 11:05	<i>“The Information Representation Basis of Decision-Support Systems”</i> Russell Leighton, Senior Software Engineer, Collaborative Agent Design Research Center, Cal Poly, San Luis Obispo.
11:05 - 11:40	<i>“Generation of Agent-Based, Decision-Support Systems Based On Ontological Systems”</i> Kym Pohl, Senior Software Engineer, Collaborative Agent Design Research Center, Cal Poly, San Luis Obispo.

Wednesday, May 3rd ~ continued

TIME	ACTIVITY
11:40 - 12:15	<i>“Object-Based Communication Services in Support of Decision-Support Systems”</i> Thomas McVittie, Ph.D. , Principal Software Engineer, Mission Software Systems, Jet Propulsion Laboratory, California Institute of Technology.
12:15 - 1:15	Luncheon
1:30 - 3:00	First Afternoon Session
3:00 - 3:15	Break
3:15 - 4:45	Second Afternoon Session
4:45	Afternoon Sessions Conclude
5:00 - 7:00	Reception

Thursday, May 4th

TIME	ACTIVITY
7:30	Registration desk open from 7:30 AM until noon.
8:00 - 9:00	<i>“Some Risks of Misusing Information Technology”</i> Gary Klein, Ph.D. (Keynote Speaker) Chief Scientist, Klein Associates, Inc.
9:00 - 9:45	<i>“The Role of Decision-Support in Logistics Command and Control”</i> Michael Badger , Logistics Command and Control Advanced Technology Demonstration Manager for the Command and Control Directorate; Research, Development, and Engineering Center; and, the Communications and Electronics Command (of the US Army).
9:45 - 10:00	Break
10:00 - 10:45	<i>“Information Assurance for the Joint Theater Distribution Environment”</i> Virginia Wiggins , Study Director, Joint C4ISR Decision Support Center. Located in the Office of the Assistant Secretary of Defense for Command, Control, Communications, and Intelligence (OASDC31). Owned by the Senior Steering Group: Under Secretary of Defense for Acquisition, Technology, and Logistics (USD AT&L), OASDC31 and the Vice Chairman of the Joint Chiefs of Staff (VCJCS).

Thursday, May 4th ~ continued

TIME	ACTIVITY
------	----------

10:45 - 11:15	<i>“Computational Intelligence for Decision Support”</i> Russell C. Eberhart, Ph.D. , Associate Dean for Research, Purdue School of Engineering and Technology, Indiana University Purdue University Indianapolis (IUPUI).
---------------	---

11:15 - 12:15	Summary Plenary Session
---------------	--------------------------------

12:15 - 1:15	Concluding Luncheon
--------------	----------------------------

ACTIVITY LOCATIONS

Registration Desk	Atrium Foyer ~ May 2nd Edna Foyer ~ May 3rd and 4th
--------------------------	--

Presentations	San Luis Obispo Room North ~ May 3rd, 4th, 5th
----------------------	---

Afternoon Sessions	There are four breakout rooms for the afternoon sessions of May 2nd and 3rd. These rooms are color coded. Please match the color code on your name tag to the room listed below:
---------------------------	--

<u>Room</u>	<u>Color</u>
Del Mar	Blue
Edna East	Yellow
Los Osos North	Red
Los Osos South	Green

Luncheons	Atrium ~ May 3rd, 4th, 5th
------------------	-----------------------------------

Reception	Atrium ~ May 3rd
------------------	-------------------------

About the Speakers

David Alberts, Ph.D.

Dr. Alberts is the Director of Research, OASD (C3I). Previously, he served as the Director of Information Systems Engineering at the Mitre Corporation, a federally funded research and development center. Prior to this, he worked as the Director of Advanced Concepts, Technologies, and Information Strategies (ACTIS), Deputy Director of the Institute for National Strategic Studies, and the Executive Agent for DoD's Command and Control Research Program. This included responsibility for the Center for Advanced Concepts and Technology (ACT) and the School of Information Warfare and Strategy (SIWS) at the National Defense University. He has more than 25 years experience developing and introducing leading-edge technology into private and public sector organizations. This extensive applied experience is augmented by a distinguished academic career in Computer Science and Operations Research and Government service in senior policy and management positions.

Dr. Alberts' experience includes serving as a CEO for a high-technology firm specializing in the design and development of large, state-of-the-art computer systems (including expert, investigative, intelligence, information, and command and control systems) in both government and industry. He has also led organizations engaged in research and analysis of command and control system performance and related contributions to operational missions. Dr. Alberts has had policy responsibility for corporate computer and telecommunications capabilities, facilities, and experimental laboratories. His responsibilities have also included management of research aimed at enhancing the usefulness of systems, extending their productive life, and developing improved methods for evaluating the contributions that systems make to organizational functions. Dr. Alberts frequently contributes to government task forces and workshops on systems acquisition, command and control, and systems evaluation.

Dr. Alberts' academic career has included serving as first Director of the Computer Science Program at NYU. He has held professional rank posts at NYU Graduate School of Business and at the CUNY as well as chaired numerous sessions at both international and national conferences. In addition, he has many publications, some of which are included in tutorials given by the IEEE and other professional societies. He earned his Ph.D. in Operations Research at the University of Pennsylvania in 1969.

John Allison Director of Program Integration Marine Corps Warfighting Laboratory

Lieutenant Colonel Allison was born in Jefferson City, Missouri and joined the Marine Corps Platoon Leaders Commissioning Program in January of 1976. He received his commission in 1979. He holds a Bachelor of Science Degree from Southwest Missouri State University and is a graduate of the US Army's Armor Officer Advance Course Ft Knox, Kentucky and their Command and General Staff College, Ft. Leavenworth, Kansas. In May of 1995, he graduated from the US Marine Corps School of Advance Warfighting Marine Corps University in Quantico, Virginia.

During the early phase of the Tanker Wars in the Persian Gulf, he served as the Executive and Guard Officer of the Marine Detachment of the USS Kitty Hawk, CV-63. In 1985, he commanded the first line company of Light Armored Vehicles for the 1st Marine Division. In 1990, he returned to the Persian Gulf and served with Task Force Pappa Bear, 1st Marine Division (Rein) supporting the 1st Combat Engineer Battalion (-) as the OIC of Obstacle Clearing Detachment II. He became the 3rd Assault Amphibian Battalion Operations Officer upon his return from the Gulf War.

In February of 1992, he was assigned as the Assistant G-3 Operations Officer for the 1st Marine Division. He served as the G-3 Operations Officer for Special Purpose Marine Air Ground Task Force, Los Angeles during the LA riots in May 1992. In December 1992, he deployed to Somalia and served on the Marine Forces Somalia Staff as a G-3 planner, operations officer, and force protection specialist. Furthermore, in January 1995, he returned to Somalia as a member of the C-3 Future Operations and Current Operations Sections, Combined Task Force United

Shield. After his return from Somalia, he served on the staff of the Marine Air Ground Task Force Staff Training Program working as the joint and component branch head.

Prior to his retirement, Lieutenant Colonel Allison served as the Director of the Experimental Operations Division for the Marine Corps Warfighting Lab, Quantico, Virginia during the Urban Warrior series of experiments.

His decorations and awards include the Legion of Merit, Bronze Star with "V", Purple Heart, Meritorious Service Medal, Joint Service Commendation Medal, Navy Commendation Medal, Navy Achievement Medal, and Combat Action Ribbon.

Lieutenant Colonel Allison is married to the former Susan O'Donnell of St. Louis, Missouri. They have three children, Amanda, Stephanie, and John, Jr. He is currently an IPA from Pennsylvania State University serving as the Director of Program Integration for the Marine Corps Warfighting Laboratory.

Michael Badger
Log C2 ATD Manager
C2D, RDEC, CECOM

Michael Badger is the Logistics Command and Control Advanced Technology Demonstration (Log C2 ATD) Manager for the Command and Control Directorate (C2D); Research, Development, and Engineering Center (RTEC); and, the Communications and Electronics Command (CECOM) (of the US Army). During the workshop, he will discuss the role of decision support in logistics command and control.

Ray Cole
Demonstration/Program Manager
Extending the Littoral Battlespace ACTD

Raymond Cole was born in Philadelphia, Pennsylvania. He enlisted in the Marine Corps and was commissioned in November 1971 after graduating with a Bachelor of Arts Degree in Economics from Virginia Polytechnic Institute and State University in Blacksburg, Virginia.

Mr. Cole served in a variety of command and staff positions with the 1st and 2nd Marine Divisions for almost eleven years. Subsequent tours included: Executive Officer, Marine Detachment, USS Saratoga, Instructor Amphibious Warfare School, and Executive Officer of Basic School Classes 5-79 and 3-80.

From July 1980 to July 1983, Mr. Cole served with the 2nd Marine Division, initially with 2nd Battalion, 8th Marines as a Rifle Company Commander and Battalion Operations Officer, and then, as the Regimental Operations Officer, 8th Marines. He twice deployed to the Mediterranean and participated in operations to evacuate the Palestine Liberation Organization from Lebanon and in the subsequent peacekeeping mission.

Mr. Cole served as a Ground Combat Analyst at Headquarters Marine Corps from July 1984 to July 1987. He transferred to the Basic school in July 1987 and served as the Tactics Group Chief until July 1989.

In August 1990, Mr. Cole began his second tour with the 1st Marine Division, serving as the Division Operations Officer during Operations Desert Shield and Storm. After the war, he commanded the 1st Light Armored Infantry Battalion and served as a Battalion Commander in Los Angeles during the 1992 Riots. He assumed duties as the Division G-3 in 1992 and deployed to Somalia in December 1992 in support of Operation Restore Hope. Then, Colonel Cole commanded 1st Marine Regiment from July 1993 until January 1995 when he assumed interim duties as the Chief of Staff, I Marine Expeditionary Force.

Mr. Cole returned to Washington DC in June of 1995 and served as the Chief, Land and Littoral Warfare Joint Warfighting Capabilities Assessment Division, J-8, the Joint Staff. During this tour, Mr. Cole served as the Co-

Executive Secretary for the 1996 Defense Science Board and the Modernization Panel Chief for the 1996 Quadrennial Defense Review.

During his active service, Mr. Cole attended the Marine Corps' Amphibious Warfare School and Command and Staff College and the National War College at Fort McNair during academic year 1989-1990. Mr. Cole received personal decorations that include the Defense Superior Service Award, Legion of Merit with Gold Star and Combat Distinguishing Device, Meritorious Service Medal with Gold Star, Navy Commendation Medal, Navy Achievement Medal, and Combat Action Ribbon. In 1991, Mr. Cole was awarded the Navy League's "Holland M. Smith Award" for Operational Competence.

Mr. Cole retired from the Marine Corps in 1997 and joined Booz Allen & Hamilton where he worked as a Consultant to both the ELB ACTD and the Urban Warrior AWE. In June 1999, Mr. Cole assumed his present responsibilities as the Program/Demonstration Manager for the ELB ACTD. Mr. Cole serves in his present position as an IPA from the Potomac Institute for Policy Studies.

Mr. Cole is married to the former Dianne Casteel of Virginia Beach, Virginia. They have one daughter, Adrian, and three sons: Brian, Adam, and Mark.

Ronald A. DeMarco, Ph.D.
Associate Technical Director
Office of Naval Research

Dr. DeMarco is a native of New Jersey. He completed a Masters Degree in Synthetic Organic Chemistry and a Ph.D. in Synthetic Fluorine Chemistry at the University of Idaho.

In 1972, he began his Naval career at the Naval Research Laboratory in the Chemistry Division where he worked on the synthesis and chemistry of compounds ranging from high-density gyro fluids, advanced oxidizers, electrically conducting polymers, and non-linear optical polymers to IR countermeasures and chemically-generated oxygen for emergency breathing devices. While at NRL, he headed the Inorganic Chemistry and Advanced Materials sections. In 1984, he took a one-year rotational assignment to the Naval Sea Systems Command's R&D office where he directed research in ship and submarine Hull, Machinery, and Electrical systems as well as ship and submarine environmental programs. After returning to NRL, the NAVSEA effort continued on a part-time basis until 1990.

In 1990, he joined the Office of Naval Research as the Director of Chemistry. Since then, he has held the positions of Director of Physical Sciences and Head of Engineering, Materials, and Physical Sciences which encompasses physical and materials sciences, environmental programs, logistics, undersea weaponry, fluid dynamics, energetic materials, and ship and submarine systems. Since September 1999, he has served as Associate Technical Director at ONR. In addition, he has authored over 30 published scientific papers, over 40 technical reports, and over 50 technical presentations based on his research.

Russell C. Eberhart, Ph.D.
Associate Dean for Research
Purdue School of Engineering and Technology

Russell C. Eberhart is the Associate Dean for Research at the Purdue School of Engineering and Technology, Indiana University Purdue University Indianapolis (IUPUI). He is also Director of the Biomedical Research and Development Center and Professor of Electrical and Computer Engineering. He received his Ph.D. from Kansas State University in electrical engineering. In addition, he is co-editor of a book on neural networks, now in its fifth printing and co-author of Computational Intelligence PC Tools, published in 1996 by Academic Press. Currently, he is finishing revisions to a book with Jim Kennedy and Yuhui Shi entitled *Swarm Intelligence*, to be published by Morgan Kaufmann/Academic Press, in October 2000. Furthermore, he is Associate Editor of the IEEE Transactions on Evolutionary Computation and was recently awarded the IEEE Third Millennium Medal.

Richard Hayes, Ph.D.
President
Evidence Based Research, Inc.

As President and founder of Evidence Based Research, Inc. (EBR), Dr. Hayes specializes in multidisciplinary analyses of intelligence and national security issues; the identification of opportunities to improve support to decision makers in the defense and intelligence communities; the design and development of support systems; and, the criticism, testing, and evaluation of systems and procedures that provide such support.

His areas of expertise include crisis management; political-military issues; research methods; simulation and modeling; test and evaluation; military command, control communication, and intelligence (C3I); and decision aiding systems. Since coming to Washington in 1974, Dr. Hayes has established himself as a leader in bringing the systematic use of evidence and the knowledge base of the social sciences into play in support of decision makers in the national security community, domestic agencies, and major corporations. He has initiated several programs of research and lines of business that achieved national attention and many others that directly influenced policy development in client organizations. Dr. Hayes serves as the Senior Scientist to the C4ISR Cooperative Research Program (CCRP) at the Office of the Assistant Secretary of Defense for C3I.

Gary Klein, Ph.D.
Chief Scientist
Klein Associates, Inc.

Gary Klein, Ph.D., is Chief Scientist of Klein Associates Inc., a company he founded in 1978 to better understand how to improve decision making in individuals and teams. The company has 25 employees working on projects for government (e.g., Army, Navy, Air Force, Marines, NASA, NIH) and commercial clients (e.g., Mead Johnson, Kodak, McKinsey, and Procter & Gamble). Dr. Klein is one of the founders of the field of Naturalistic Decision Making. His work on recognition decision-making has been influential for the design of new systems and interfaces, and for the development of decision training programs. He has extended his work on decision making to describe problem detection, option generation, and planning. In order to perform research on decision-making in field settings, Dr. Klein and his colleagues have developed new methods of Cognitive Task Analysis. Then for improving performance, Klein Associates has used Cognitive Task Analysis methods to study decision making in more than 60 domains, including firefighting, command and control, software troubleshooting, healthcare, and consumer purchasing. Dr. Klein has presented workshops on Cognitive Task Analysis to more than 300 professionals in the U.S. and abroad and has presented seminars on Naturalistic Decision Making to a wide variety of groups such as the Smithsonian Associates program.

Dr. Klein received his Ph.D. in experimental psychology from the University of Pittsburgh in 1969. He taught at Oakland University (1970-1974) and worked as a research psychologist for the U.S. Air Force (1974-1978). He has written more than 70 papers and edited two books (with a third in press). He is the author of *Sources of Power: How People Make Decisions* (1998, MIT Press), which has sold more than 8,000 copies and is being translated into two languages. The book has been favorably reviewed in a wide variety of publications, including *Nature*, the *Wall Street Journal*, and the *Marine Corps Gazette*.

James A. Lasswell
Senior Analyst
GAMA Corporation

James A. Lasswell has been the senior analyst for GAMA Corporation since June 1998. In this capacity, he has been responsible for a series of advanced concept wargaming as well as supporting the development of the Collin's Combat Decision Range under contract for the Marine Corps Warfighting Laboratory (MCWL).

A retired U.S. Marine Corps Colonel, he was the Head of Experimental Operations at MCWL and served as Experiment Control for the seminal Hunter Warrior Advanced Warfighting Experiment during March 1997. In addition, he has over 10 years military experience in political, military, and strategic plans positions including serving as the Head of the Commandant's Staff Group, as well as additional duties that included serving as Co-chairman of two Office of the Secretary of Defense sponsored Revolution in Military Affairs Task Forces. Mr. Lasswell was the Marine Corps author for the Naval Services' strategic concept document titled *Forward . . . From the Sea* and is a frequent contributor to professional journals on future technology and conceptual issues.

Russell Leighton
Senior Software Engineer
Collaborative Agent Design Research Center

Russell Leighton is a software engineer at the Collaborative Agent Design Research Center (CADRC), Cal Poly in San Luis Obispo. He has a Bachelor degree in Aeronautical Engineering from Cal Poly and a Master degree in Engineering Mechanics from the University of Texas at Austin. He was employed at the Phillips Laboratory, Edwards Air Force Base, California (1981-1997) as a Materials Research Engineer assigned to assess and develop computational tools for the analysis of solid rocket motor structural integrity. His current responsibilities at the CADRC include technical leader for the Integrated Marine Multi-Agent Command and Control System (IMMACCS) team and co-technical leader for the Integrated-Cooperative Decision Model (ICDM) Toolkit development project.

Thomas McVittie
Principal Software Engineer
NASA Jet Propulsion Laboratory

Thomas McVittie is a principal software engineer at NASA's Jet Propulsion Laboratory. His research interests include highly reliable object-based distributed systems and fault tolerant system architectures.

McVittie has a Ph.D. in Electrical and Computer Engineering from the University of California at Santa Barbara. He is the systems architect for the Defense Information Infrastructure (DII) Common Operating Environment (COE) Kernel and the principal designer of the Shared Net, which is an object-based information sharing system designed for the USMC.

RDML Charles L. Munns, USN
Deputy Chief of Staff for C4I, Resources, Requirements, and Assessments

Rear Admiral Munns assumed his current duty as Deputy Chief of Staff for C4I, Resources, Requirements, and Assessments, Commander in Chief, U.S. Pacific Fleet on 1 April 1998. As N6N8, he acts as Chief Financial Officer and Chief Information Officer for CINCPACFLT.

Rear Admiral Munns began his Naval career at the U.S. Naval Academy graduating with distinction in 1973 with a Bachelor of Science Degree, majoring in Physics. Subsequently, he earned a Master of Science in Computer Science from the University of Colorado.

During his military service, he has served on five submarines. His first command assignment was as Commanding Officer of USS RICHARD B. RUSSELL (SSN 687), and his second was a major command as Commander Submarine Development Squadron TWELVE.

Rear Admiral Munns has served duty in the Pentagon working in International Negotiations and was selected for a one-year fellowship on Navy's Strategic Studies Group where his task was to create innovative operational concepts for Naval Operations in 2025 and beyond.

Kym Pohl
Senior Software Engineer
Collaborative Agent Design Research Center

Kym Pohl is a Senior Software Engineer at the Cal Poly CADRC (Collaborative Agent Design Research Center). In addition to providing technical consultation on a number of projects, Kym currently provides technical leadership for the SEAWAY maritime logistics project, the FCADS Command and Control System, and the ICDM project. Kym holds Bachelor of Science and Master of Science degrees in Computer Science and a Master of Science degree in Architecture. His research interests are in the application of agent-based decision-support theory.

Jeffrey Ribel
Systems Analyst
Adroit Systems, Inc.

Jeffrey Ribel is currently a Systems Analyst with Adroit Systems, Inc. in Alexandria, Virginia. He is a Communications and Data Systems officer in the Marine Corps Reserve, and most recently, served on active duty as a C4I Systems Project Officer in the C4ISR Branch of the Marine Corps Warfighting Laboratory. His previous billets include Marine Communications Detachment Officer-in-Charge and Technical Control Officer on an LHD class ship and S-6/Communications Platoon Commander at a Tank Battalion. His interests include all aspects of technology and their application to business, government, and military practices and organizations.

Col. Robert E. Schmidle
Commanding Officer
Special Purpose Marine Air Ground Task Force

Colonel Schmidle is a native of Newtown, Connecticut. He graduated from Drew University in 1975 with a B.A. degree in History. He is a Distinguished Graduate of both the Marine Corps Command and Staff College, 1992, and the Marine Corps War College, 1996.

Colonel Schmidle's command positions include Commanding Officer of Marine Fighter Attack Squadron 251 and Commanding Officer of Marine Fighter Attack Squadron 115. Currently, he is the Commanding Officer of the Special Purpose Marine Air Ground Task Force (Experimental) of the Marine Corps Warfighting Lab.

His other assignments include Operations Officer and Air Officer of 1st Battalion 9th Marines; Maintenance Officer, Operations Officer and Executive Officer of Marine Fighter Attack Squadron 333; Operations Officer and Executive Officer of Marine Aircraft Group 31; and, Second in Command of Special Purpose Marine Air Ground Task Force (Experimental). Colonel Schmidle has also served as a facility advisor at the Marine Corps Command and Staff College.

His personal awards include the Distinguished Flying Cross with Combat 'V', Meritorious Service Medal, Air Medal with numeral 6, and the Navy and Marine Corps Commendation Medal with one gold star in lieu of second award.

Colonel Schmidle is married to the former Pamela Jutkus of Westfield, MA. They have two sons, Nicholas and Christian.

Virginia Wiggins
Study Director
Joint C4ISR Decision Support Center

Ms. Virginia Wiggins is a Study Director for the Joint C4ISR Decision Support Center. She has experience in both private industry and DoD. She began her career as an RF design engineer with Boeing Aerospace, focusing on missile system design, testing, and integration. In the course of her work in private industry, she dealt with both Air and Land missile systems such as Patriot, HAWK, Pershing, Army TACMS, and the Multiple Launch Rocket System. After 10 years of experience in design and systems integration, she joined the DoD in the Software Engineering Directorate of the US Army Missile Command, in Huntsville, Alabama. There, she specialized in Air Defense Command and Control hardware and software integration. In early 1991, she was detailed to Saudi Arabia, where she headed a joint team of military and civilian personnel in integrating the Patriot system into the Royal Saudi Air Defense Forces. Subsequent to this assignment, she moved to the Ballistic Missile Defense Organization, where she headed a joint team developing operational and technical architectures for air and missile defense.

In 1997, she joined the Joint C4ISR Decision Support Center. She has completed two major studies successfully, one focused on evaluating the military utility of SATCOM and Unmanned Aerial Vehicles in the role of communications relay platforms. Furthermore, she completed a Logistics Information Assurance study for the Joint Theater Distribution System and plans to brief the results of this latest effort during the workshop.

Steve York
Intelligence Operations Specialist
National Infrastructure Protection Center (FBI)

Steve York joined the FBI's National Infrastructure Protection Center (NIPC) in 1998 as a senior professional support staffer, filling the position of an Intelligence Operations Specialist. He manages the FBI's Key Asset Initiative, a new National Security program implemented under Presidential Decision Directive 63. Under this effort, FBI Headquarters and each of the 56 field offices are working with the owners and operators of business enterprises and utilities as well as officials responsible for public safety to ensure the ability of those entities to reliably deliver essential services in the face of a cyber attack that has either national, regional, or local implications.

Prior to joining the FBI's NIPC, from 1997 through 1998, Mr. York served as a senior policy analyst for the President's Commission on Critical Infrastructure Protection (PCCIP). In 1996, Mr. York retired after nearly 25 years of active duty with the US Marine Corps, where as a Marine aviator he served with distinction. He led and commanded Marines in the Fleet Marine Force and served on the Joint Staff during the tenure of General Colin Powell. Mr. York is no stranger to the West Coast, having served two tours at Naval Air Station Whidbey Island, flying EA-6B Prowler aircraft out of the upper Puget Sound airfield.

Mr. York's wife, Debra, DePauw '74, is the Director of recruiting for the Navy Federal Credit Union. The Yorks have two daughters. The eldest, Vanessa, a '99 Virginia Tech grad, presently works for the American Bankruptcy Institute in Alexandria VA. The youngest, Alexis, is successfully finishing her freshman year at the University of Oregon.

In addition, Mr. York graduated from Wabash College in 1972, the Naval War College, and holds several graduate degrees, most notably a Masters degree from the Fletcher School of Law and Diplomacy. Finally, he earned a Masters degree in Education and is certified to teach in the states of Virginia and Washington.

Sponsored by the Office of Naval Research (ONR)

ONR Decision-Support Workshop Series

The Human-Computer Partnership in Decision-Support

Section One: *Formal Presentations*

The HUMAN-COMPUTER PARTNERSHIP

Ronald A. DeMarco, Ph.D.
Associate Technical Director, ONR

Good morning, and thank you for inviting me to this workshop. Being a chemist, trying to define a “human-computer partnership” so I would know what to talk about, was a challenge. So I went to our experts for guidance. I spoke to our Human Systems folks and well, I had the impression that computers are tools for humans. You don’t really “partner” with tools. We have to ‘harness their power’ and ensure that they serve us. I spoke with our computer people to see their perspective, and walked away with the impression that computers are more like an extension of us; having the ability to do things we can’t do but, much more along the lines of being part of the team rather than apart from the team.

I’m still not sure I understand the “partnership”. What I’d like to do is to provide you with an S&T perspective of my sense of how I see humans and computers working and with a focus on the DD-21, then look at some specifics relating to one of our “Future Naval Capabilities”, Decision Support Systems. I think it’s the easiest way to see how we have “partnered” with the computer and finish-up with some myths and issues we still have to be concerned with during this partnership.

First of all, how the Navy “partners”, “interacts” or uses computers and the how naval personnel relate to their computers is crucial to making tomorrow’s sailors and marines tactically smarter than any future enemy will be. As Secretary of the Navy, Richard Danzig has said...”We need 21st century platforms doing 21st century things.” The ability of computers to enable information technology and decision aids to accomplish that goal is crucial.

As I see the future mission for the Naval Forces, it will focus on influencing events near the shore rather than in the open sea. We will be operating under a concept that we call “Network Centric Warfare”. Simply, from a platform perspective that means that platforms will serve as critical nodes in a larger network composed of intelligence, surveillance and reconnaissance assets, and weapon delivery systems. Every operator serving within the network will have access to the same critical information at the same time to maximize their situational awareness. To bring this goal about, the Navy plans to equip its people and its platforms with the tools, technologies and knowledge needed to fight and win in the 21st century.

The Navy’s next-generation destroyer, the DD-21, is being designed from the very beginning with the human—computer relationship in mind. There is the opportunity for this land-attack destroyer to revolutionize many aspects of going to sea. Technologies that can be available for the DD-21 include:

- Electric Drive
- Integrated Power Systems
- Extended Range Guided Munitions to support the Marine Corps
- Multifunctional radar tailored for the littoral areas

- Armed helicopters and unmanned aerial vehicles
- Organic mine-avoidance systems to detect and disarm undersea mines
- An unprecedented degree of stealth technology for ships, and
- A fully distributed total ship computing architecture

Many of these advances are enabled through computers and computer technologies.

The DD-21 will also be highly automated. The degree of automation on the DD-21 means the ship will be operated by crew of 95 sailors instead of hundreds. A smaller crew will reduce operating costs and put fewer men and women in harm's way; but, there is a trade-off. Yes, the crew will be technically and tactically proficient, have a higher degree of computer literacy and be skilled in all disciplines of surface warfare. But, each crewmember will direct more tasks and oversee a wider range of ship systems. We must ensure that the computer and information systems aboard this ship serve our sailors; not frustrate, confuse or intimidate them, and certainly, not fail them.

Fewer operators controlling complex systems mean an increase in the decision-making demands on those operators, particularly in crisis situations. Therefore, we must take full advantage of human perceptual and cognitive capabilities. Computer systems must also allow integration of information from multiple sources.

In the past, technical systems often were developed with little regard for the humans who would operate and maintain the systems. The Naval Forces of the 21st century cannot afford to do that. It would leave us technologically vulnerable and have a significant impact on our ability to recruit, train and retain quality people in a very competitive market. The desire to save costs and take advantage of the latest automation and information technologies means we must rethink our approach to the way our warfighters work, live and fight in tomorrow's world.

At ONR, we are supporting a number of system-interaction technologies. They are intended to:

- Relieve operators from monotonous tasks such as monitoring radar screens, which leave them unfocused and inattentive
- Focus operators attention on pertinent displays and information
- Reduce the need for operators to remember how to operate systems

The DD-21 program will improve the way the Navy does its business. It will take full advantage of both the Navy's scientific community and private industry. This streamlined approach will maximize our innovation and design flexibility and lower costs through the use of commercial off the shelf products and open-systems architectures. It will also allow the Navy-industry partnership to treat the human operator as an integral part of the design solution, which is essential to our success.

So, in the development of the DD-21; our partnership, interaction or dependence on computers will provide us with the ability to work smarter, have fewer people doing the all the jobs and save a considerable amount of resources in the process.

One question is, how will computers help us work smarter; I think the Decision Support Systems Future Naval Capability provides an example of that. Two cornerstones of the concept of Network Centric Warfare are embodied in our Future Naval Capabilities, Information Distribution, which is concerned primarily with connectivity issues, and Decision Support Systems. I'd like to focus on Decision Support Systems.

The overall goal of the Decision Support Systems FNC is to enable naval knowledge superiority. To do that we must support the warfighter through:

- Rapid accurate and common situational understanding in command and combat systems
- Increased speed of command...getting inside the enemy's cycle of decision and execution
- Capability of self-synchronization, and
- Provide dynamic and distributed planning and battle management

To achieve this we must provide our naval forces with a collectively shared tactical and operational picture and the ability for geographically distributed commanders to collaborate in decision making in a rapid and sustainable manner. Does industry need automated decision support? Yes, but the military requires **rapid, effective real-time decision-making**; industry does not. Industry can make corporate decisions now, or this afternoon or tomorrow or next week...warfighters do not have the luxury of "time".

The DSS FNC identified and prioritized enabling capabilities to achieve their objective. The two efforts that are funded in the FNC process are:

- Common Consistent Knowledge, and
- Distributed, Collaborative Planning and Rehearsal

Common Consistent Knowledge and Distributed Collaborative Planning and Rehearsal are critical enablers of Network Centric Warfare. They provide the technologies to develop and maintain the Common Picture and to plan and operate across all echelons consistent with the commander's intent. Let's look at those efforts and some of the technology that we will need to enable them.

Common Consistent Knowledge:

The goal is to enable geographically distributed forces to generate a timely common picture. Automation will be used to integrate data from many low-level sources into comprehensive information that decision-makers can use effectively. Key to this is the ability to visually present information that fosters instantaneous understanding...a picture is worth a thousand words. Capabilities that will be required include:

- The ability to exploit, manage and integrate complex information
- Development of a user-tailored picture...we cannot assume that a given picture is the best picture for everyone
- Situation-at-a-glance awareness
- Natural, intuitive HCI and

Cross-echelon commonality

Supporting technologies that must be developed and integrated to accomplish these efforts include:

- Intelligent software agents for searching, retrieval, filtering, data fusion and interpretation
- Data-mining for large heterogeneous databases
- Image exploitation and manipulation
- Language translation
- HCI: 3-D graphics, mobile/wearable devices, virtual / augmented reality, high resolution modular displays, speech and gesture recognition
- Human performance monitoring for workload management

As you can see, our partnership or interaction with, or our use of the computer will be very significant if we expect to provide the warfighter with the benefits of common tactical picture.

The second Enabling Capability is Distributed, Collaborative Planning and Rehearsal and it has a goal of moving knowledge and expertise, not people...significantly cutting time and cost. The intent of this effort is to have geographically distributed naval forces convey intent and plans that foster speed of command.

Capabilities that will be required include:

- Coordinated planning across all geographically distributed echelons and security enclaves
- Intuitive management of collaboration services
- Device and connectivity-independent collaboration
- Simulation support for rapid planning
- Ability to assess and rehearse plans

The supporting technologies that we must develop and integrate for this effort will include:

- Standards-based middle-ware for initiating, managing and reporting synchronous, asynchronous, heterogeneous, distributed collaborative work sessions
- Device interaction standardization / composable architectures
- Information tagging
- Virtual environments
- Audio interaction – speaker recognition, 3-D audio, etc
- Groupware for rapid planning during virtual conferences
- Active templates for plan development, simulation and assessment
- Fast, large-scale, high fidelity synthetic semi-autonomous forces in simulated littoral environments...includes fast-time dynamic what-if projections
- Cognitive models decision making, including opposing-force models
- Metrics for assessing plan quality, and
- Influence nets / executable models

Again, the strong need for the computer's ability to do what we cannot so that we benefit. And in this case, the very strong coupling of how we must interact with the products of the computer to reap those benefits.

In the DSS example, I think you can see the extent to which computers will enable the 21st century warfighter.

I'm not sure I've been able to define the human-computer partnership for you...or for myself. Is it a real partnership with benefits accrued by two consenting entities, so to speak, or is it a relationship between a tool and a master craftsman? Yes, we program the computer to do the things we want; but it exceeds our ability to do those things. It can gather data and provide us with knowledge from that data. Tools can't do that.

In closing, IBM Chairman, Thomas Watson was quoted as saying, "I think there is a world market for maybe five computers." We all know that prediction didn't pan-out very well! But, two other myths have dogged computers over the years: they take away jobs and they eliminate paper. The first myth has some truth to it. Yes, computers have generated new jobs in new industries; but jobs have been lost. But, is that bad? Banks could stay open all day and night and hire more people...or we can use ATM machines. Similarly, computers have been responsible for eliminating a number of repetitive, tedious chores...and that's good. People are too important to waste their abilities with repetitive and tedious jobs. We must enlist the capabilities of computers to improve the quality of life for our Naval Forces.

The second prediction that computers will eliminate paper has not proven to be as easy to find agreement. A recent ONR-supported survey found that the best medium for information manuals is still a book...not a floppy disk or a CD or a talking paper clip...a book is still the fastest and easiest way for an operator to lookup something.

So, it's a partnership or relationship that we must continue to develop and improve. One thing is certain, there is no going back. There is much we still have to work on and at times it seems as though it's a bit tenuous...either we're not quite willing to either 'trust' completely, or we're not willing to give-up old habits. How many of you still print-out email? It isn't email, or electronic mail, once you print it out...it's a letter or memo or whatever. And how many of you use paper copies for your briefing notes...or speeches.

Thank you!

A Rifle Range for the Mind

James A. Laswell (Col. USMC Ret.)

Senior Analyst GAMA Corporation



Combat Decision Range



A Rifle Range for the Mind

2 May 2000



What Skills Are We Developing?



- Acceptance of Role as Decisionmaker
- Decisiveness
- Communication skills
- Mission Analysis
- Situation recognition
- Acceptance of the ambiguity



How to Measure Success?

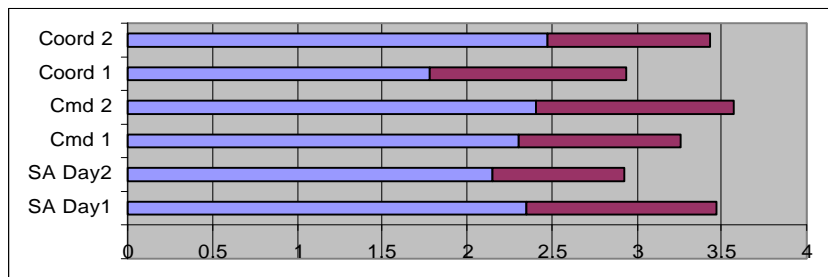

- Improved Scores -- Self Assessment
- Supervisor's Evaluation -- Performance!
- 1/5 "Actions on the Objective at CAX"



Situation Awareness

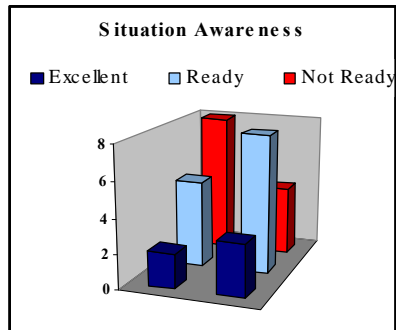

- Typical Situations
- Doctrinal Keys
- Mission Specifics
- Patterns
- TTPs
- Recognize and react!



Direction to Subordinates

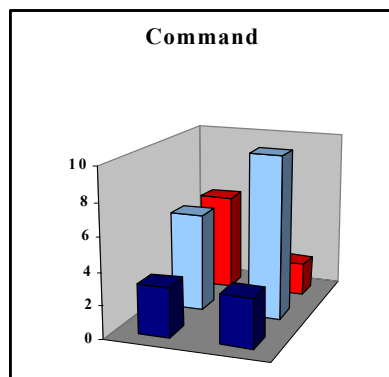

- Control
- Clear verbal orders
- Confidence
- Unit SOPs
- Self-confidence



External Coordination

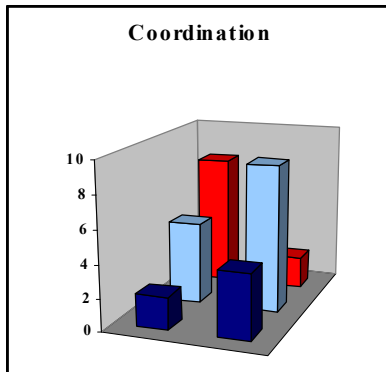

- Higher Echelons
- Lateral Echelons
- Comm Procedures
- Reporting
- Unit SOPs
- Self-confidence

Combat Decision Range Evaluations

(n= 47, E-3 thru E-5)

Average CDR use across all infantry regiments: 40 hours/month

Recommend CDR Marine-Corps-wide?



No

("Spend all the time in the field")

Improves Decisionmaking?



Strongly
(All)

Improves Tactics?

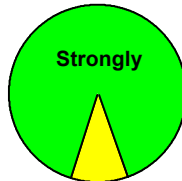

Somewhat

Improves Land Navigation?



Strongly

Somewhat

No



Who Else Improves?



- Small Unit Leaders
- Facilitators
- Unit Leaders:
 - Assignment screening tool
 - Training level assessment
 - SOP and TTP review



Key Factors for Success



For the Unit:

- **Focus on unit needs**
- Develop leaders
- Reinforce TTPs
- Improve comm skills
- Unit wide standard
- Garrison Tool
- Take it anywhere

For the Individual:

- Train as a unit
- Challenged/Interesting
- Relevant
- Carryover into unit SOPs
- Recognition (debrief)
- **“Horns of a Dilemma”**

The Present and Future Role of Information Security, Infrastructure Assurance Issues, and The FBI's National Infrastructure Protection Center

Presented May 2, 2000 by IOS Steve York

Disclaimer: This paper contains the opinions solely of its author and does not represent the views of the Federal Bureau of Investigation or the Department of Justice.

Introduction

More than a decade after the end of the Cold War, US national security policy-making elites and the American public, now find themselves inexorably allied together in the face of a new challenge to our much envied way of life. Indeed, it is a conundrum of our own creation. For while we breathed a collective sigh of relief as the specter of nuclear annihilation by the former Soviet Union quickly receded and we began to anticipate a well-deserved, peace dividend, the same engine of efficiency; namely, American business and its associated entrepreneurial spirit that drove the fatal stake into the heart of the central planning systems of Lenin-Stalinist communism, was unwittingly presenting us with a societal challenge perhaps as great as either the American Revolution or the Civil War were to our forefathers. By expeditiously “wiring” our intellectual and business centers of gravity during the late 80s and throughout 90s, we were also surreptitiously sowing the seeds of widespread, digitally based vulnerabilities in the more physical components of our nation’s infrastructures.

Arguably, we must come to grips with at least three issues. First, how we will defend the critical infrastructures that undergird our Nation against those who would seek to thwart the attainment of our foreign policy goals by possibly placing key components of those infrastructures at risk? Second, how will we promote a healthy but necessary tension between the domestic role of government to serve or protect its citizens and the corresponding responsibility of the private sector to create or maintain an efficient marketplace of goods and services; when in either case the aforementioned governmental services and protection roles or marketplace maintenance functions are increasingly derived from information systems? Thirdly, how will we learn to live with the dizzying pace of technology on our lives which is becoming daily more evident. I submit that grappling with these three issues collectively will prove to be

no less difficult than fashioning either the will to drive what was then the most powerful army from our shores or, some 80 years later, to keep that same young Nation unified.

I believe that any reasoned, national debate on how to deal with the other, darker side of the information revolution would yield at least three courses of action. First, the role of secure and reliable information and information systems will grow in importance and it will prove to be a multi-level, never-ending task. Second, an awareness of infrastructure assurance issues will demand the creation of both a science-based and public policy communities that will position the Nation, at all levels of government, to better deal with the vulnerabilities accompanying the benefits of a “wired” world. And finally, multi-disciplinarian organizations like the NIPC will emerge as that bridge between domestic and overseas national security issues.

Information Security - -What is It? : Today and Tomorrow

My own definition of information security, or at least the one that we at the NIPC are attempting to impart to the agents today who attend training on the FBI’s Key Asset Initiative and InfraGard program, as well as those receiving more technical instruction on widely-used information systems operations and security by the FBI Academy at Quantico, Virginia, has three fundamental elements.

First, is a fairly high-level, operational understanding of how a information systems operates when properly configured and therefore an understanding of the limitations of the security features built into the system by its designer. Secondly, we approach information security as a state of mind. By that I mean, what are the internal processes the system administrator attempts to impose on system users with the concurrence of the owner of that information system (password utilization and other standard housekeeping protocols) as well as assessing the maturity of the risk assessment or management plan and any accompanying business recovery/crisis management plan. As we have all learned from the Y2K experience, implementing security features, which may or may not slow down business processes in the long run, are worth their weight in gold. Further, possessing a business recovery plan with which all system users are familiar enables the organization to exude confidence and more than likely ride out a “bad hair day” with respect to information systems nonavailability. The final element is an

organization-wide appreciation for the integrity and reliability of the data itself. If you want the computing power of these machines to aid you in your decision making process, then numbers or “facts” that go into the equation must be inviolate. Based on the growing number of reports now appearing in the mainstream media, testosterone-powered teenagers, disgruntled employees, hacktivists, criminals, terrorists, and nation-states can all anticipate the key features revealed to the public likely to accompany any real impact brought about by a successful denial or disruption of information-dependent infrastructures such as utilities, transportation, or financial institutions.

Even more insidious, and thankfully correspondingly more difficult to set into motion, is the deliberate corruption or manipulation of data in carefully conceived ways so as to possibly manage the perception of decision makers wrestling with complex, fast-moving events. That America should become the targets of such skillful strategies ought not to surprise us. We are often accused of attempting to management the perception of the designated rogue nation decision-makers, why shouldn't someone attempt to turn the tables on us? As a brief aside, a former member of the media who is a frequent speaker at the National Defense University on the topic of information operations and is far more familiar with this issue than I, alleges that the FBI still has on its books a World War II-era mission of being that federal department or agency responsible for countering propaganda aimed at the American public from within our shores. If true, what are the implications today for the Bureau of this long-forgotten mission?

In a more relevant context, I assume that many at this conference are all too familiar with the implications of the work by the two mid-grade officers attending the PRC Army War College made recently available over the Internet. Moreover, and with full acknowledgment of how cynical this observation may sound; do we not live in the nation that gave the world the “content merchants and spin doctors” of Madison Avenue fame? Elements of our own business world arguably practice a form of perception management on the American consuming public daily. Accordingly, I doubt that we any longer hold a monopoly on actions that can be taken to breach the integrity and reliability of data reposing within presumptive secure information systems.

How many of these three elements - - knowledge of information systems operation, security seen as a state of mind, and an appreciation for data integrity and reliability - - will carry over into any

future discussion of information security? I'll play it safe and say all three will exist in some form or another. But from what I can learn about information systems security, the greatest strides will likely be made in incorporating security features into product design and not adding them on as an afterthought. My source for this educated guess is having been afforded the opportunity to attend two recent gatherings of the Association of Computing Machines or ACM. This is the oldest association to have focused on computer operations and security issues. The sense of the majority of the members of this association appears to be that enhanced built-in security features is what US business will demand and be willing to settle for nothing less. The challenge will be, as I understand it, can industry in fact deliver the desired product and at an affordable price?

Further, I suspect that employees will be steadily encouraged, even compelled upon pain of job loss, to comply with increasingly strict, computer user security policies in much the same way that other actions once viewed as intrusive but are now seen as mundane. I am referring to seat belts, auto theft prevention devices, and annual safety inspections, three initiatives that are now a fact of life when they weren't a decade or so ago. Finally, the requirement for data integrity and reliability will remain immutable, specifically if the viability of the "new economy" rests on the efficiencies that e-commerce and business-to-business technologies are just now beginning to deliver.

Infrastructure Assurance - - not Protection - - is "the issue"

Presidential Decision Directive 63 requires the federal government, regardless of who sits in the Oval Office, to have in place an initial operating capability, or IOC by May 2003 that will enable the continued operation of "minimum essential" components within the eight identified infrastructure sectors. The PDD charges the entire executive branch of the federal government to meet this objective and asks the private sector to assist. The infrastructure sectors include just about everything that daily effects our lives except the production of food, means to relax or conduct some sort of recreational activity, and the capacity to practice our religious inclinations, if we chose to do so. The President's Commission on Critical Infrastructure Protection intentionally declined to include these three activities or pursuits as a part of its issues, findings,

and recommendations and so, those of us at the Center do not focus on any matter related to these three issues.

The Commission was also hamstrung by the lack of time to fully explore the concept of risk assessment and management strategies as they might pertain to infrastructure operations. This was a crucial shortcoming because exploration of risk assessment and management underlies how the American private sector views business operations in general and is also how an authority, no less accomplished than the National Security Agency, views the science of protecting sensitive, high priority information systems from compromise. Both business and information security organizations accept that they cannot “zero out” risk, since the nature of the environment in which they operate is filled with unknowables and complexities associated with tightly coupled systems (i) (Perrow 1999) that can yield unintended consequences such as lost business opportunities or compromised information.

This world is unlike that of the traditional national security community which calculates threats more than focusing on risk levels, and seeks to protect or defend against all possibilities because the viability of the state may be at issue rather than guaranteeing or assurance certain core business operations while letting other business lines expire or be taken over by more efficient means of production. Both worlds want to survive, but can measure success by different yardsticks. One prefers to defend by eliminating risk through the application of overwhelming force while the other is often content to prevail by retaining market share while always remaining open to new markets pursuits, should the risk prove to be measurable and acceptable. Hence, until we know a lot more about how the nation’s infrastructures which is generally owned and operated by businessmen are truly interdependent, we have a problem that is best addressed by thinking in terms of assurance and risk management.

However, I do not work at the National Infrastructure Assurance Center. While I have no way of knowing, I suspect the term “Protection” was likely carefully added to the Center’s title to instill confidence regarding a security matter we’re only beginning to understand. It probably also reflects the fact that some level of protection may be possible because we do possess certain technological tools which we prefer not to discuss openly that could act as a deterrent to an

imprudent criminal organization, select terrorist groups, and more than likely, many if not all modern nation-states who view us as “friendly competitors” or likely obstacles their own ambitions. For now, I can live with the title the Center bears as long as we as a nation do not read too much into exactly what the term “Protection” really means. We have much work ahead of us in order to avoid being lulled into a false sense of security.

The FBI’s National Infrastructure Protection Center (NIPC)

When the President issued PDD 63, very few departments or agencies had thought ahead to preposition either programmatic resources or personnel to begin work on infrastructure assurance issues. For most of the federal government, the actions required by PDD 63 fell on them much like an unfunded mandate. Even today, many budgets are woefully underfunded for the task at hand and offices within these department and agencies remain staffed at skeletal levels. The Department of Defense (to include the National Security Agency), the CIA, and the FBI were the only federal entities with a gameplan and money already in hand when the PDD 63 clock started ticking its countdown to the aforementioned May 2003 IOC target date. Unfortunately, a little more than a year after the NIPC was carved out of FBI Headquarters, preparation for Y2K or the Millennium Rollover began, an event which temporarily displaced many initiatives within the NIPC as it did to most information technology-related activities across the US private and public sectors.

The NIPC was and is still envisioned by the Attorney General and the FBI to become a truly joint or interagency initiative, whose likes have not been seen before at the FBI. Generally speaking, interagency centers have a spotty track record inside the Beltway. Perhaps the most successful is the Counterterrorism Center at the CIA while lesser success stories are embodied in the Nonproliferation Center, also at the CIA and the National Defense Preparedness Office, at the Bureau, a recent outgrowth of the various manifestations of the Nunn-Lugar Act. None of the above have truly attempted to make management a shared function, by which I mean that either the head or deputy of each unit within the NIPC is an FBI supervisory special agent or senior support specialist while the corresponding billet within each unit is filled by a detailee from another government agency.

Provisions exist for staffing by representatives of the private sector or experts from the varying infrastructure sectors but to date these vacancies remain as final details are being resolved that did serve as a bar to civilian access to law enforcement sensitive material that resides in the Center. Such private sector expertise is critically needed for its engineering analytic capabilities and pinpoint contacts within industry which can then in turn be married up with ongoing intelligence analytic capabilities which the Bureau, as a member of the intelligence community, can adequately provide on its own. In fact, a recent reorganization within the FBI is intended to fuse all intelligence activities within the Bureau, breaking down wherever possible those stovepipes that bar speedy and efficient processing of all source data. The Bureau has realized that in the age where crime can now move at the speed of light, different ways of doing business must be pursued.

The organizational chart provided herein (Figure 1) depicts the investigatory, analytical, and outreach branches of the NIPC. A third of the billets are for other government agency detailees. A second third of the positions, though now FBI employees like myself, were hired as professional support staff who bring a distinctly, non-law enforcement but nonetheless experienced national security perspective to the emerging problem of infrastructure assurance. The final third of the personnel working within the NIPC is comprised of seasoned FBI special agents. The bottomline here is that two thirds of the NIPC complement brings a fresh, “why not try this” approach to a thorny problem that has clear law enforcement implications but also requires innovative thought in the absence of hard data to the contrary.

Further innovations for the FBI within the NIPC lie in four areas (Figure 2). They are as follows: a fully interactive website; a law enforcement sector services assurance plan; InfraGard, a virtual private network focused on information security issues provided to infrastructure owners and operators by the Bureau; and the only truly bottoms-up, approach to mapping all of the Nation’s “minimum essential infrastructure” as called for by PDD 63, known within the Bureau as the Key Asset Initiative.

Of particular interest to this conference is the fact that by the end of 2000, the Key Asset Initiative will have fielded the Bureau’s first geographic information system at all 56 division

offices (Figure 3). When paired with the already deployed Key Asset Initiative software, special agents will be able to gain local and some national-level “situational awareness” regarding the identification and characterization of key assets with which they are required to develop long-standing relationships. They can then begin to implement the training they’ve received on applying basic risk assessment and management techniques in concert with local infrastructure owners and operators. Crisis response plans can be jointly developed by the agent and key asset management that boosts the confidence of all concerned regarding the key asset’s ability to quickly recover from a cyber-based interruption in its key business operations (Figure 4). Finally, law enforcement can begin to move from a traditionally reactive role to a more proactive posture based on a greater situational awareness of the complex web of infrastructure interdependencies found in the community the agent serves and indeed lives with his family.

Summary

The Bureau, through the NIPC, has taken aggressive action in order to come to grips with the predominant national security issue certain to confront our Nation in the 21st century. Information-based technology and the security issues that arise from an absence of data integrity and reliability are the source of this threat to our way of life and standard of living. Oddly enough, information-based technology can also provide us with a way to manage the risks associated with this threat. It is a double-edged sword that those interested in pushing the exploration of national security, decision-support initiatives must wield skillfully and without hesitation.

References

Perrow, Charles (1999); *Complex Systems*; Yale Press

NIPC Organization

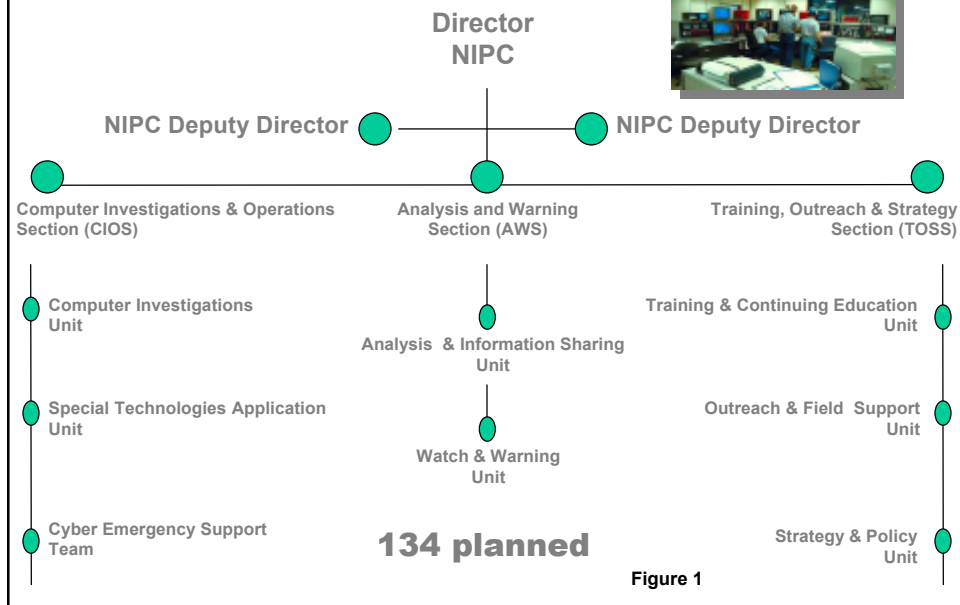

FBI and NIPC Initiatives

- **NIPC Website**
- **Law Enforcement sector (PDD 63)**
- **InfraGard**
- **“key asset” program for 21st century**

Figure 2

Key Asset Initiative Where Are We Going?

Locate Key Assets

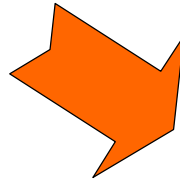
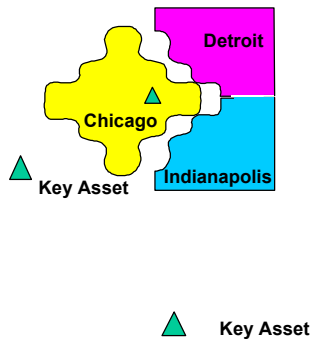

Begin Building
National Picture

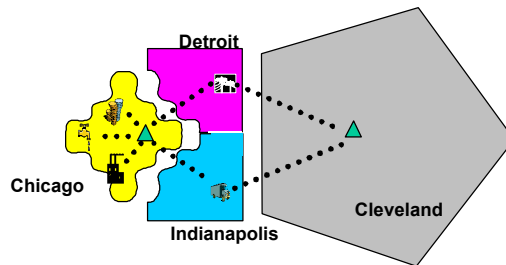

Figure 3

New KAI-related Training for Field Agents

After a 1st order designation of "what's critical/what's not"

Internal Disaster Recovery Strategies for Businesses

- Understanding "risk models"
 - model attributes
 - risk categories
 - risk metrics
 - data gathering
 - model results interpretation

Goal: See the problem thru the eyes of a businessman

Theory & Practical Application Course

- General network vulnerability theory
- General network susceptibility to specific threats
 - direct or indirect system effects
- "rough" quantification of disruption's impact on respective stakeholders
 - dependency issues within/across infrastructure sectors
- Recovery option development theory

Goal: See the problem thru the eyes of attacker/defender

Infrastructure Interactive Exercise

- Enable agents to conduct 4 hour simulation

Goal: Explore issues and builds trust

Figure 4

The Marine Corps Warfighting Laboratory: Experiments in Progress

John Allison (Lt.Col. USMC Ret.)

Director, Program Integration

Marine Corps Warfighting Laboratory



Experiments in Progress

2 May, 2000

Mr. John Allison
Director
Program Integration



MCWL Mission

- Serve as the focal point for refinements of future warfighting capabilities
- Develop tactics, techniques, and procedures to enhance future warfighting capabilities
- Evaluate advanced technologies and transition those that create or enhance future warfighting capabilities into the Marine Corps Combat Development System



Experimentation Process



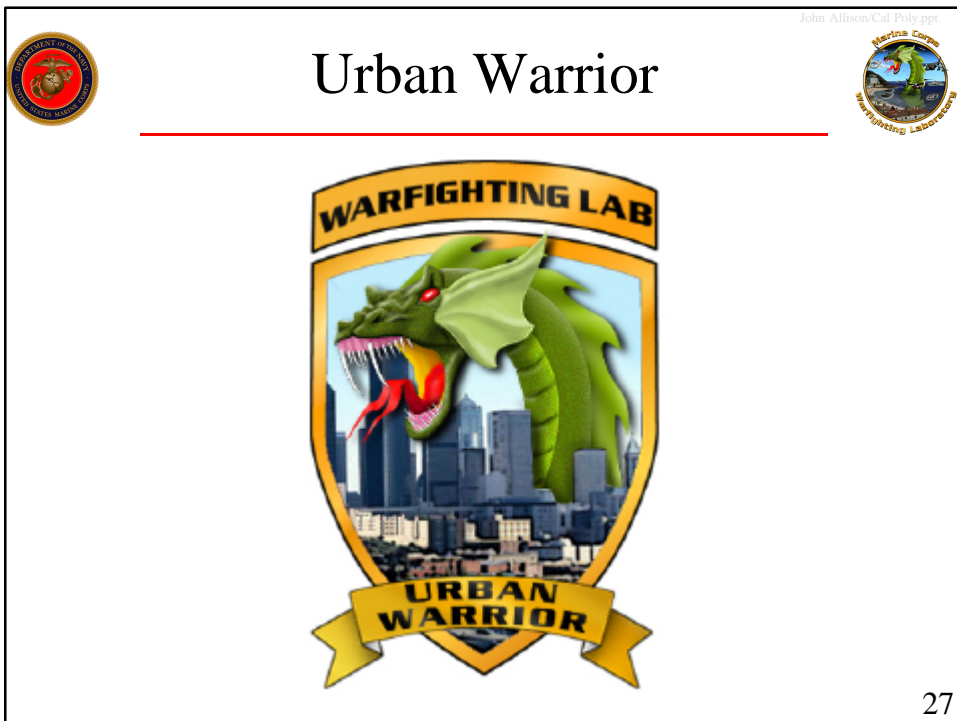
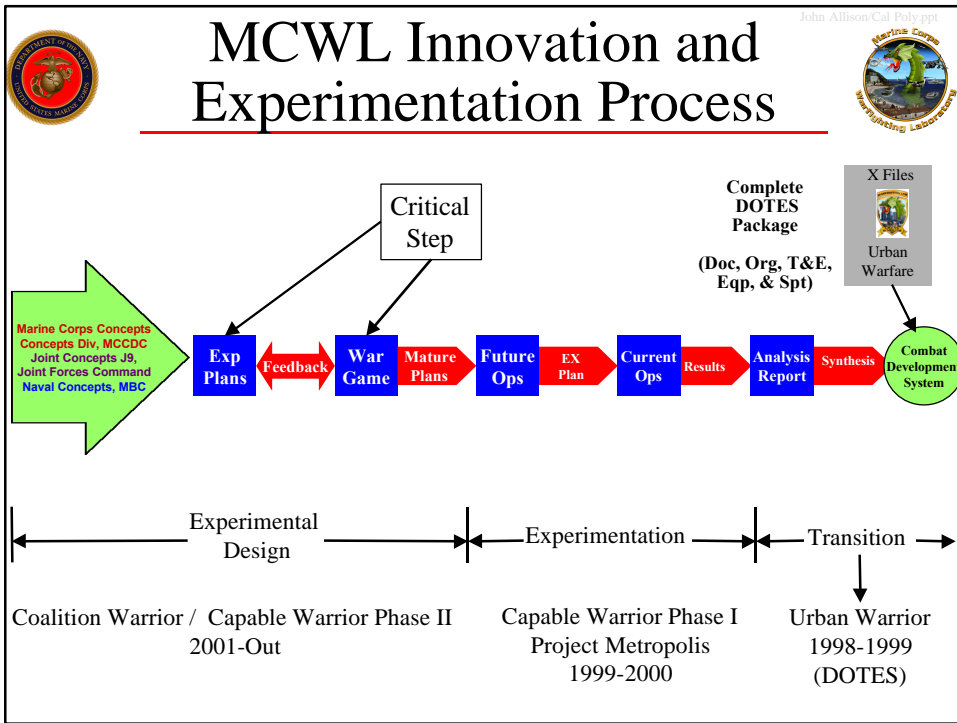



Urban Warrior Products

Solving Today's Problems

John Allison/Cal Poly.ppt



Combat Decision Range (CDR)

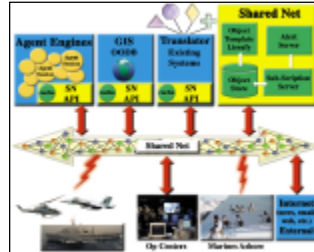

IMMACCS

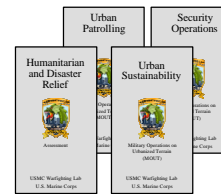

X-Files: Lessons Learned



Night Vision Lab



Yodaville (Urban CAS Range)



Urban Warrior Products

Solving Today's Problems

John Allison/Cal Poly.ppt



Portable ROWPU



Intra Squad Radio



Urban Camouflage Uniform



Dragon Drone



VIPER PITS



Ground Observation Special Support Intel Prgm (GOSSIP)



Interim Fast Attack Vehicle (IFAV)



Urban Warrior Products Solving Today's Problems

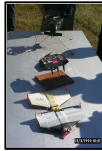

"Dragon Eye"
Platoon
Commander's UAV



Dragon Warrior



Hand Held GPS



Multi-Lingual
Interview
System (MIS)



Night Scope

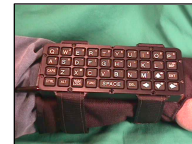

EUT Touch Pad



Combat Decision Range (CDR)



- Extremely successful training means
- Universally hailed by commanders and trainees as a desirable product
- 27% improvement in readiness

- » Train NCO's in Combat Decision Making and Leadership
- » For Use by Every Infantry Regiment in the Marine Corps
- » Operational March 1999
- » Computer Based Training System
- » Uses 12 Major Scenarios from peace keeping to combat
- » More decisions in one scenario than a week in the field



Aviation LTA May – June 1999



Yodaville

- **Capability:**
 - Fully instrumented facility
 - Coverage down to 3,000ft AGL
 - Expanding coverage to deck in FY00
 - “No Drop” bomb scoring
 - 184 scorable aim points
 - Aim points monitored by video cameras
- **Description:**
 - Urban aviation range in Yuma, AZ
 - Conceived by MAWTS-1
 - Funded by MCWL
 - Assess effectiveness of CAS TTP’s
 - 178 buildings, 22 streets, 31 vehicles, and 120 personnel targets
 - 5 hardened FAC OP’s around complex



Project Metropolis

- **Objectives:**
 - Develop a comprehensive urban warfighting Program of Instruction (POI)
 - Develop TT&Ps to enable Marines to fight and win in MOUT with reduced casualties
 - Recommend improvements to existing and future MOUT training facilities
 - Evaluate selected enabling technologies that enhance small unit combined arms capabilities



Jun'99 - Jun'00



Project Tun Tavern

Technology Support for the Recruiting-Sub-Station

John Allison/Cal Poly.ppt



- Focus is on providing assistance to the Marine Recruiter and the RSS NCOIC by providing advanced information technologies and software
- The experiment will assess if these technologies can speed up contract time, reduce administrative time, access higher quality applicants, and produce a better quality of life for the Recruiter



Project Atlanta

John Allison/Cal Poly.ppt



- New TTPs and technologies dealing with chemical and biological incidents in homeland defense and foreign conflicts
- The experiments will focus on:
 - Marine Corps emergency managers
 - Interoperability with civilians and access to technology
- Southern Response Experiment
 - A partnership between MCWL and Georgia Tech Research Institute
 - Focus on advanced TTPs for first responders and emergency managers
 - Demonstrate countering potential chemical / biological threats to the Southeastern United States





Capable Warrior



Capable Warrior Hypothesis

- If we can apply a combination of innovative concepts and improvements in technology to four key areas:
 - Command and Control
 - Sea based fires
 - Sea based logistics
 - Mine Counter Measures
- Then, we can begin to realize the vision of Operational Maneuver from the Sea as the naval contribution to the JV 2010 Concept of Dominant





LOE 6

Assess an experimental expeditionary C4ISR system that enables a MAGTF to conduct Naval combined arms live fire

- RSTA Phase
 - Integrate sensors into IMMACCS to support rapid operations
- XCAX Phase
 - Conduct collaborative planning and execution in combined arms operations using Common Tactical Picture (CTP)



LTA
24-28 Jan

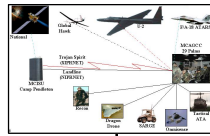

RSTA Phase
2-3 Mar

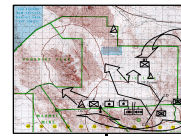

XCAX Phase
15-16 Mar



Advanced Close Air Support System Limited Technical Assessment



Global Positioning System (GPS)

FAC Equipment



Planning Tools

Digital Maps/Elevation

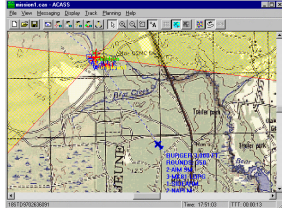

Tactical Overlays
Real Time Aircraft Tracking

31 May-8 June 2000
MCAS Yuma, AZ

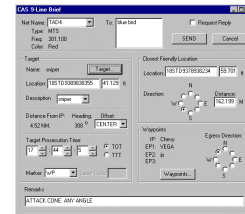



Millennium Dragon

September 2000

John Allison/Cal Poly.ppt



Mission

MCWL will conduct an experiment of STOM operations with a C4I system that integrates national assets, supports integration of long range fires with long range maneuver, and improves decisionmaking in order to develop STOM Force TTTPs for a MAGTF in a joint environment.



Millennium Dragon

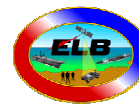

Objectives

John Allison/Cal Poly.ppt







- C2 of the LPTF maneuver forces in STOM
- Fuse data to produce a real-time CTP
 - Intelligence
 - Maneuver
 - Fires
 - C2
- Experiment with task organization and table of equipment in expeditionary operations

John Allison/Cal Poly.ppt



Kernel Blitz (X) Objectives

June 2001

- Integrated Naval Service C4ISR architecture:
 - Command relationships / Task organization
 - Staff functions (Integrated)
- Sensor, fire control and information networks to form a C4ISR architecture
- Refine TTTPs for OMFTS/STOM force

John Allison/Cal Poly.ppt

Experimentation Focus

<u>Capable Warrior</u>	<u>Millennium Warrior (02)</u>	<u>Coalition Warrior</u>	<u>Millennium Warrior (04)</u>
<ul style="list-style-type: none"> • Expeditionary Ops <ul style="list-style-type: none"> • Littorals • TTPs for STOM force • Navy coordination • Millennium Dragon 	<ul style="list-style-type: none"> • Joint interoperability • Command relationships • MEB level forces 	<ul style="list-style-type: none"> • Joint / Combined interoperability • Task organization • Command relationships • MEB level forces 	<ul style="list-style-type: none"> • Joint interoperability • First major joint integrating experiment
2001	2002	2003	2004

35



WWW.MCWL.QUANTICO.USMC.MIL

John Allison Col Poly 201



| [Click to Enter](#) | [Notice To Users](#) | [Contact Us](#) |

MCWL Link to our Operating Forces

(Intentionally blank)

ELB ACTD:

Speeding Technology to the Warfighter

Ray Cole (Col. USMC Ret.)

Demonstration/Program Manager

Extending the Littoral Battlespace ACTD, ONR



DIRECTION

OBJECTIVE:

“...to Demonstrate an Enhanced Integrated C2/ Fires and Targeting Capability to Enable Rapid Employment / Maneuver / Fire Support From the Sea of Dispersed Units Operating in an Extended Littoral Battlespace in the Following Areas:

- Flattened, Rapid, Webbed Distributed C2 Processes;
- Common Situational Understanding;
- Fully Coupled Decision / Planning / Execution Systems (Sea/Land) on Shared Battlespace Network;
- Intelligent Networks;
- Improved Combined Fires Response Time.”

APPROACH:

“...multi-Phased Demonstration Which Will Leverage Other DoD ACTD Efforts and Navy/Marine Corps Unique Initiatives to Develop New Capabilities. Both Non-Developmental Items (NDI) and Commercial Off-The-Shelf (COTS) Enabling Technologies Will Be Utilized to the Maximum Extent Practical.”

Two Major System Demonstrations (MSDs)

- MSD I - 2nd Quarter FY99
- MSD II- 3rd Quarter FY01

ELB ACTD Implementation Directive 31 Jan 1997

SERVICE CO-SPONSORS



OPERATIONAL SPONSOR



EXECUTING AGENTS



ELB SCOPE

ELB as an Umbrella ACTD will:

- ⚡ Provide the means to integrate technologies focused on the distributed force needs in the littorals
- ⚡ Demonstrate this capability with operational forces to identify operational utility and remaining technology gaps

“Rapid Technology Insertion to Advance WARFIGHTING in the Littorals”

ELB ACTD

ELB ACTD ARCHITECTURE

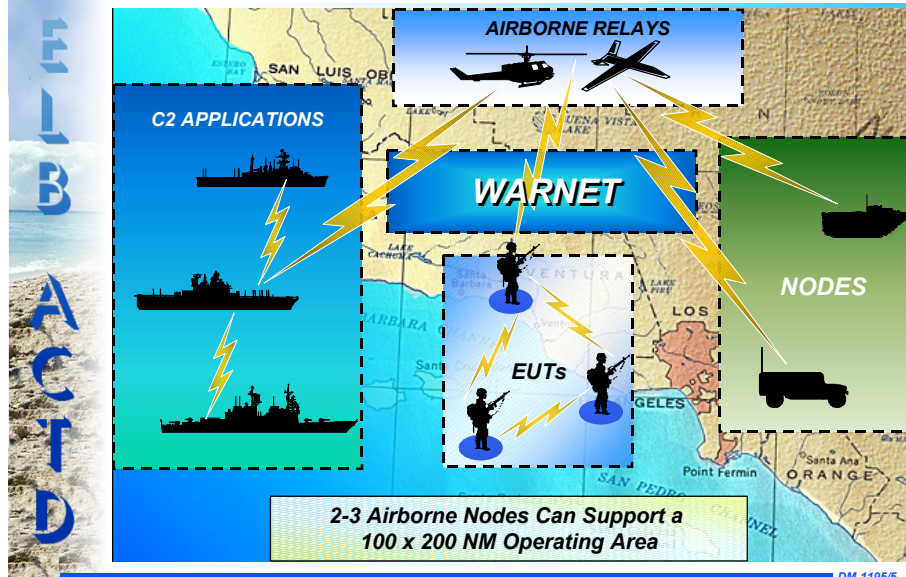

DECISION-MAKING PARADIGM



COMBAT DECISION-MAKING PROCESS

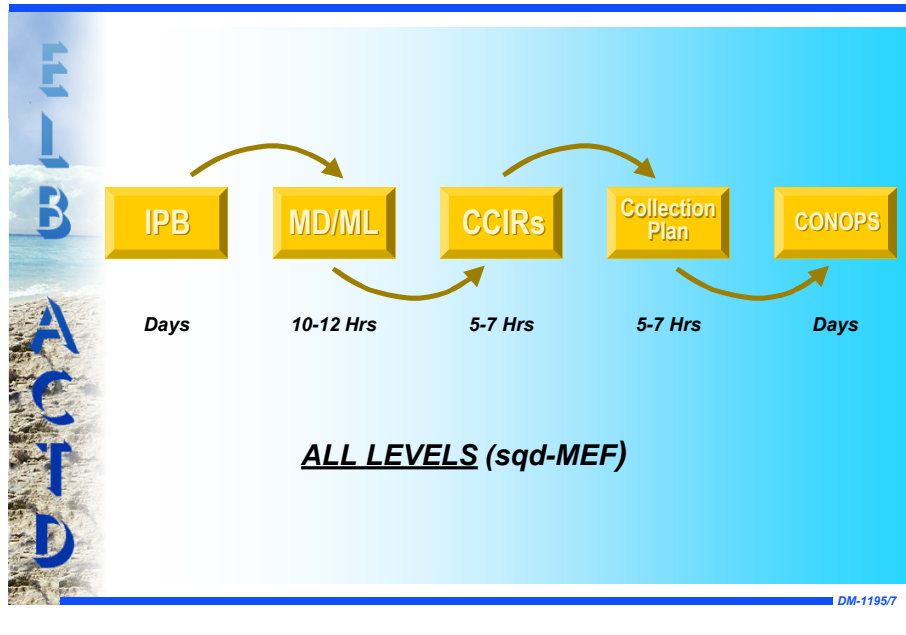

SOME THOUGHTS

- ⚡ A definite process
- ⚡ Labor / time intensive
- ⚡ Can't keep pace
- ⚡ Technology can help
- ⚡ Technology can hurt

Need fused intelligence not just data!

ELB ACTD BENEFITS

Decreased Reliance on SATCOM & Ground-based Relays

Increased Situational Awareness

Decreased Fratricide

Arrives w/ Commander in AOA

Increased Access to Fires

ENHANCED LETHALITY & SURVIVABILITY

C2 On-The Move

C2 TO THE Small Unit

MSD I ASSESSMENT

- ⚡ ELB network must be: *more robust, scalable, more easily managed and secure*
- ⚡ Lessons learned: how to organize, manage outside support, take care of Marines and Sailors
- ⚡ Enhanced access to fire support
- ⚡ Reduced reliance on SATCOM and ground-based relays
- ⚡ Reduced fratricide
- ⚡ Enhanced ship-to-ship collaboration

CAMPAIGN PLAN

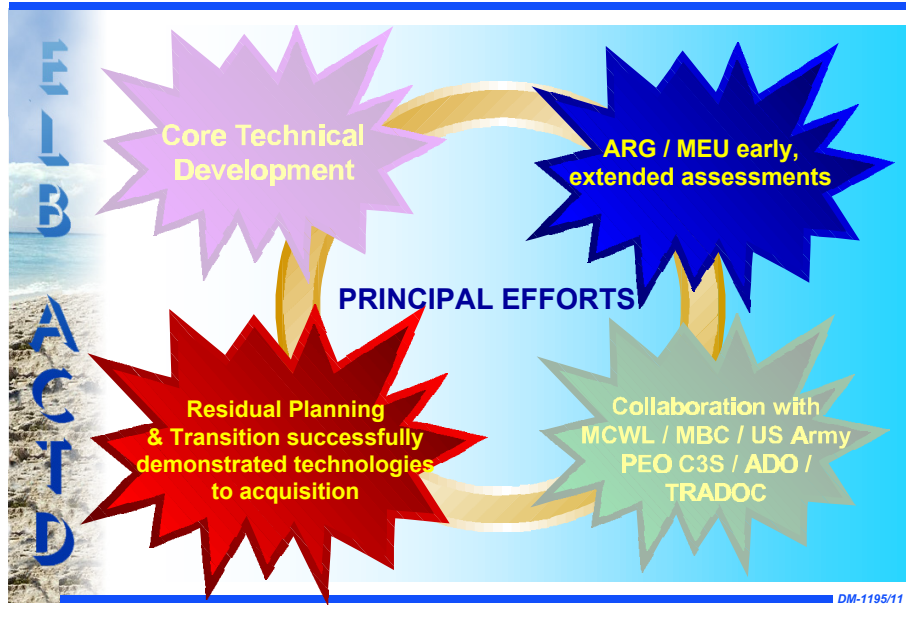

TARAWA ARG / 13TH MEU

Significant test events

• In port	14 Feb		Complete
• At sea	21-31 Mar	FLEET WEEK	Complete
	10-21 Apr	COMPTUEX	Complete
	19-23 May	FLEETEX	

WARNET successfully supported VTC, chat, file transfers, whiteboard collaboration

- Used regularly to conduct CPR5 staff meetings, Ops / Intel briefings, operations officer coordination / planning efforts
- Reliable method to conduct inter-ship coordination, distribute relevant information files and messages

Secure 50nm OTH ship-to-shore link demonstrated between TARAWA / Duluth to HMMWV via UH-1 Airborne relay

Novel employment of WARNET capability

- Whiteboard capability supported CIWS repair
- Whiteboard capability used to familiarize medical staff on surgical procedures

DM-1195/12

NEW PLANNING TOOLS

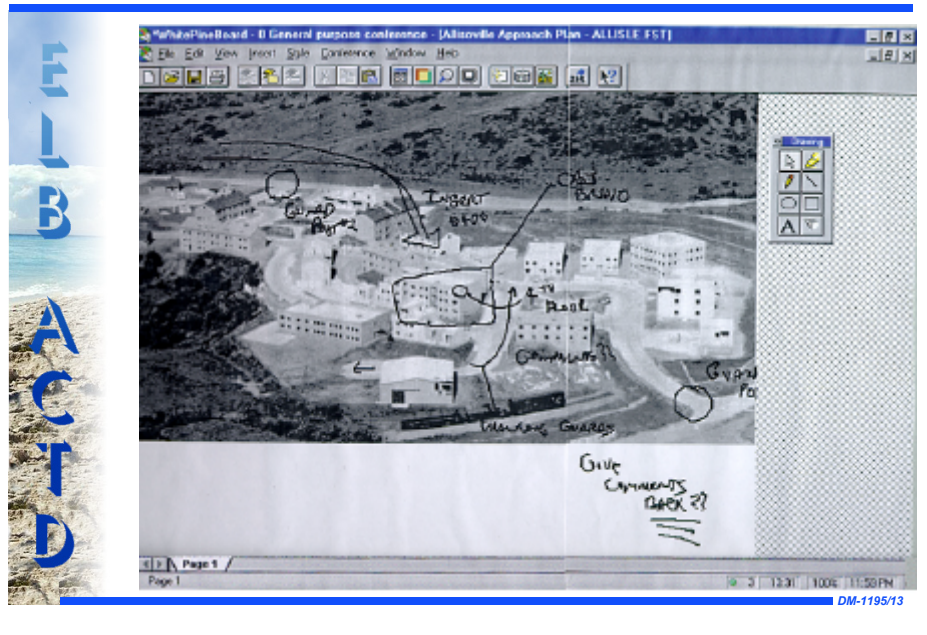

WHAT TARAWA ARG /13TH MEU DEMONSTRATED

- ⚡ Initial Results Positive - Network receiving extensive use
- ⚡ Extended ranges with helo relay package begins 29 March
- ⚡ Some EMI Interference by TAS (Long Range Mode) noted

ARG / MEU IN-PORT / AT SEA TEST RESULTS



- ⚡ Partial configuration installation - Ship-to-ship (1 UH-1, 1 HMMWV, VRC-99A only)
- ⚡ Demonstrated connectivity at 10Mbps “burst rate,” sustained throughput under review
- ⚡ EMI noted with Target Acquisition System
- ⚡ Blind spots / geometries still under review
- ⚡ Helicopter VRC-99A relay successful over-the -horizon, testing continues
- ⚡ Star SaFire Thermal Imaging System testing underway, ground tests near full motion video with new CODEC
- ⚡ VRC-99A requires periodic reset during continuous Ops

DM-1195/15

TRANSITION AND RESIDUAL PROCESS

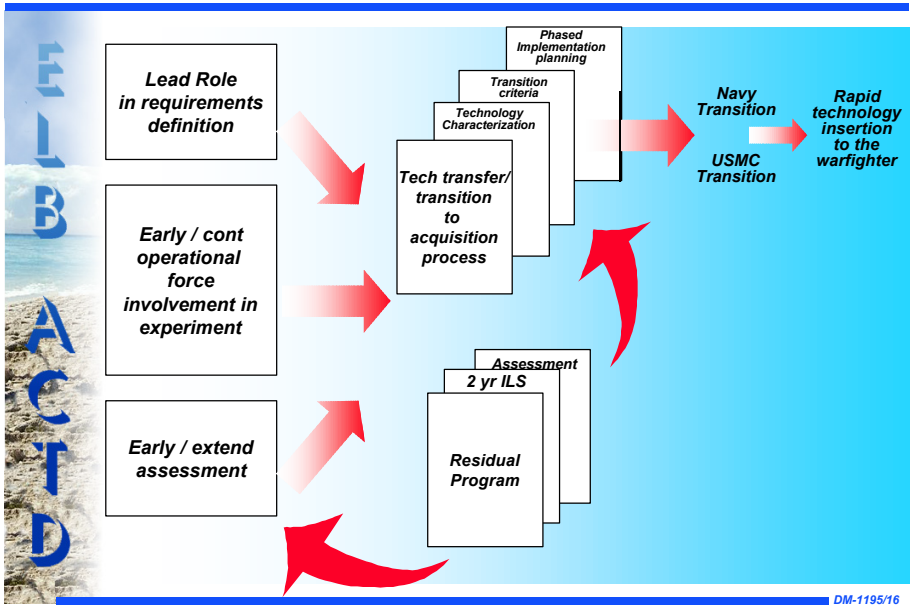

RESIDUAL PROGRAM



- ⚡ TARAWA ARG / 13th MEU
 - Ship-to-ship suite (AUG '00 deploy)
 - Limited ship-to-shore suite
 - Use of ground node
 - C2 / collaborative tools
 - Airborne relay
 - EUTs
- ⚡ BHR ARG (MSD II Ships)
 - Ship-to-ship suite (BHR ARG)(Jun 01)
 - Ship-to-shore suite (Feb '02)
 - C2 / collaborative tools
 - Handheld

ELB ACTD Technology Suites
 WARNET / ECOC / CCVs / Airborne Relay / EUTs

DM-1195/17

TRANSITION / TECHNOLOGY INSERTION



Primary Targets

- | | |
|--------------------------------------|---|
| ⚡ Unit Operations Center (UOC) | ⚡ AAV (DRPM) |
| ⚡ Joint Tactical Radio System (JTRS) | ⚡ ADNS (Advanced Digital Networking System) (PMW - 158) |
| ⚡ VTUAV | ⚡ TCDL |
| | ⚡ DWTS (Digital Wideband Transmission System) |

Potential Targets

- | | |
|----------|--|
| AAV C7A1 | Joint Maritime Comm System / Global Command & Control System |
| LAV | METOC |
| DD21 | LPD 17 |
| CAC2S | AUSWC |
| CEC | Advanced Deployable System (ADS) |
| MV-22 | |
| JCC(X) | |

DM-1195/18

STANDARDS AND REQUIREMENTS

ELB
ACTD

- ⚡ TEMPALT / SHIPALT
- ⚡ Security accreditation (interface afloat LANs)
- ⚡ ISNS / ADNS certification
- ⚡ EMI characterization / testing

DM-1195/19

ROAD AHEAD

ELB
ACTD

- ⚡ FST-1
 - 19-30 June '00
 - SSC Lab SD, Camp Pendleton, NAS EI Centro
 - ELB Contractors with SPMAGTF / I MEF observers
 - Focus: Comms / Networking
- ⚡ Millennium Dragon (FST-2)
 - 5-11 Sept '00
 - Gulf Coast Littoral
 - VRC 99 A / WaveLAN / Airborne relay / EUTs
 - Planning in progress w/ SPMAGTF / MCWL
- ⚡ FST-3
 - Target dates 19-23 Feb '01
 - SSC Lab SD, Camp Pendleton, NAS EI Centro, USS Coronado, ARG ships
 - ELB Contractors, SPMAGTF / I MEF / C3F participation
 - Focus: Rehearsal of MSD II
- ⚡ KB(X)
 - June '01
 - MSD II, Capable Warrior, FBE I

DM-1195/20

24 MONTH SCHEDULE

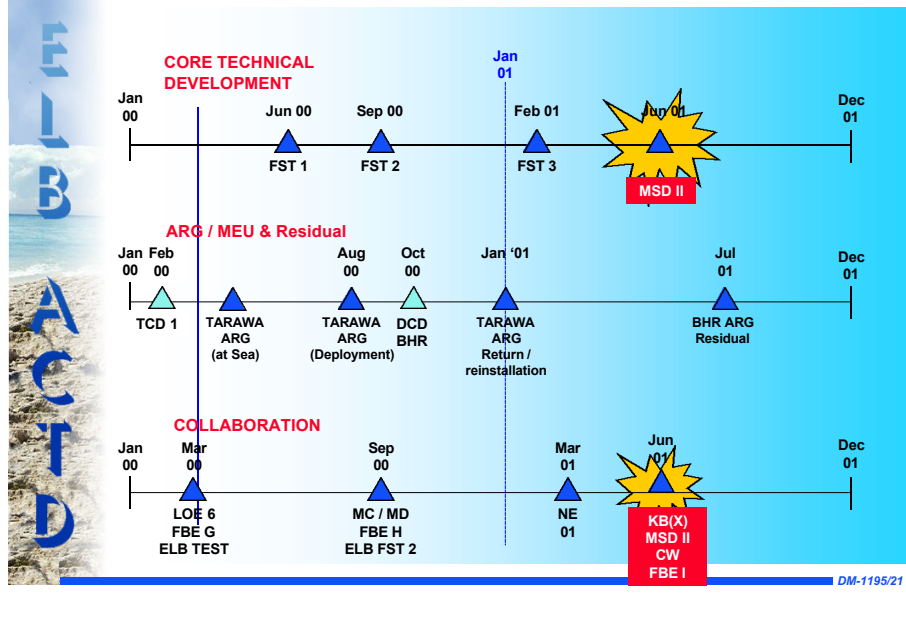

SUMMARY

- ✦ **Enhanced situation awareness!**
 - ✦ **Enhanced lethality & survivability**
 - ✦ **Residual / transition programs - TARAWA ARG / BHR ARG**
 - ✦ **Speeding Technology to the WARFIGHTER**
 - Integrating
 - Demonstrating
 - Deploying
 - Transitioning
 - ✦ **Ahead of our time**
 - Network protocols / MGMT
 - Handheld (Type 1 cert / IP addressable)
 - Airborne relays
- DM-1195/22

BACKUPS



DM-1195/23

RAPID TECHNOLOGY INSERTION TO ADVANCE WARFIGHTING IN THE LITTORALS

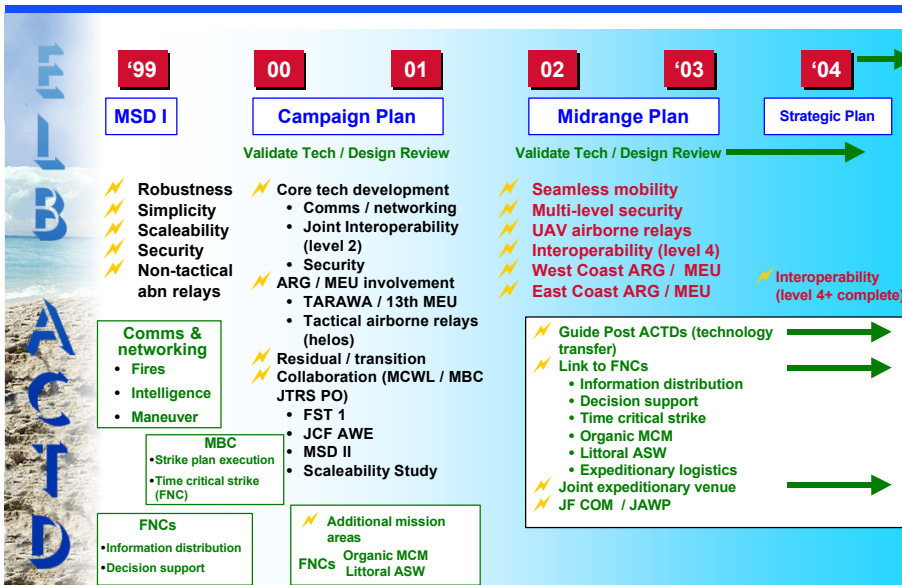

DM-1195/24

Decision Support: An Operational Perspective

Colonel Robert Schmidle

Commanding Officer Special Purpose Marine Air Ground Task Force Experimental

Since 1997 the Marine Corps Warfighting Laboratory (MCWL) has been conducting concept-based experimentation. During this time I have served as either the Second-in-Command or the Commanding Officer of the Special Purpose Marine Air Ground Task Force (Experimental) (SPMAGTF (X)); the unit tasked with executing these experiments for the MCWL. The focus of the paper is on the impressions from that experience that bear on the use of decision support by operational commanders. Decision support is often misunderstood as simply appliquéing technology onto existing structure and procedures; in fact it entails potentially significant changes to the current organizational paradigms. We will begin examining the concept of decision-support by discussing the three major experiments conducted to date, Hunter Warrior, Urban Warrior, and Capable Warrior. We do this in order to establish an operational context. Next, we will frame the issues that influence decision-making and delineate the requirements for decision-support that arise from those issues. Lastly, we will conclude with a look ahead to the future applications and potential of decision-support.

In any organization there are different tiers of decision makers but ultimately everyone in an organization whether it is a military unit or a large corporation is a decision maker. In a military unit organized for combat there is a place that exists specifically to facilitate decision-making; that is a Combat Operations Center (COC). In the COC decisions are made, and actions directed, that are necessary to accomplish the mission of that organization. The SPMAGTF (X) established an Experimental Combat Operations Center (ECOC) in order to facilitate the decision making required to exercise command and control of experimental forces. The ECOC also served as a test bed for experimenting with different organizational structures, procedures, and technologies. Implied in all of this experimentation is the goal of enhancing the performance of the commander and his staff, which is manifested in increased operational tempo, made possible by quicker more efficient decision-making. General George Patton is often quoted as saying that: “an average plan executed violently today is better than a great plan executed next week.”¹ The goal of decision support, and the associated ability to enable rapid, real time planning and execution of multiple courses of action, is to enable the commander to execute a "great plan" today.

The first experiment conducted by MCWL was the Advanced Warfighting Experiment (AWE) Hunter Warrior conducted in March 1997. It was the first in the Warrior series of experiments. The SPMAGTF (X) set up the ECOC in Camp Pendleton, CA (simulating a ship board COC) in order to command and control experimental forces in 29 Palms, CA (160 miles inland). Figure 1 shows the layout of the first ECOC.

¹George S. Patton Jr. *War As I Knew It*, Houghton Mifflin Company, May 1995, p. 265.

HUNTER WARRIOR ECOC

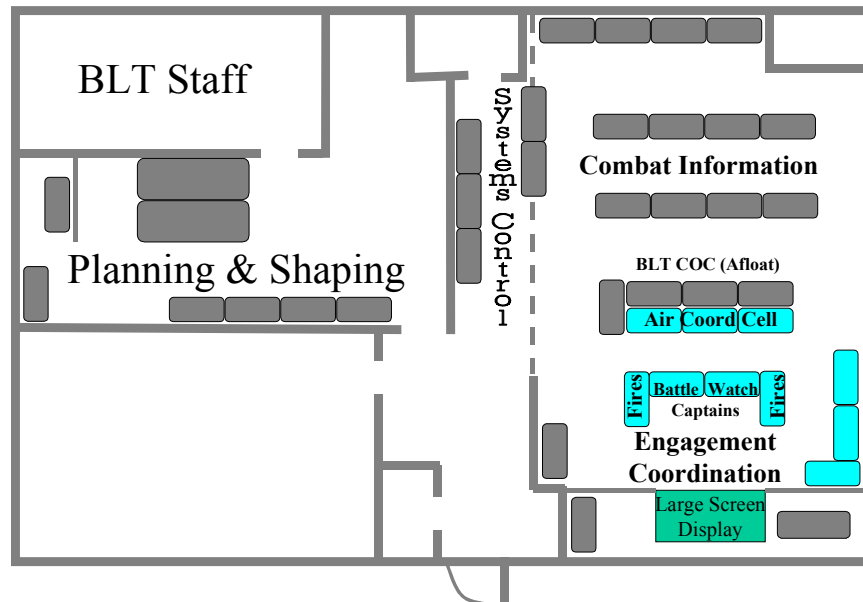

Figure 1

Of note is the different organizational structure that was employed in the experiment. This included the position of the Battle Captain, an officer who was more than simply a watch officer. He was empowered to make decisions regarding the execution of the current fight as well as to initiate branch planning for the next battle. The layout, however, was such that it was difficult for the necessary interaction to occur between the functional cells without deliberate movement on the part of the staff members. The staff was continually faced with deciding whether to stay at their workstations and interact with the programs and software that were intended to give them greater situational awareness (SA) or leave their computers and interact with the rest of the staff.

During this experiment, the majority of the time the staff members chose to stay at their workstations. This had the effect of funneling information vertically in the organization vice horizontally, which caused most all decision making in the ECOC to be centralized with the battle captain and the commander. While on the surface it appears that this is in fact the way decisions should be made, there are in fact, many more “supporting” decisions that a staff makes that enables a level of synchronization which in turn insures effective execution of those decisions. In fact, the physical layout of that particular ECOC did not improve the flow of information that was necessary in order to enhance the entire decision process.

Information flow is not only critical in and of itself, but also determines, to some extent, where decisions are made. The ergonomics of a COC will effect how and where information flows. Throughout any operations center there will be a number of nodes that represent the confluence of information as it flows from various sources. Those nodes, in turn, become both a physical

location and a conscious “place” in which decisions will naturally occur and to which decision makers will gravitate. When the activity level in the ECOC increased, the primary decision makers would physically move to the place where they “felt” they had the most situational awareness.

This experiment also saw the nascent use of visualization tools to, among other things, enable the commander and his staff to more readily determine the “pattern” of enemy movement. In this experiment the enemy was the 7th Marine Regiment, which was deployed in the field at 29 Palms, CA. Since a human being was directing the enemy force and humans tend toward patterns in activity, it is natural to assume that the enemy would eventually display patterns that could be exploited by the SPMAGTF (X). Exploited that is, if those patterns could be determined. There are however, at least two levels of activity in which patterns are evident. The first level is historical; it consists of the movement of the enemy troops, vehicles, etc. This is the level at which most “pattern recognition” is done and most decisions are made. The second, deeper level of activity is predictive; it consists of analysis of the enemy commander's intent based on observed or intuited patterns of the psychological factors that caused the activity in the first level. This second level is the one at which the ultimate victory or defeat of a unit is determined. After the unexpected and overwhelming victory by the Confederate Army at Chancellorsville, VA in 1863, Gen Robert E Lee was reported to have responded to a question from a Richmond newspaper about the risky tactic of dividing his army in the face of a numerically superior enemy, by simply stating: “that he was fighting Joe Hooker.”² Lee had long standing knowledge of Gen Hooker to prepare him for that decision, is it possible for a decision support system to provide today's commanders with that same type of knowledge about an enemy commander?

The next in the Warrior series of experiments, Urban Warrior saw a radical change in the layout of the ECOC. The change was based on a number of factors, beginning with a reevaluation of the process of information flow and decision-making. To review for a minute: a Combat Operations Center (COC) exists to facilitate decision-making, those decisions enable the execution of the six Battlespace functions that any COC must execute in order to be effective. Those functions are – Command and Control, Maneuver, Fires, Logistics, Force Protection, and Intelligence. In the ECOC those functions would likewise be performed, but the internal processes and procedures for execution would continue to be modified in the course of experimentation. Shortly after the Hunter Warrior experiment the MCWL participated in the “Traders Game” in New York City. This game consisted of interaction with the traders at the New York Mercantile Exchange and with the trainers of the New York City Fire Chiefs.

The traders on the Mercantile Exchange make hundreds of decisions a day, or in some cases in an hour, in a seemingly chaotic environment. The primary cues for initiating decisions or actions on the part of the traders come from visual displays of information (the latest quotes for instance) from which they recognize and interpret patterns of rising or falling commodity prices. After observing the traders for two days and participating in a “trading” session it was apparent that the horseshoe shaped “pit” in which they traded was an effective way to exchange information and effect the coordination necessary to execute trades. This physical layout also facilitated the human networking and interaction so critical to high tempo operations. Figure 2 shows the layout of the ECOC used in the AWE Urban Warrior aboard the USS Coronado in March 1999.

² Shelby Foote. *The Civil War, A Narrative*. First Vintage Books, 1963 p. 307.

URBAN WARRIOR ECOC

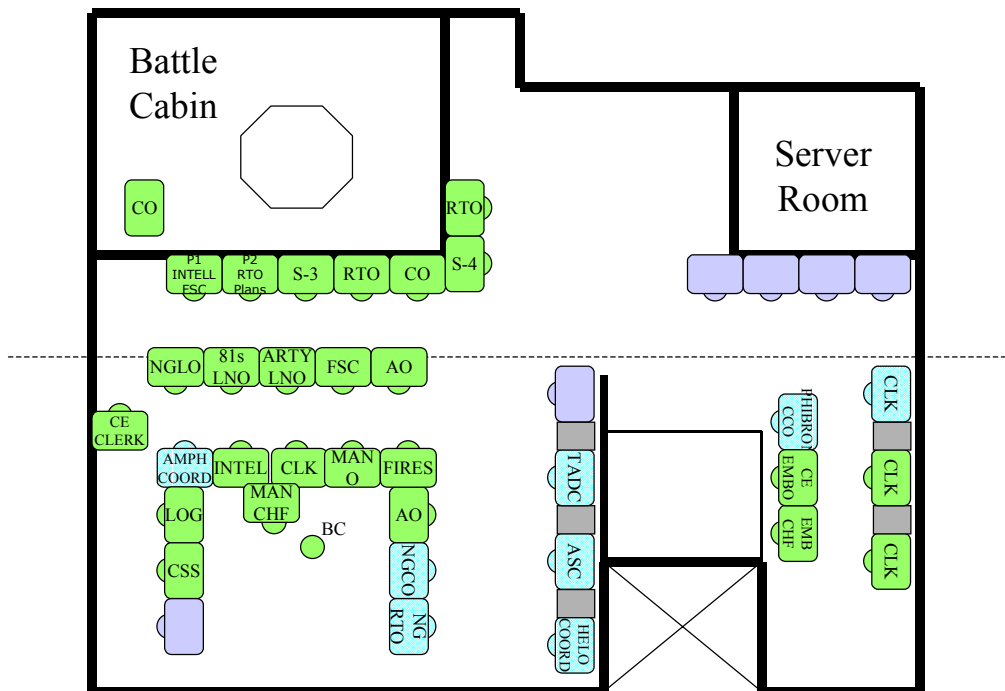

980929

Figure 2

Note that the flow of information is now potentially more circular, swirling around, and ultimately focused inward toward the pit of the horseshoe. In the pit is the “Battle Captain” an officer charged with the conduct of the current battle. The Battle Captain (BC) was envisioned to be the commanders representative, making the numerous decisions required to execute the operational plan. He would be an individual trained in the techniques of pattern recognition and experienced in the art of Recognition Primed Decision Making³. The role of the BC was now inspired in part by the MCWL experience with the New York City Fire Department’s course for training Fire Chiefs. This course consisted of a series of situational decision games designed to evaluate the firefighters ability to deal with numerous, stressful situations while simultaneously giving the participants valuable experience on which to base their future decisions. The course was the model for what eventually became the Combat Decision Range (CDR). In terms of the decision process in the ECOC the most useful insights concerned how a Chief would deal with the multiple challenges that arose at any fire and how he interacted with his subordinates. For example: the need for a Chief to quickly gain Situational Awareness (SA) as he approached a fire and then to influence the situation once he arrived is not unlike that of a commander confronted with a new situation in a COC. The commander has a continuous requirement to gain and maintain SA of both current and future operations. In the ECOC the commander could physically

³ Gary Klein, *Sources of Power* Cambridge, MIT Press, 1998.p.17.

position himself where he thought he could best influence events. That might be in the pit, directly involved in making decisions, or outside the horseshoe, detached from the fray, influencing more indirectly. The latter technique was more common, it also was coincident with the findings of Klein Associates in their numerous observations of COC operations. Those findings indicated that the person that generally had the most SA in a COC (or an aircraft cockpit) was not necessarily the one most involved in the execution, but more often was someone on the periphery, assimilating information and interpreting events as they unfolded.⁴

In addition to experimenting with a different physical layout, the ECOC in Urban Warrior also incorporated Expert Agents into the Integrated Marine Multi Agent Command and Control System (IMMACCS) software. This was the first time that agents were used to facilitate decision-making. They worked as they were designed, providing alert clues in response to programmed algorithms. The potential of this technology however, was not, and to date still has not, been realized. It is important to note that the SPMAGTF(X) views the agents as a decision aid and not as a decision maker. If Klein is correct in his postulation that expert decision makers make decisions based on raw data and not on processed information, then among the functions of the expert agents is to enhance the presentation of that data to the human decision maker.⁵ Agent functionality would also include performing various lower order tasks necessary to enable the execution of those decisions. For example, expeditiously performing the numerous, often-tedious calculations required to determine if a potential course of action being considered by the commander is logistically supportable.

The ECOC layout for Urban Warrior proved to be a mixed success. On the one hand the flow of information throughout the ECOC and the level of SA among the staff members was considerable higher than in previous experiments. However, the horseshoe configuration central to the ECOC, when set up aboard the USS Coronado for Urban Warrior did not work as well as we had hoped. This was principally due to two factors: first, in order to have enough room to accommodate the personnel operating in the center or pit, the horseshoe had to be widened to the extent that it made verbal cross communication difficult, second, the size and height of the computer screen in front of the operators (who faced inboard toward the pit) made visual communication among the staff difficult as well. Regardless of the technology incorporated into the ECOC, the human interaction required to generate high operational tempo is still most effectively accomplished by direct (unaided by electrons) verbal and visual communication.

At the conclusion of Urban Warrior, the SPMAGTF(X) stayed aboard the USS Coronado in order to execute the Extending the Littoral Battlespace (ELB) Advanced Concepts Technology Demonstration (ACTD) Major System Demonstration One (MSD-1). This was the first time that the SPMAGTF(X) had assumed the role of a Joint Force headquarters. The physical layout of the ECOC remained the same for MSD-1 as it was for Urban Warrior. The joint warfighting environment provided increased impetus for the need to address the issue of the method and content of information displayed to the decision makers. This was because the staff operating in the ECOC was now an ad hoc organization possessing limited familiarity with the equipment and each other. One thing that did, however, remain the same was that the more we experimented the more evident it became that Klein was correct in his conclusion that experienced decision makers

⁴ Ibid,p.118.

⁵ Ibid,p.160-174.

desired raw data (which they assimilated very quickly), not the processed information euphemistically called knowledge. Since raw data is potentially available more readily and more rapidly it is reasonable to assume that if you could get that data directly to the decision makers they could make faster and more effective decisions. Analyzing and filtering data, which is the current paradigm, provides an analytic construct that appears contrary to the way experienced officers actually make decisions.

For the next series of experiments, Capable Warrior, the physical layout of the ECOC again underwent significant changes. The experiences and lessons from the previous experiments were iteratively applied to the Capable Warrior ECOC. The most significant change was the dissolution of the horseshoe shape and the implementation of a rectangular configuration in the center of the ECOC to accommodate the "mission team." The concept of a mission team is one that we again owe to Klein. It is designed to enhance human interaction and information flow by locating the workstations of key staff officers in such a manner that communication between them was enhanced. Enhancing communication and subsequently increasing a sense of shared situational awareness also accelerated the dynamic of team building. That dynamic can best be described as linking people in an organization together first, and then connecting them with tasks. Consequently, operations in the ECOC, based on Standard Operating Procedures (SOPs), focused on supporting the mission team's execution of the current operation. That operation could range from combat to humanitarian assistance; the assigned members of the mission team reflecting the specific requirements of a given mission. For example in a humanitarian assistance operation, a supply officer or a medical officer might replace the fires officer. Figure 3 is the layout of the ECOC for the Capable Warrior experiments.

CAPABLE WARRIOR ECOC

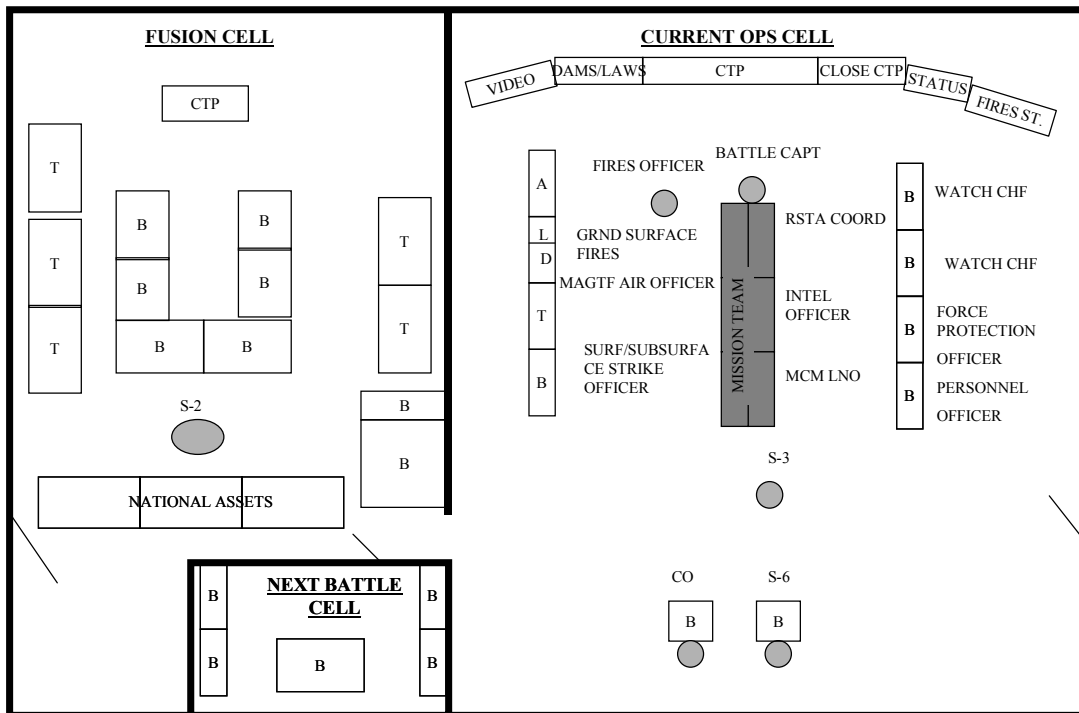

Figure 3

Note that there is not an individual workstation for the Battle Captain, Fires Officer, or the Operations Officer. These three officers are crucial to the operation of the ECOC and continued experimentation verified that they were best able to coordinate the activities of the ECOC by moving about and influencing events at what they determined to be a decisive time and place. The workstation for the Commander was used mostly for collaborative planning with higher, adjacent and subordinate commands. The commander generally moved about the ECOC or if he did sit, it was in close proximity to the mission team. This layout proved to be the most effective to date in terms of the execution of the battlespace functions discussed earlier. The growth in capability of the expert agents also continued. Most significant was the addition of the capability for the Fires Agent to "recommend" suitable weapons-target pairing for fire missions. This capability allowed weapons-target pairing to be done at any terminal in the network. Therefore, it was no longer necessary for the decision about the suitable pairing of a firing asset to a particular target to be confined to the ECOC. That decision could now be made anywhere in the network, however, the implications of this are still not fully sorted and there are issues of allocation authority that need to be considered. This capability however, could help enable the evolution of our current control dominated hierarchy command and control system into a more adaptive, coordinated, and self-synchronizing system.

The next section of this paper will examine the requirements for decision support for the Joint Force commander. To begin with, the information the decision makers need must be available to them in a form that contains the appropriate information and is easily assimilated. For example, consider the different way that the same information is displayed in Figures 4 and 5.

Weather

25 Apr 00	04L 05L 06L 07L 08L 09L 10L 11L 12L 13L 14L 15L 16L 18L 19L 20L 21L																		
MIN CIG	OVC050						SCT100				BKN250								
MIN VIS	6-SHRA																		
SFC WINDS	24015KT			24010KT						24012KT									
FLGT Hazards	No Turbc																		
Temp	30	29	28	27	27	26	26	25	25	25	24	34	34	23	25	26			
Light																			
Illum	20%	17%	05%	0%	05%	20%	25%												
Moon AZ	176			203		237		258		260		269							
Moon EL	70	64	56	47	31	23	4	-11	-23	-33	-48	-55	-67						
	BMNT 26/0538 SR 26/0630 SS 25/1725 EENT 25/1817 MR 26/1258 MS 26/0043																		

Figure 4

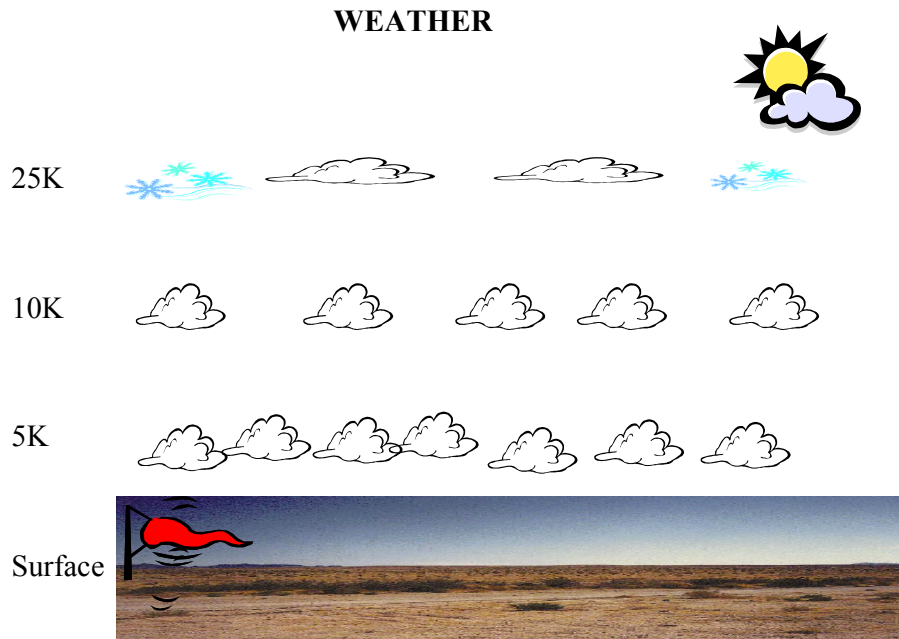

Figure 5

The written weather report in Figure 4 is impossible to understand unless one is well versed in the acronyms and even then it requires some interpretation. Contrast that display of information with Figure 5 in which the information is displayed in a way that brings about nearly instantaneous recognition of the current weather. The displays in a Combat Operations Center should, it seems evident, be more like Figure 5 than figure 4. It has been said that the knowledge we humans are capable of possessing is limited by our language. I would suggest that we could expand the notion of language to include all sensory inputs (visual, tactile, etc.) in which case the medium of information exchange becomes even more central to any consideration of decision support. How the information is presented to a decision maker will affect the level of knowledge extrapolated from that information, which in turn will affect the quality and timeliness of a given decision.

The future of decision support for the warfighter will certainly be influenced by technology. It will, however, also be influenced by an understanding of a new worldview. A complex system model is coming to be increasingly accepted as valid; replacing the traditional cause and effect model most common in a linear mechanistic Newtonian worldview. Complex systems are nonlinear, interactive systems that more accurately model events as they really occur, i.e. that the effect (the manifestation of an action) is rarely proportional to the initial cause. For example, the actions of a young Marine, as a member of a Joint Task Force engaged in Peace Keeping operations can have an unpredictable, strategic "effect," well out of proportion to the local, tactical "cause." Inputs no matter how seemingly insignificant can and will have an effect on a given situation. Heisenberg's uncertainty principle states that even the act of observation has an effect on the outcome of an experiment.⁶ The implication for decision support is that there must be an understanding that the effect of a decision will rarely have a proportional cause. In other

⁶ Douglas C. Giancoli, *The Ideas of Physics*, Third Edition, Harcourt, Brace, Jovanovich, 1986, p. 463.

words, expecting a decision to yield a predictable linear result is simply unrealistic and any attempt to do so is to confuse the desire to "control" a situation with the ability to actually "influence" that same situation.

Complex systems are open systems; they enable and encourage interaction between their components. The metaphor of a whirlpool is particularly applicable to understanding the relationship between organizations and complex systems. The interaction between the molecules of water in a whirlpool is continuous; it is what gives the whirlpool its shape. While the size, and to some extent the shape, of a whirlpool may change as the water flows through it, essentially it remains a whirlpool despite the fact that individual molecules (like individual people in an organization) come and go. Therefore, the interaction between people in a human system (i.e. a military organization) is what determines the essence of that organization; it also determines the form or shape of that organization.

A Complex Adaptive System is a complex system that continuously adapts to changes in its environment. As we discussed earlier, it is a delusion to think that one can, with certainty, predict all the consequences of a decision. What may be possible, however, is to predict the potential of emergent behavior in complex adaptive systems. Emergent behavior is the behavior that a system exhibits as it emerges or evolves to adapt to a situation. Behavior patterns generally can be predicted, but not specific behavior at a specific time. This is an area that has great potential for artificial intelligence agents as decision support aids. An agent for instance, could present to the decision maker predictions of potential patterns of emergent behavior in a complex adaptive system. That system could be the enemy as an entity itself or it could be the entity that is the behavior of the enemy and friendly forces taken together. Those patterns are the deeper form of pattern recognition discussed earlier. It is not the specifics of potential enemy courses of action that are of interest here, but rather the underlying patterns that determine those specifics.

The potential of decision support is also inextricably tied to enhancing the performance of an organization, whether that is an entire military unit or just the commander and his staff in the combat operations center. Performance enhancement can be realized by a number of factors ranging from training to technology. The presentation of information to the decision maker is one area in which technology offers great potential. Information should be presented for assimilation through multiple human senses. Visual, auditory, olfactory, and tactile sensations together form a richer, more complete "picture" of a given situation than any one of those sensations in isolation. For example, the presentation of Expert Agent alerts should be reflected in multiple mediums; visual, auditory, etc. In addition to the presentation of information, performance of a staff can be enhanced by a command and control system that enables rehearsal of potential courses of action. Rehearsal is important because it builds in the staff a mental picture of what the plan could look like, thereby giving decision makers a known point from which to deviate once the plan is put into operation. Rehearsal also provides the opportunity for decision makers to make decisions, and the more decisions someone makes the more experience they develop; consequently they are better prepared to make the decisions required when the operation actually unfolds.

Performance enhance can also be realized, and traditionally has been realized, by training. The challenge facing Joint Force Commanders is how to train a joint staff, which more often

than not is an ad hoc collection of personnel, in a relatively short period of time before that staff becomes operational. Here again the presentation of information could be in a format to elicit physiological reactions in the personnel that would encourage the dynamic of team building. For example, information presentations designed to cause a "fight or flight" reaction in the COC officers would also have the corollary effect of bonding the participants into a more cohesive human network. This is evident in the unifying effect that occurs among the recruits in Marine Corps boot camp when they are subjected to shared stress and hardship, both of which cause stimulation of the "fight or flight" reflex.

Decision support is the ultimate combat multiplier; it should enhance a commander's ability to defeat an adaptive enemy. That enemy will only be defeated by the strength of what Napoleon called the moral force, that imponderable combination of intellectual acuity and force of will. The strength of the moral force is manifested in suitable and opportune decisions. Those decisions should in turn create a tempo of operations with which the enemy is unable to cope. The friendly force's operational tempo is uniquely relative to the enemy's, but is generally characterized by overwhelming, violent, and unrelenting pressure on the enemy. That pressure starts and is sustained by timely and appropriate decisions. To paraphrase General Patton: "an intuitive decision, made instinctively now, is far more effective than an analytical decision, made carefully tomorrow." Bring on the Agents...

Decision Support: An Operational Perspective

Colonel Robert Schmidle

Commanding Officer Special Purpose Marine Air Ground Task Force Experimental

Since 1997 the Marine Corps Warfighting Laboratory (MCWL) has been conducting concept-based experimentation. During this time I have served as either the Second-in-Command or the Commanding Officer of the Special Purpose Marine Air Ground Task Force (Experimental) (SPMAGTF (X)); the unit tasked with executing these experiments for the MCWL. The focus of the paper is on the impressions from that experience that bear on the use of decision support by operational commanders. Decision support is often misunderstood as simply appliquéing technology onto existing structure and procedures; in fact it entails potentially significant changes to the current organizational paradigms. We will begin examining the concept of decision-support by discussing the three major experiments conducted to date, Hunter Warrior, Urban Warrior, and Capable Warrior. We do this in order to establish an operational context. Next, we will frame the issues that influence decision-making and delineate the requirements for decision-support that arise from those issues. Lastly, we will conclude with a look ahead to the future applications and potential of decision-support.

In any organization there are different tiers of decision makers but ultimately everyone in an organization whether it is a military unit or a large corporation is a decision maker. In a military unit organized for combat there is a place that exists specifically to facilitate decision-making; that is a Combat Operations Center (COC). In the COC decisions are made, and actions directed, that are necessary to accomplish the mission of that organization. The SPMAGTF (X) established an Experimental Combat Operations Center (ECOC) in order to facilitate the decision making required to exercise command and control of experimental forces. The ECOC also served as a test bed for experimenting with different organizational structures, procedures, and technologies. Implied in all of this experimentation is the goal of enhancing the performance of the commander and his staff, which is manifested in increased operational tempo, made possible by quicker more efficient decision-making. General George Patton is often quoted as saying that: “an average plan executed violently today is better than a great plan executed next week.”¹ The goal of decision support, and the associated ability to enable rapid, real time planning and execution of multiple courses of action, is to enable the commander to execute a "great plan" today.

The first experiment conducted by MCWL was the Advanced Warfighting Experiment (AWE) Hunter Warrior conducted in March 1997. It was the first in the Warrior series of experiments. The SPMAGTF (X) set up the ECOC in Camp Pendleton, CA (simulating a ship board COC) in order to command and control experimental forces in 29 Palms, CA (160 miles inland). Figure 1 shows the layout of the first ECOC.

¹George S. Patton Jr. *War As I Knew It*, Houghton Mifflin Company, May 1995, p. 265.

HUNTER WARRIOR ECOC

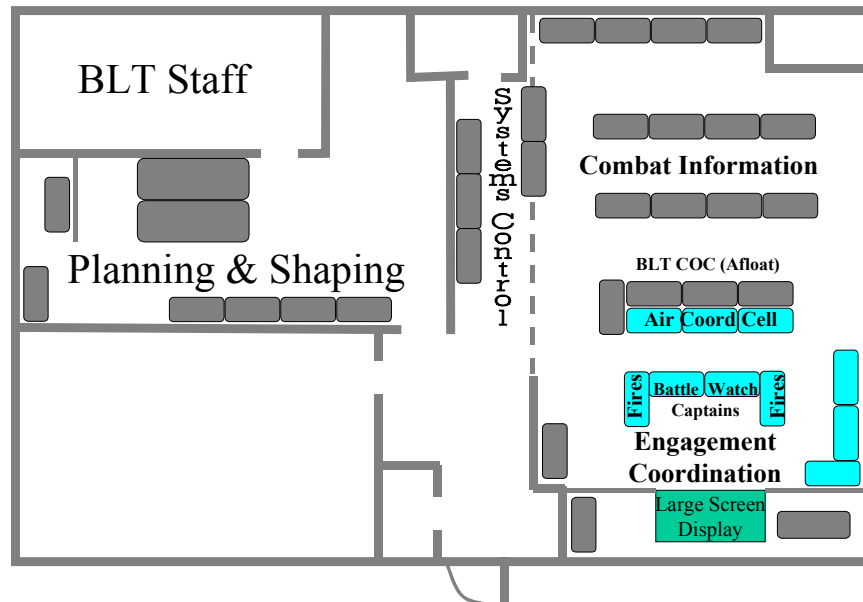

Figure 1

Of note is the different organizational structure that was employed in the experiment. This included the position of the Battle Captain, an officer who was more than simply a watch officer. He was empowered to make decisions regarding the execution of the current fight as well as to initiate branch planning for the next battle. The layout, however, was such that it was difficult for the necessary interaction to occur between the functional cells without deliberate movement on the part of the staff members. The staff was continually faced with deciding whether to stay at their workstations and interact with the programs and software that were intended to give them greater situational awareness (SA) or leave their computers and interact with the rest of the staff.

During this experiment, the majority of the time the staff members chose to stay at their workstations. This had the effect of funneling information vertically in the organization vice horizontally, which caused most all decision making in the ECOC to be centralized with the battle captain and the commander. While on the surface it appears that this is in fact the way decisions should be made, there are in fact, many more “supporting” decisions that a staff makes that enables a level of synchronization which in turn insures effective execution of those decisions. In fact, the physical layout of that particular ECOC did not improve the flow of information that was necessary in order to enhance the entire decision process.

Information flow is not only critical in and of itself, but also determines, to some extent, where decisions are made. The ergonomics of a COC will effect how and where information flows. Throughout any operations center there will be a number of nodes that represent the confluence of information as it flows from various sources. Those nodes, in turn, become both a physical

location and a conscious “place” in which decisions will naturally occur and to which decision makers will gravitate. When the activity level in the ECOC increased, the primary decision makers would physically move to the place where they “felt” they had the most situational awareness.

This experiment also saw the nascent use of visualization tools to, among other things, enable the commander and his staff to more readily determine the “pattern” of enemy movement. In this experiment the enemy was the 7th Marine Regiment, which was deployed in the field at 29 Palms, CA. Since a human being was directing the enemy force and humans tend toward patterns in activity, it is natural to assume that the enemy would eventually display patterns that could be exploited by the SPMAGTF (X). Exploited that is, if those patterns could be determined. There are however, at least two levels of activity in which patterns are evident. The first level is historical; it consists of the movement of the enemy troops, vehicles, etc. This is the level at which most “pattern recognition” is done and most decisions are made. The second, deeper level of activity is predictive; it consists of analysis of the enemy commander's intent based on observed or intuited patterns of the psychological factors that caused the activity in the first level. This second level is the one at which the ultimate victory or defeat of a unit is determined. After the unexpected and overwhelming victory by the Confederate Army at Chancellorsville, VA in 1863, Gen Robert E Lee was reported to have responded to a question from a Richmond newspaper about the risky tactic of dividing his army in the face of a numerically superior enemy, by simply stating: “that he was fighting Joe Hooker.”² Lee had long standing knowledge of Gen Hooker to prepare him for that decision, is it possible for a decision support system to provide today's commanders with that same type of knowledge about an enemy commander?

The next in the Warrior series of experiments, Urban Warrior saw a radical change in the layout of the ECOC. The change was based on a number of factors, beginning with a reevaluation of the process of information flow and decision-making. To review for a minute: a Combat Operations Center (COC) exists to facilitate decision-making, those decisions enable the execution of the six Battlespace functions that any COC must execute in order to be effective. Those functions are – Command and Control, Maneuver, Fires, Logistics, Force Protection, and Intelligence. In the ECOC those functions would likewise be performed, but the internal processes and procedures for execution would continue to be modified in the course of experimentation. Shortly after the Hunter Warrior experiment the MCWL participated in the “Traders Game” in New York City. This game consisted of interaction with the traders at the New York Mercantile Exchange and with the trainers of the New York City Fire Chiefs.

The traders on the Mercantile Exchange make hundreds of decisions a day, or in some cases in an hour, in a seemingly chaotic environment. The primary cues for initiating decisions or actions on the part of the traders come from visual displays of information (the latest quotes for instance) from which they recognize and interpret patterns of rising or falling commodity prices. After observing the traders for two days and participating in a “trading” session it was apparent that the horseshoe shaped “pit” in which they traded was an effective way to exchange information and effect the coordination necessary to execute trades. This physical layout also facilitated the human networking and interaction so critical to high tempo operations. Figure 2 shows the layout of the ECOC used in the AWE Urban Warrior aboard the USS Coronado in March 1999.

² Shelby Foote. *The Civil War, A Narrative*. First Vintage Books, 1963 p. 307.

URBAN WARRIOR ECOC

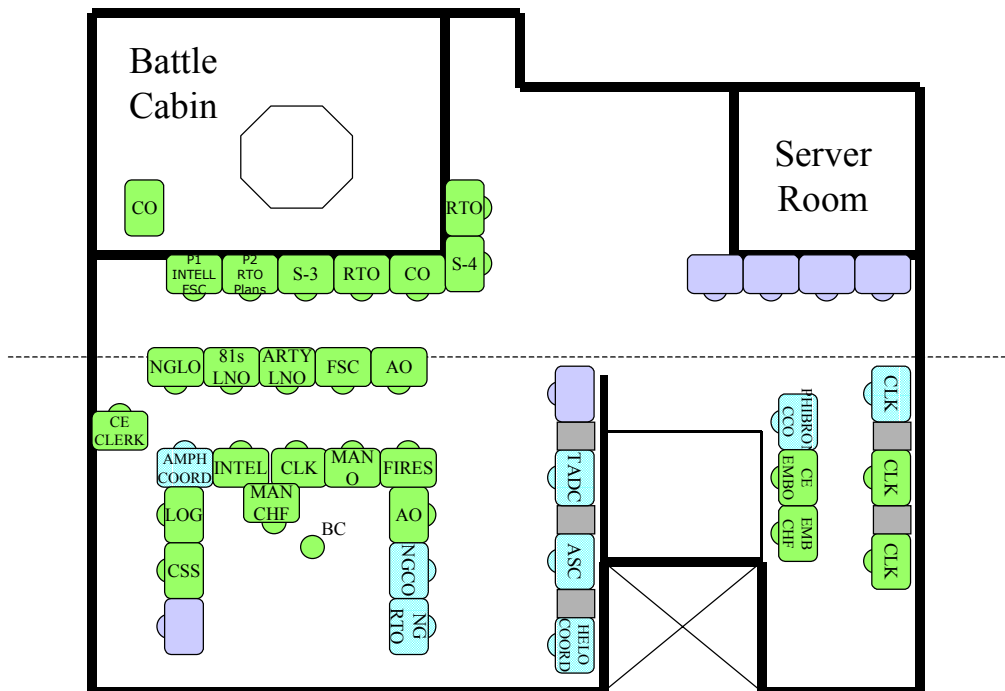

980929

Figure 2

Note that the flow of information is now potentially more circular, swirling around, and ultimately focused inward toward the pit of the horseshoe. In the pit is the “Battle Captain” an officer charged with the conduct of the current battle. The Battle Captain (BC) was envisioned to be the commanders representative, making the numerous decisions required to execute the operational plan. He would be an individual trained in the techniques of pattern recognition and experienced in the art of Recognition Primed Decision Making³. The role of the BC was now inspired in part by the MCWL experience with the New York City Fire Department’s course for training Fire Chiefs. This course consisted of a series of situational decision games designed to evaluate the firefighters ability to deal with numerous, stressful situations while simultaneously giving the participants valuable experience on which to base their future decisions. The course was the model for what eventually became the Combat Decision Range (CDR). In terms of the decision process in the ECOC the most useful insights concerned how a Chief would deal with the multiple challenges that arose at any fire and how he interacted with his subordinates. For example: the need for a Chief to quickly gain Situational Awareness (SA) as he approached a fire and then to influence the situation once he arrived is not unlike that of a commander confronted with a new situation in a COC. The commander has a continuous requirement to gain and maintain SA of both current and future operations. In the ECOC the commander could physically

³ Gary Klein, *Sources of Power* Cambridge, MIT Press, 1998.p.17.

position himself where he thought he could best influence events. That might be in the pit, directly involved in making decisions, or outside the horseshoe, detached from the fray, influencing more indirectly. The latter technique was more common, it also was coincident with the findings of Klein Associates in their numerous observations of COC operations. Those findings indicated that the person that generally had the most SA in a COC (or an aircraft cockpit) was not necessarily the one most involved in the execution, but more often was someone on the periphery, assimilating information and interpreting events as they unfolded.⁴

In addition to experimenting with a different physical layout, the ECOC in Urban Warrior also incorporated Expert Agents into the Integrated Marine Multi Agent Command and Control System (IMMACCS) software. This was the first time that agents were used to facilitate decision-making. They worked as they were designed, providing alert clues in response to programmed algorithms. The potential of this technology however, was not, and to date still has not, been realized. It is important to note that the SPMAGTF(X) views the agents as a decision aid and not as a decision maker. If Klein is correct in his postulation that expert decision makers make decisions based on raw data and not on processed information, then among the functions of the expert agents is to enhance the presentation of that data to the human decision maker.⁵ Agent functionality would also include performing various lower order tasks necessary to enable the execution of those decisions. For example, expeditiously performing the numerous, often-tedious calculations required to determine if a potential course of action being considered by the commander is logistically supportable.

The ECOC layout for Urban Warrior proved to be a mixed success. On the one hand the flow of information throughout the ECOC and the level of SA among the staff members was considerable higher than in previous experiments. However, the horseshoe configuration central to the ECOC, when set up aboard the USS Coronado for Urban Warrior did not work as well as we had hoped. This was principally due to two factors: first, in order to have enough room to accommodate the personnel operating in the center or pit, the horseshoe had to be widened to the extent that it made verbal cross communication difficult, second, the size and height of the computer screen in front of the operators (who faced inboard toward the pit) made visual communication among the staff difficult as well. Regardless of the technology incorporated into the ECOC, the human interaction required to generate high operational tempo is still most effectively accomplished by direct (unaided by electrons) verbal and visual communication.

At the conclusion of Urban Warrior, the SPMAGTF(X) stayed aboard the USS Coronado in order to execute the Extending the Littoral Battlespace (ELB) Advanced Concepts Technology Demonstration (ACTD) Major System Demonstration One (MSD-1). This was the first time that the SPMAGTF(X) had assumed the role of a Joint Force headquarters. The physical layout of the ECOC remained the same for MSD-1 as it was for Urban Warrior. The joint warfighting environment provided increased impetus for the need to address the issue of the method and content of information displayed to the decision makers. This was because the staff operating in the ECOC was now an ad hoc organization possessing limited familiarity with the equipment and each other. One thing that did, however, remain the same was that the more we experimented the more evident it became that Klein was correct in his conclusion that experienced decision makers

⁴ Ibid,p.118.

⁵ Ibid,p.160-174.

desired raw data (which they assimilated very quickly), not the processed information euphemistically called knowledge. Since raw data is potentially available more readily and more rapidly it is reasonable to assume that if you could get that data directly to the decision makers they could make faster and more effective decisions. Analyzing and filtering data, which is the current paradigm, provides an analytic construct that appears contrary to the way experienced officers actually make decisions.

For the next series of experiments, Capable Warrior, the physical layout of the ECOC again underwent significant changes. The experiences and lessons from the previous experiments were iteratively applied to the Capable Warrior ECOC. The most significant change was the dissolution of the horseshoe shape and the implementation of a rectangular configuration in the center of the ECOC to accommodate the "mission team." The concept of a mission team is one that we again owe to Klein. It is designed to enhance human interaction and information flow by locating the workstations of key staff officers in such a manner that communication between them was enhanced. Enhancing communication and subsequently increasing a sense of shared situational awareness also accelerated the dynamic of team building. That dynamic can best be described as linking people in an organization together first, and then connecting them with tasks. Consequently, operations in the ECOC, based on Standard Operating Procedures (SOPs), focused on supporting the mission team's execution of the current operation. That operation could range from combat to humanitarian assistance; the assigned members of the mission team reflecting the specific requirements of a given mission. For example in a humanitarian assistance operation, a supply officer or a medical officer might replace the fires officer. Figure 3 is the layout of the ECOC for the Capable Warrior experiments.

CAPABLE WARRIOR ECOC

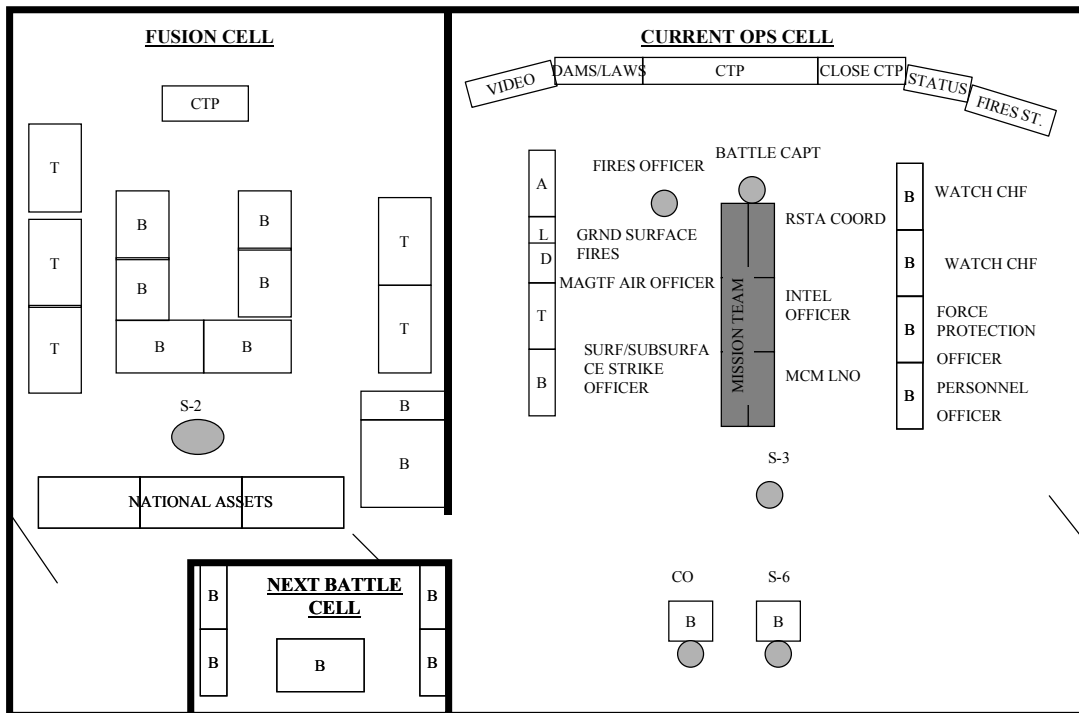

Figure 3

Note that there is not an individual workstation for the Battle Captain, Fires Officer, or the Operations Officer. These three officers are crucial to the operation of the ECOC and continued experimentation verified that they were best able to coordinate the activities of the ECOC by moving about and influencing events at what they determined to be a decisive time and place. The workstation for the Commander was used mostly for collaborative planning with higher, adjacent and subordinate commands. The commander generally moved about the ECOC or if he did sit, it was in close proximity to the mission team. This layout proved to be the most effective to date in terms of the execution of the battlespace functions discussed earlier. The growth in capability of the expert agents also continued. Most significant was the addition of the capability for the Fires Agent to "recommend" suitable weapons-target pairing for fire missions. This capability allowed weapons-target pairing to be done at any terminal in the network. Therefore, it was no longer necessary for the decision about the suitable pairing of a firing asset to a particular target to be confined to the ECOC. That decision could now be made anywhere in the network, however, the implications of this are still not fully sorted and there are issues of allocation authority that need to be considered. This capability however, could help enable the evolution of our current control dominated hierarchy command and control system into a more adaptive, coordinated, and self-synchronizing system.

The next section of this paper will examine the requirements for decision support for the Joint Force commander. To begin with, the information the decision makers need must be available to them in a form that contains the appropriate information and is easily assimilated. For example, consider the different way that the same information is displayed in Figures 4 and 5.

Weather

25 Apr 00	04L 05L 06L 07L 08L 09L 10L 11L 12L 13L 14L 15L 16L 18L 19L 20L 21L																		
MIN CIG	OVC050							SCT100			BKN250								
MIN VIS	6-SHRA																		
SFC WINDS	24015KT			24010KT						24012KT									
FLGT Hazards	No Turbc																		
Temp	30	29	28	27	27	26	26	25	25	25	24	34	34	23	25	26			
Light																			
Illum	20%	17%	05%	0%	05%	20%	25%												
Moon AZ	176			203		237		258		260		269							
Moon EL	70	64	56	47	31	23	4	-11	-23	-33	-48	-55	-67						
	BMNT 26/0538 SR 26/0630 SS 25/1725 EENT 25/1817 MR 26/1258 MS 26/0043																		

Figure 4

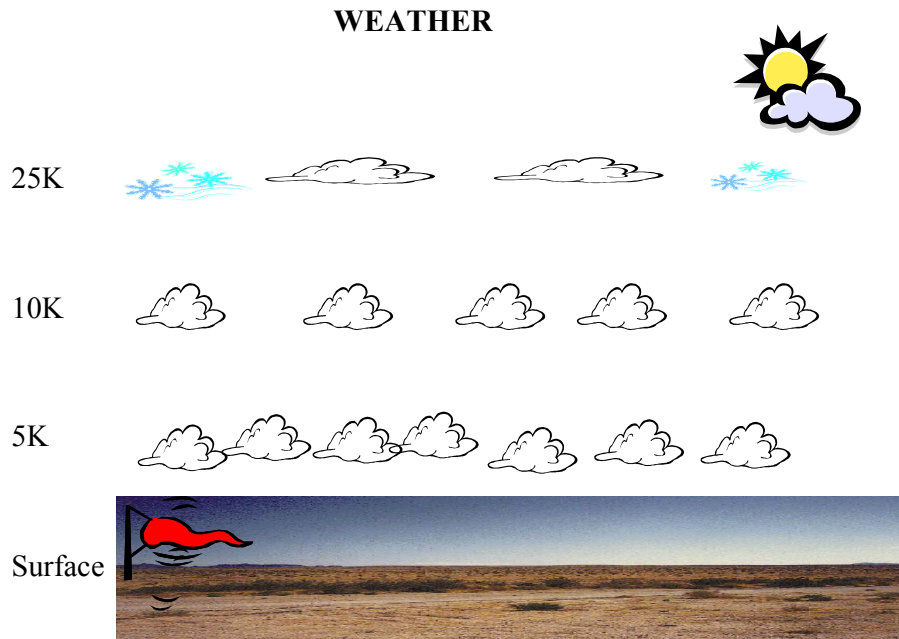

Figure 5

The written weather report in Figure 4 is impossible to understand unless one is well versed in the acronyms and even then it requires some interpretation. Contrast that display of information with Figure 5 in which the information is displayed in a way that brings about nearly instantaneous recognition of the current weather. The displays in a Combat Operations Center should, it seems evident, be more like Figure 5 than figure 4. It has been said that the knowledge we humans are capable of possessing is limited by our language. I would suggest that we could expand the notion of language to include all sensory inputs (visual, tactile, etc.) in which case the medium of information exchange becomes even more central to any consideration of decision support. How the information is presented to a decision maker will affect the level of knowledge extrapolated from that information, which in turn will affect the quality and timeliness of a given decision.

The future of decision support for the warfighter will certainly be influenced by technology. It will, however, also be influenced by an understanding of a new worldview. A complex system model is coming to be increasingly accepted as valid; replacing the traditional cause and effect model most common in a linear mechanistic Newtonian worldview. Complex systems are nonlinear, interactive systems that more accurately model events as they really occur, i.e. that the effect (the manifestation of an action) is rarely proportional to the initial cause. For example, the actions of a young Marine, as a member of a Joint Task Force engaged in Peace Keeping operations can have an unpredictable, strategic "effect," well out of proportion to the local, tactical "cause." Inputs no matter how seemingly insignificant can and will have an effect on a given situation. Heisenberg's uncertainty principle states that even the act of observation has an effect on the outcome of an experiment.⁶ The implication for decision support is that there must be an understanding that the effect of a decision will rarely have a proportional cause. In other

⁶ Douglas C. Giancoli, *The Ideas of Physics*, Third Edition, Harcourt, Brace, Jovanovich, 1986, p. 463.

words, expecting a decision to yield a predictable linear result is simply unrealistic and any attempt to do so is to confuse the desire to "control" a situation with the ability to actually "influence" that same situation.

Complex systems are open systems; they enable and encourage interaction between their components. The metaphor of a whirlpool is particularly applicable to understanding the relationship between organizations and complex systems. The interaction between the molecules of water in a whirlpool is continuous; it is what gives the whirlpool its shape. While the size, and to some extent the shape, of a whirlpool may change as the water flows through it, essentially it remains a whirlpool despite the fact that individual molecules (like individual people in an organization) come and go. Therefore, the interaction between people in a human system (i.e. a military organization) is what determines the essence of that organization; it also determines the form or shape of that organization.

A Complex Adaptive System is a complex system that continuously adapts to changes in its environment. As we discussed earlier, it is a delusion to think that one can, with certainty, predict all the consequences of a decision. What may be possible, however, is to predict the potential of emergent behavior in complex adaptive systems. Emergent behavior is the behavior that a system exhibits as it emerges or evolves to adapt to a situation. Behavior patterns generally can be predicted, but not specific behavior at a specific time. This is an area that has great potential for artificial intelligence agents as decision support aids. An agent for instance, could present to the decision maker predictions of potential patterns of emergent behavior in a complex adaptive system. That system could be the enemy as an entity itself or it could be the entity that is the behavior of the enemy and friendly forces taken together. Those patterns are the deeper form of pattern recognition discussed earlier. It is not the specifics of potential enemy courses of action that are of interest here, but rather the underlying patterns that determine those specifics.

The potential of decision support is also inextricably tied to enhancing the performance of an organization, whether that is an entire military unit or just the commander and his staff in the combat operations center. Performance enhancement can be realized by a number of factors ranging from training to technology. The presentation of information to the decision maker is one area in which technology offers great potential. Information should be presented for assimilation through multiple human senses. Visual, auditory, olfactory, and tactile sensations together form a richer, more complete "picture" of a given situation than any one of those sensations in isolation. For example, the presentation of Expert Agent alerts should be reflected in multiple mediums; visual, auditory, etc. In addition to the presentation of information, performance of a staff can be enhanced by a command and control system that enables rehearsal of potential courses of action. Rehearsal is important because it builds in the staff a mental picture of what the plan could look like, thereby giving decision makers a known point from which to deviate once the plan is put into operation. Rehearsal also provides the opportunity for decision makers to make decisions, and the more decisions someone makes the more experience they develop; consequently they are better prepared to make the decisions required when the operation actually unfolds.

Performance enhance can also be realized, and traditionally has been realized, by training. The challenge facing Joint Force Commanders is how to train a joint staff, which more often

than not is an ad hoc collection of personnel, in a relatively short period of time before that staff becomes operational. Here again the presentation of information could be in a format to elicit physiological reactions in the personnel that would encourage the dynamic of team building. For example, information presentations designed to cause a "fight or flight" reaction in the COC officers would also have the corollary effect of bonding the participants into a more cohesive human network. This is evident in the unifying effect that occurs among the recruits in Marine Corps boot camp when they are subjected to shared stress and hardship, both of which cause stimulation of the "fight or flight" reflex.

Decision support is the ultimate combat multiplier; it should enhance a commander's ability to defeat an adaptive enemy. That enemy will only be defeated by the strength of what Napoleon called the moral force, that imponderable combination of intellectual acuity and force of will. The strength of the moral force is manifested in suitable and opportune decisions. Those decisions should in turn create a tempo of operations with which the enemy is unable to cope. The friendly force's operational tempo is uniquely relative to the enemy's, but is generally characterized by overwhelming, violent, and unrelenting pressure on the enemy. That pressure starts and is sustained by timely and appropriate decisions. To paraphrase General Patton: "an intuitive decision, made instinctively now, is far more effective than an analytical decision, made carefully tomorrow." Bring on the Agents...

Knowledge Superiority

RDML Charles L. Munns, USN
Deputy Chief of Staff for C4I, Resources, Requirements, and Assessments

Roadmap to Knowledge Superiority
Barriers to Collaboration and Information Sharing
Decisions – Fleet Perspective Presentation

Roadmap Toward Knowledge Superiority

We must prepare our Navy for tomorrow. In the future, the availability and capability of our people and equipment remain important parameters for success, and there are many parts of our Navy working on these issues. The Navy's responsibility, as executors of our processes, must be to nurture our processes and where appropriate drastically change them for operations (some would say survival) in the 21st century. Therefore, this paper is to discuss some actions we must take to lead change for the future.

The world has changed in some very fundamental areas over the last decade – a digital and network explosion, world politics, global press, international economics and trade, different budget pressures and so on. You have heard these changes discussed many times, I won't expound on them here. The implication, however, is significant for us. Our strategy as we operate in this new environment and into the next century is based on assured access and knowledge superiority. We have access today and you all intuitively understand it, we have lived it throughout our careers. We don't have knowledge superiority and we don't yet fully understand it. This paper is to discuss leading change in the context of achieving knowledge superiority.

Knowledge superiority has many facets. It will give us better and more appropriately timed decisions, so that we can take more effective and efficient actions. We will achieve this through a much more organized and collaborative use of our collective information and by networking our equipment, our people and our data. This will require new processes, new attitudes and new ways of doing our business. Success in the future will not be just about physical strength or size. Those are important, but the team that wins will be the one that makes the best use of its information and are agile in doing so. This has always been important, but it is increasingly so today. Technology and the potential of asymmetric challenges have dramatically increased the value of this information.

Knowledge superiority (KS) will effect everything we do to include a significant influence on three distinct aspects of our Navy. First it will enable a new and significantly more powerful and more effective level of warfighting. It will bring us enhanced capabilities as nuclear power did for the submarine, carrier aviation did for our capital ships, and amphibious landings for the Marine Corps. Secondly, KS will bring efficiency and effectiveness to the support side of our Navy. It will help us operate as a world class business, where we know what things cost, and where and when to invest to achieve the most bang for the buck or the best

retention. Thirdly, KS will provide for a much enhanced Quality of Service experience for our Sailors. It will provide a modern work place, an efficient support structure, the tools Sailors need to efficiently do their jobs – it will increase productivity and make the Sailor proud of his or her Navy work place and job experience.

We are beginning a journey toward something new. In the end we will have changed everything, the tools we use, the way we operate, the way we organize, the way we train, and the way we interact. We don't know the end state other than to sense it is very important, but I can outline below some first steps we should take. As we transition to a network culture the change we must foster will be like that our forefathers managed in going from an agrarian to industrial society. It's as if we were leaders of a 400,000 person farming community today and to acquire more capability, to achieve more power, we decide we have to convert to an industrialized society. We would proceed in a bottom up fashion to build common infrastructure: roads, power systems, water networks, phones etc. With that started we would organize around that infrastructure: set policies, and rules for driving the roads, set interoperability standards for the electrical systems and form police departments, establish phone books and street addressees. Then we would change our agrarian processes to take full advantage of the new capability: we would set up assembly lines, create business rules, build malls etc.

Our journey now is to do likewise as we move from the industrial culture of the last century into the networked and information society of the next century. We must start by building the infrastructure, the network. We then must organize our information on that network, and finally change our processes. We are several years into this journey already... let me summarize our current efforts and what we need to do this next year. These are the steps we need to take.

Step 1: Build a network centric infrastructure: Complete IT21 afloat, field the Navy Marine Corps Intranet (NMCI) ashore and train all our people in basic network and information skills. Our progression should be from computer illiteracy, through individual digital computing to networked interactions of our people and data. We are currently working on the last step. IT21 brings the network to our ships, the CINCPACFLT (CPF) Base Area Network are the first steps toward NMCI. These projects move our shore structure from a bunch of individual computers and support cells toward a coordinated collection of connected regional networks, with security built in from the start. This network and these network services should be regionalized. We must consolidate our physical network talent that is resident in individual commands today into Regional Information Technology Service Centers (RITSC), and they must provide a reliable, consistent, secure network “dial tone” for everyone in the region. We are starting this consolidation within CINCPACFLT (CPF) claimancies, but NMCI will make it Naval wide.

Step 2: Organize our information: Make use of the network. Its purpose is for much more than just emails. We should begin to work off “common table tops” of information, to work collaboratively on documents, to share information across individual and command boundaries all for the purpose of getting our information to more efficiently and effectively influence our actions. The first steps are to develop an information management (IM) capability within each command; to assign command and regional information managers; to educate our people in these new information skills; to start the process of designating data owners, and to specify

authoritative data sources. We are beginning to think of three levels of data and/or applications: personal, regional and global. Our goal where applicable is to mature data and applications, to move them from the personal domain into the regional or global domain. As they mature they must become interoperable with network policies: firewall, VPN, addressing, data definitions, data ownership, data health, enterprise processes, bandwidth, latency, scalability etc. This will be long and tedious, but we will just eat away at them one bite, one application one data source at a time. Two groups will lead us as we continue down this path our RITSCs who will provide regional network service and individual command IM talent. Both must work together. Both must work up and down the chain of command.

Step 3: Change our Processes: This is the big pay off, that which gives our new Navy a quantum increase in capability and efficiency over today's world. Initial steps have been taken by the CPF solution provider initiative. Over the past two years it has worked within CPF staff and their three TYCOMS and this year it's focusing on Fleet processes through the Stennis and BonHomme Richard deployment. COMTHIRDFLEET has stood up a Network Centric Innovation Center (NCIC) to capture the lessons learned on JCS/BHR, to gather those already learned on previous deployments and to fold them into succeeding CVBG/ARG deployers. To begin the formalization of tactics, techniques and procedures for the new network centric Navy, we are experimenting with these initiatives at the Global War Game series and in our Fleet Battle Experiments. The best process changes are the ones that bubble up from the bottom, providing they are consistent with our IT and data architecture. We must encourage these initiatives, capture their ideas, and mature them but also make sure they will work on the global network. A Process Coordination Center is being stood up at CPF to facilitate this effort. It will be tasked to act as a resource for process change initiatives, to help coordinate those initiatives and to mature solutions that have regional and global applicability.

This is the path we are on as we lead change in the CINCPACFLT and move to a network centric environment and toward knowledge superiority. First, build the infrastructure and then in an iterative fashion organize our data on a regional table top and change our processes. There are some fundamental principles that are implicit in this journey: bottom up innovation, sharing of information, regional computing, group effort which coordinates individual skills, just one network, growth of regional and enterprise data sources, individual horizons that are flatter but much broader, capacity for faster decisions, monitoring more and directing less, central standards and de-centralized actions, communities of interest, transparency of information (within the approved organization), and many more that we have yet to discover.

In summary we need to:

- Continue building the network (IT21, CPF BANs then NMCI, train our people)
- Form and participate in regional network governance (RITSCs)
- Develop IM skills within our organizations.
- Continue to better manage our information and to move it from individual to regional or global capabilities.
- Change our processes to move away from our current industrial mindset toward a network and information rich culture.
- Foster innovation, capture the great ideas of our people

There is a huge payoff for us when the Navy makes this transformation. However, to get there will take the combined efforts of us all. The inertia of bureaucracy is against us --- many are comfortable with our current industrial age processes. This journey into the future will take vision, bold actions, and trust in our instincts.

Barriers to Collaboration

What are the requirements which enable the Navy to effectively collaborate - to enhance the quality, timeliness and impact of our decision making process? Industry has discovered – as have we at CINCPACFLT Headquarters – that the adage of “if you build it they will come” is necessary but probably not sufficient. In addition to having people in the organization that understand the need and value of collaboration and their having access to collaboration tools, there seems a need for something more. It requires a dedicated, coordinated effort across the Navy. That effort is essentially comprised of three pieces. There is the technical piece, the financial piece and the cultural piece. All three pieces need to be developed and integrated into a cohesive whole for us to effectively leverage the power of global access and collaboration to strengthen our decision-making. If successful, the impact of collaboration will be felt throughout the tactical-through-strategic levels and across the administrative-through-operational realms.

Within the technical piece, the hardware must be sufficient to allow every naval member access to the IT environment. The connectivity must be universal, secure and bandwidth considerate. The software must be interoperable. The administrators must be trained to keep it all functioning and the users must be trained in how to use the software and how to employ software services to enhance their work, their decision support and their ultimate decisions. The data architecture for the stored information must be wisely crafted and rigorously applied to ensure redundant and contradicting information can be identified and eliminated. The data input procedures must be such that data elements are entered once and then be available to and used by all that need them.

Within the financial piece, we must learn to adequately and rightly fund the IT enterprise. This is an enormous challenge for our organization which is built on a vertical “platform” orientation. Collaboration is a horizontal function. Our system has difficulty resourcing the horizontal capabilities.

Another difficult aspect of the financial piece is the accounting for and distribution of savings. Collaboration has its value, but the value’s estimation is often hard to determine, demonstrate or equate to dollars saved. Value determination is also difficult by the benefit of collaboration being realized, most often, across organizational lines. What resource sponsor gets credited with the savings and how do we redistribute the savings to pay for the costs of collaboration? Let’s use the example of an enterprise-wide Timekeeping tool. Suppose that DFAS sponsored the development, training and deployment costs. But who funds the integration, maintenance and support costs after the tool has been employed and where does the time saved accrue? In the back office or in the front office?

The third piece of the dedicated effort to implement collaboration in the Navy is the cultural one. Does collaboration and information sharing come naturally to humans? Some will say it does and cite the fact that we actually do it all the time -- in coffee rooms, over lunches, in professional journals and in meeting rooms -- as proof. Some say that it is not and cite that our culture values individual effort, individual expertise and individual originality. Add into the mix, our traditionally hierarchical organizational structures and we can find a situation that organizationally and individually promotes stove-piped thinking and stove-piped working.

One of the premier issues that must be tackled to culturally enable collaboration is the articulation and inculcation of the "WIFM" of collaboration. "WIFM," or What's In It For Me, addresses the personal value of collaboration. It will not be sufficient to address this purely at the enterprise level. The connection between collaboration and better decisions, decisions made in a more timely fashion and the ability to implement decisions quickly are advantages that will have to be spelled out for commands. Collaboration's power, the ability to enhance access to information, to decrease the redundancy of effort and to promote rapid understanding of new tasks must be expressed at the individual level. It must be presented in ways that can be related to the immediate situation. Unless commands, departments, Junior Officers, Chiefs and Sailors can see the value in collaboration, no one will do it. And, those few brave souls that might try will be restrained by their organizations that do not understand.

Armed with the value of collaboration and empowered with the means to collaborate, we can start to attack the inhibitors that remain. Lets focus on three big inhibitors to collaboration: trust, time and know-how. Chief among them is trust.

There are two principal aspects of the trust issue that need to be addressed successfully. There is the obvious one of security. Is the data and information collection, storage and dissemination – as well as the act of collaboration itself -- done in a secure fashion? Can one be confident that the data, information and knowledge being gained through collaboration are current, accurate and objectively presented?

Then there is the aspect of trusting the act of collaboration. Will sharing (rather than hoarding/parceling) one's expertise diminish one's value to the organization? Will one be criticized if they admit a lack of expertise in an area in which they seek collaboration? Will one be rebuked if a mistake is made during the highly visible act of collaborating?

Another inhibitor is time. We are all faced with challenging days. Collaboration takes time. How do we create time for collaboration in our schedules? We seem to have a relatively narrow recognition of what is considered "productive." Point papers, Power Point presentations, naval messages, correspondence – these are things we can point to, that we can count, that we can understand as being demonstrations of productive endeavors. We can trace how any one of these played in a particular decision. But we do not have the same regard for mentoring, getting training, providing teaching, professional reading, open discussions of topics, reflection or contemplation of ideas. These things we tend to regard as sidelines to what we really do. These things are often not budgeted for in one's time management calculations nor acknowledged as necessary in decision making. And yet these things are at the heart of collaboration.

The last inhibitor is know-how. Although, as stated earlier, sharing and collaboration are natural acts for humans, our culture does not necessarily foster these activities. Consequently, we have a group of professionals that do not necessarily know how to collaborate or share information. Most of us would be hard pressed to identify that which we know and know well – or to understand that which we do know is of value to someone else. How many times have you thought, “Well if I know it, everyone must know it”?

Even if we understood that something we knew might be of value to someone else, we are not sure how to go about getting that information out to others. And many of us don’t know ALL the various ways of tapping into the information and the expertise of others. Most Action Officers start with a fresh piece of paper when they get a new task. How do we teach them to start with a search instead?

Now, there are things we can do to address these cultural inhibitors. We can work toward risk management rather than stay in the confines of risk avoidance. We can establish data ownership procedures and develop authoritative data sources. We can revamp or reward and create recognition and promotion systems to enhance our appreciation of collaboration as a job requirement. We can create expertise directories, super search engines, virtual constructs in which collaboration can be facilitated and other collaboration tools. And we can develop training methodologies to help people understand how to share, what to share and how to use what they gain from sharing. Some of this can be assisted by technology. However, a great deal of it is procedural. And this will only be successful if practiced within all the Navy’s organization and throughout the naval enterprise.



Decisive Action Through Better Decisions.

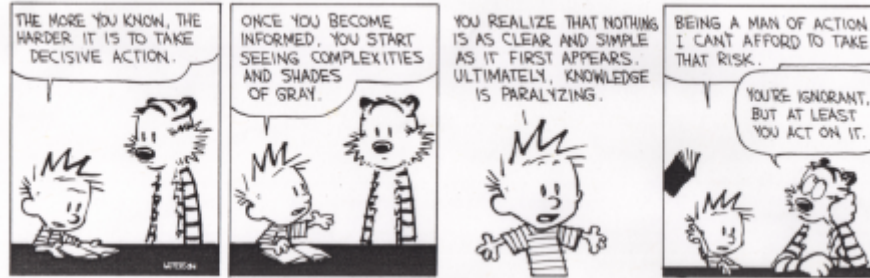

**RADM Chuck Munns
CINCPACFLT N6N8**



Enhance Cognition

To Enable the Warrior

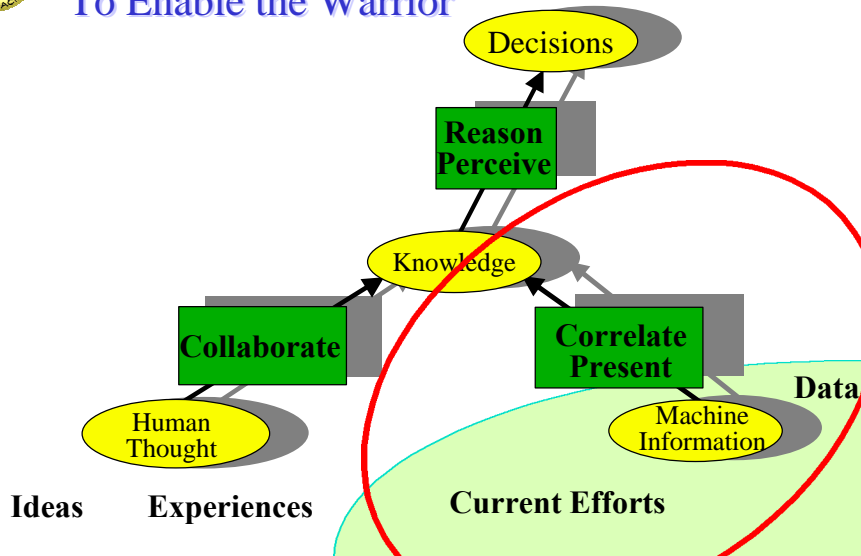



Improving the Machine Side

- Build and operate one network.
- Organize content
- Facilitate cultural change
 - network over platform
- Improve & realign Processes.

Decisive Action Through Better, Faster Decisions



Requires a Cultural & Process Change

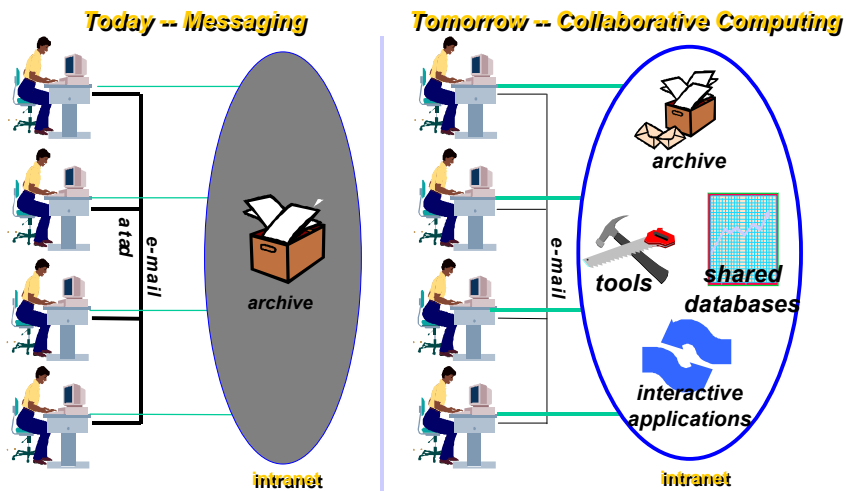

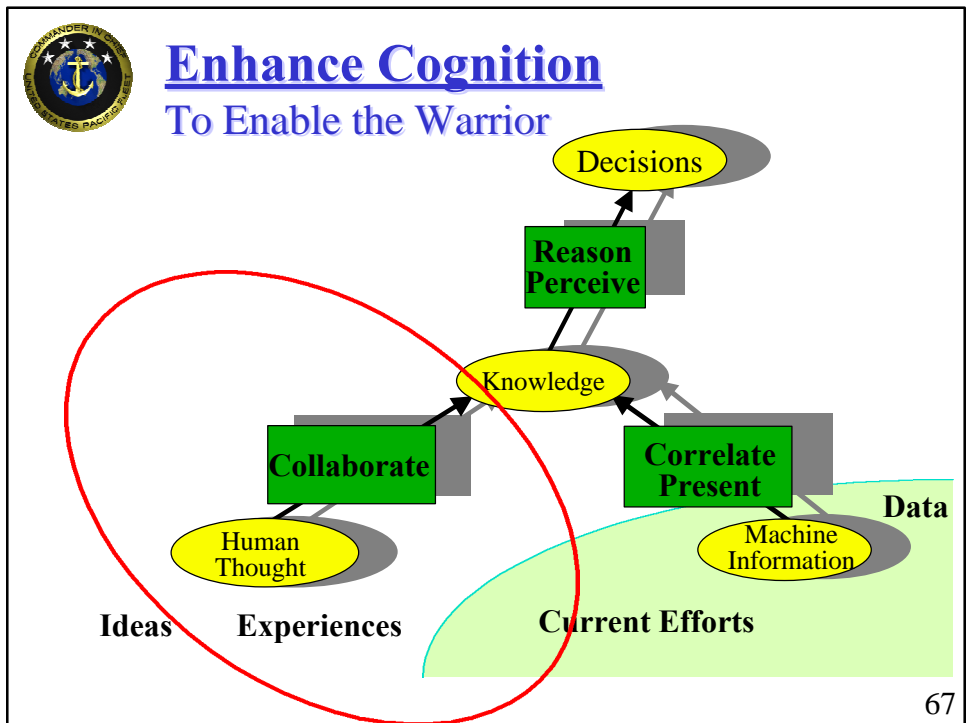
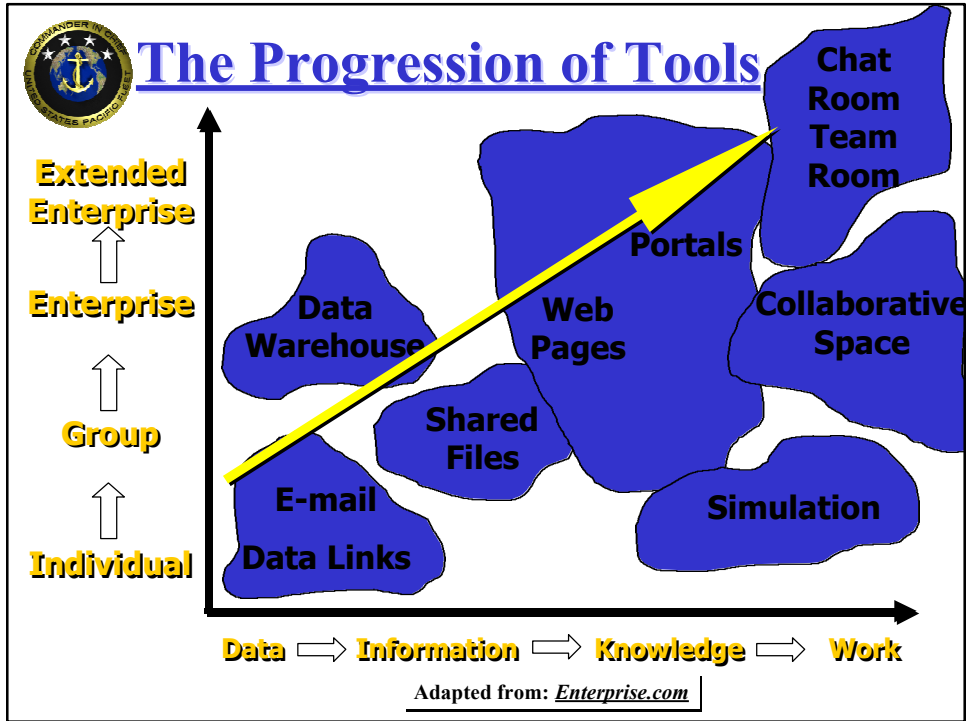



Improving Collaboration (attack the inhibitors)

- Trust
 - Incentive for Sharing
 - Security
- Time
 - Quadrant 1 vice Quadrant 2
 - Redefine “productive”
 - Not so much product based as,
 - Mentoring, training, reflection, thinking.
- Know how



Enhance Cognition To Enable the Warrior

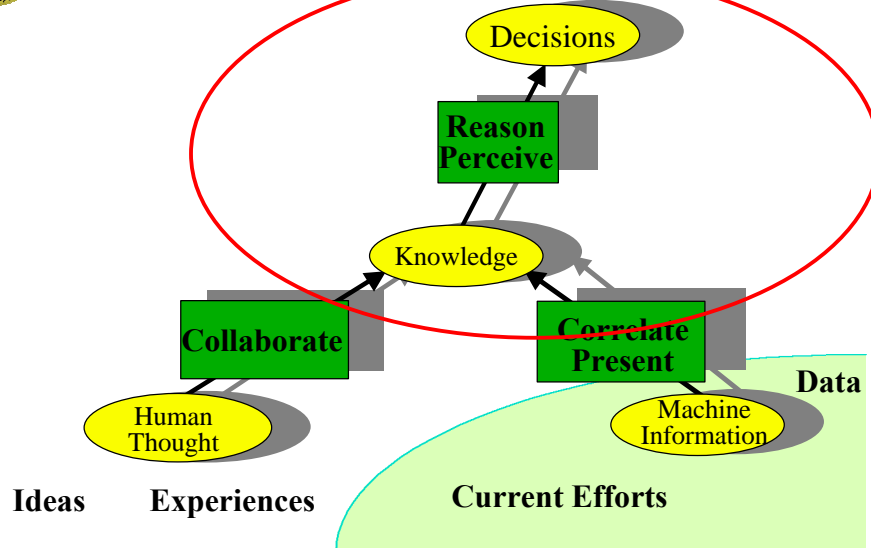



Some New Principles

- Bottom up innovation
- Information - sharing, transparency, health.
- Movement from individual to Group
 - computing, thinking, information stores
- Flattening of the organization
 - Central standards, de-central actions.
- Faster time constants.
- Monitor more, direct less.
- Decision basis - more than geographic.



The Commanders View

- Intent
- issue landscape
- logic landscape.
- chat room for pertinent issues.
- Support that reacts to my intent.
- Open the time line (lessons, forecasting)
- Team that knows what's important (info flow)



To Collaborate

Interact with national experts, the chain of command, home base and peers. Key ingredients are teamwork and a shared resource.

- Net Technologies
- Collaborative Tools
- Multimedia Conferencing

Leads to anchor desks & home echelons, creating smarter warriors, improved PERSTEMPO, higher morale & better support.



To Correlate & Present

Use Software and Computer Speed to Find New and Meaningful Relationships Among Data

- Data Mining (Data Search, Filter, Correlate, Fuse)
- Multimedia Interface, Uncertainty Representation
- Data Visualization and Anomaly Detection
- Autonomous Software Agents

Creates a smarter commander through better comprehension of enemy actions and more effective use of historical lessons.



To Perceive

Information Technologies to Reduce Data Overload
and Infuse Increased Understanding

- Computer Forecasting
- Software Agents
- Life Long Personal Digital Assistant (PDA)
- Visual Computing

Dominant warfighting through easier acquisition of knowledge, allowing more time for better decisions. Will reduce manning.



To Reason

The Warrior Making Better Decisions Through
Enhanced Cognition

- Memory Assistance & Pattern Recognition
- Battlefield Metaphors
- Complex Adaptive Systems & Genetic Algorithms

The mind and the computer evolve together. This can fundamentally change the way we train and educate.

(Intentionally blank)

(Intentionally blank)

Measuring the Human Dimension in Information Superiority

Richard E. Hayes, Ph.D.

Chief Scientist Cooperative C4ISR

Research Program (CCRP)

President, Evidence Based Research, Inc.



ONR/CADRC (Collaborative Agent Design Research Center)
Decision Support Workshop
May 2-4 2000



Measuring the Human Dimension in Information Superiority

David S. Alberts
Director
Research and Strategic Planning OASD (C3I)

Richard E. (Dick) Hayes
Chief Scientist
Cooperative C4ISR Research Program (CCRP)
President
Evidence Based Research Inc.

1595 Spring Hill Road, Suite 250
Vienna, VA 22182
Phone: (703) 893-6800
Fax: (703) 821-7742
Email: rehayes@ebrinc.com

73



Agenda



- **Key Concepts**
 - Information Superiority
 - Information vs. Awareness
- **Classic HEAT Measures of Information**
- **Command Post of the Future (CPOF) Measures of Awareness**
 - Organizing the Issue
 - Example Results from Limited Objective Experiment (LOE) 1



INFORMATION SUPERIORITY : *What is it?*



The
RIGHT
Information from Sources
to People at Time and
Place in Format. *DPG*

The capability to collect, process, and disseminate an uninterrupted flow of information while exploiting or denying an adversary's ability to do the same. *DPG and Joint Pub 3-13*



Seamless Joint
and Combined
Interoperability

Assured
Information on
Demand
Anywhere in
Real Time with
Zero Error

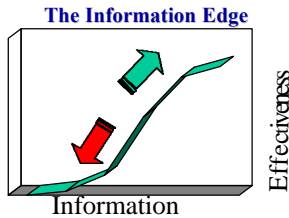

Different Perspectives,
the Same Bottom Line:
More for Us; Less for Them

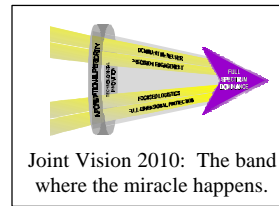



Information Superiority

A State
 achieved by establishing a
Relative Information Advantage
 from which a
Competitive Advantage
 can be gained

75

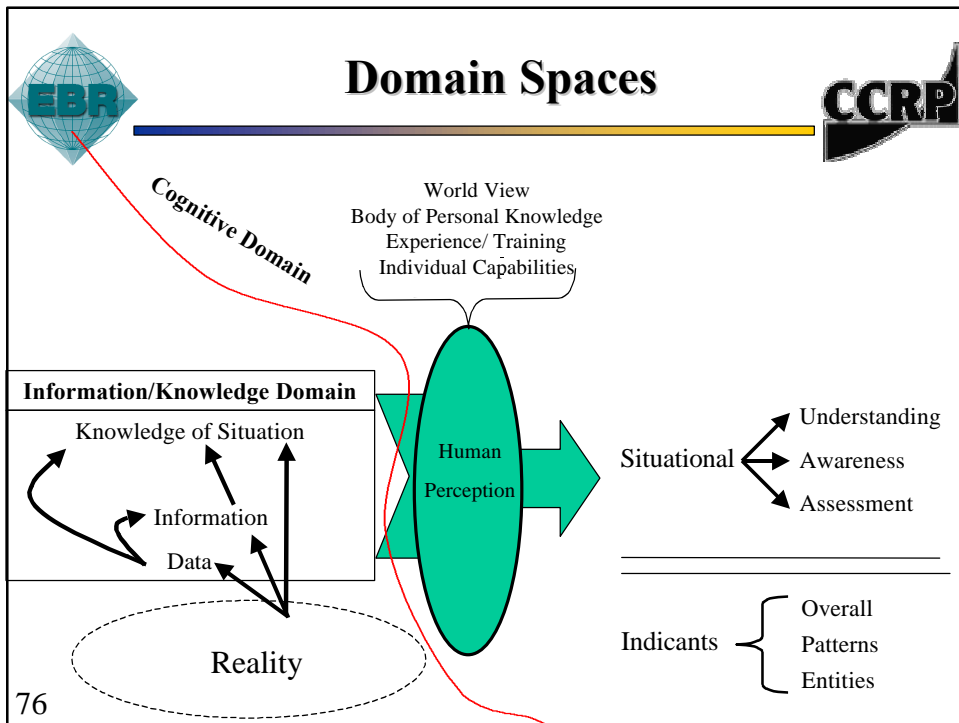
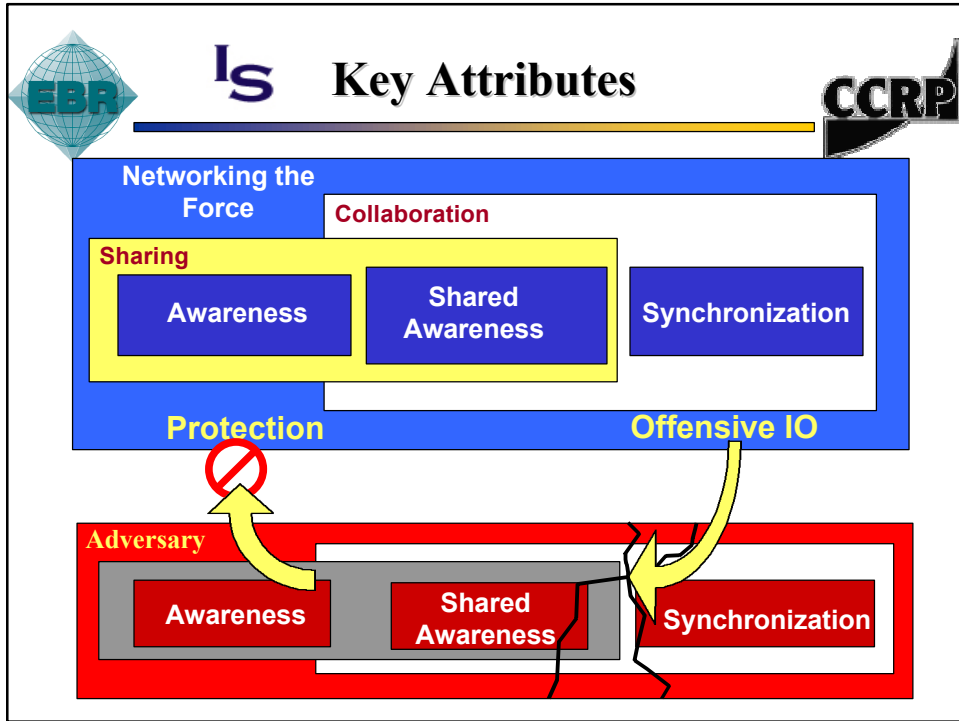



Information & Awareness



Network-intensive

People-intensive

- Battlespace Information results from the fusion of key elements that characterize the battlespace
 - Explicit Information (e.g. position of forces, geography, and weather)
 - Requires Little Interpretation
 - Can be communicated quickly and easily
- Battlespace Awareness yields predictive ability based upon interpretations based upon experience and a priori knowledge
 - Tacit Information (e.g., capability and tactics of an adversary, local customs, intent)
 - Supporting facts can be easily transferred, the underlying organizing logic can seldom be transferred quickly and easily.



“The Situation” is Patterns Between and Among



Missions and Constraints in Mission

Time
&
Space

Forces Red

– Capabilities & Intentions

Forces Blue

– Capabilities & Intentions

Other

– Capabilities & Intentions

Opportunities
&
Risks

Environment

- Physical (Terrain, Weather, etc...)
- Political, Social, Economic
- Neutrals and Innocents



What is Awareness



- Not the Information
 - Available
 - Requested
 - Provided
- But “What Sticks Between the Ears” about the situation
 - Always Perceived
 - Never Complete
 - Always incorporates the individuals’
 - ~ experience
 - ~ training
 - ~ world view
 - ~ body of personal knowledge



Headquarters Effectiveness Assessment Tool (HEAT)



HEAT is a set of consistent procedures that measure the effectiveness of a military headquarters or command center

- Quantitative, objective, and reproducible assessment of quality of C2 processes and overall effectiveness of directives
- Applied more than 50 times to exercises and real world applications in more than 200 command centers

HEAT views headquarters as analogous to an adaptive control system that influences environment through plans and directives

- Headquarters can be judged by viability of plans
 - Remain in effect for intended period
 - Include contingencies
 - Achieve assigned missions
- Diagnostic scores for quality of C2 processes

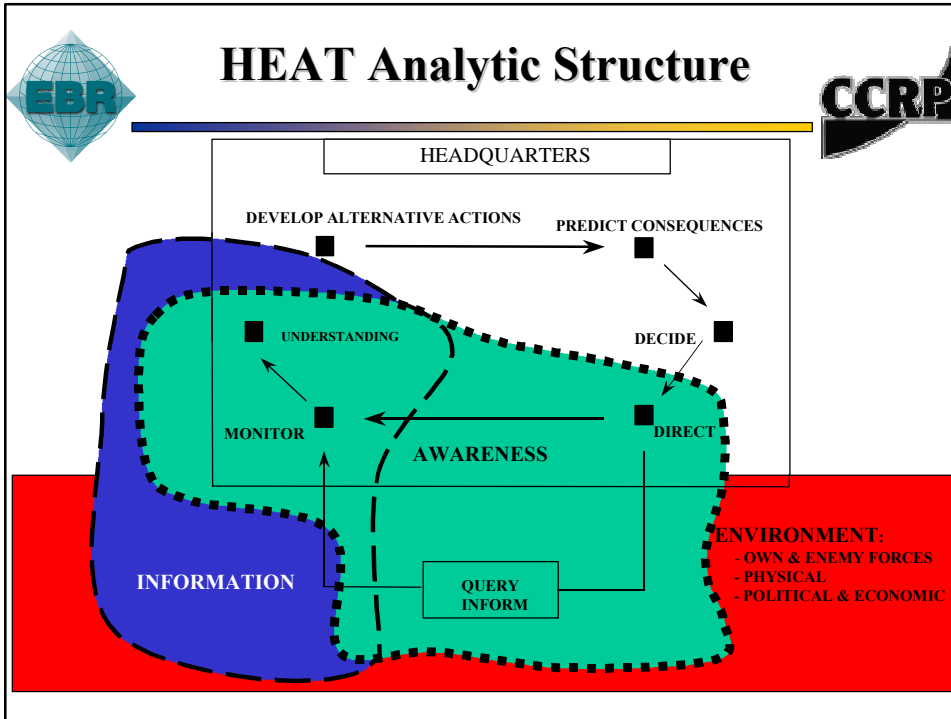

- ## HEAT Information Measures
- Completeness
 - Are all the required elements present?
 - Correctness
 - Does the information match the truth?
 - Consistency of Shared Information
 - Is the information the same across all nodes?
 - Precision
 - Was the information presented at the proper level of precision?
 - Currency (Latency)
 - How old is the information?



Command Post of the Future



Command Post of the Future (CPOF) is a DARPA program that aims to:

- Increase Speed and Quality of Command Decisions
 - Faster recognition and better understanding of changing battlefield situation
 - Faster and more complete exploration of available courses of action
- Provide More Effective Dissemination of Commands
 - COA capture for dissemination of commander's intent
 - Status and capability feedback from deployed operators
- Enable Smaller, More Mobile and Agile Command Structures
 - More mobile, distributed command element
 - Smaller support tail & reduced deployment requirements

The goal of CPOF is to shorten the commander's decision cycle to stay ahead of the adversary's ability to react.



Limited Objective Experiment - 1 (LOE -1)



Hypothesis:

- Tailored visualizations will improve Situation Awareness

MOEs:

- Correctness of Situation Awareness
- Quality of Pattern Recognition
- Level of Entity Retention

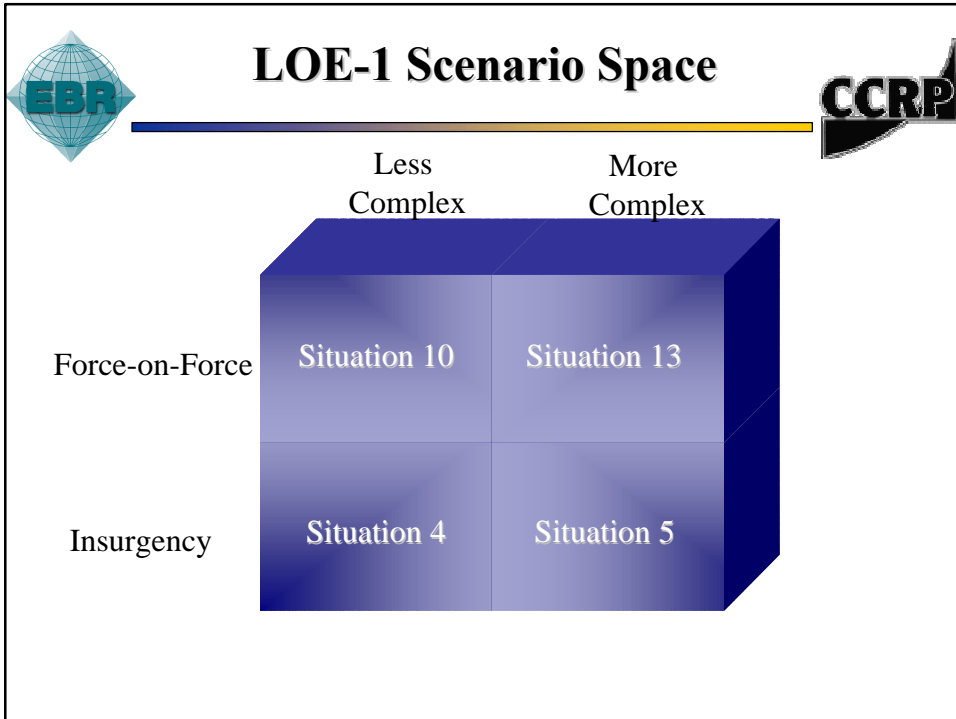

Data Collection

- 157 valid runs over 5 days (98% of design goal of 160)
- Data Collection Vehicle - Debrief Questionnaire
- Questions divided into four major elements: overall Situation Assessment, Patterns, Elements, and a Sketch of the situation
- Military experience data collected for each subject
- Run randomization compensated for variations between coders and subjects

81



Top Level Measures



- Overall Situation Awareness
 - Picture of the battlespace - enemy posture and intentions, friendly possibilities for favorable action
- Pattern Recognition
 - Dynamics of the battlespace - relative positions, strength, and capabilities
- Element Retention
 - Locations, status, events over time
- Ability to draw a general Sketch with relative positioning of important entities in space and time



“The Situation” is Patterns Between and Among

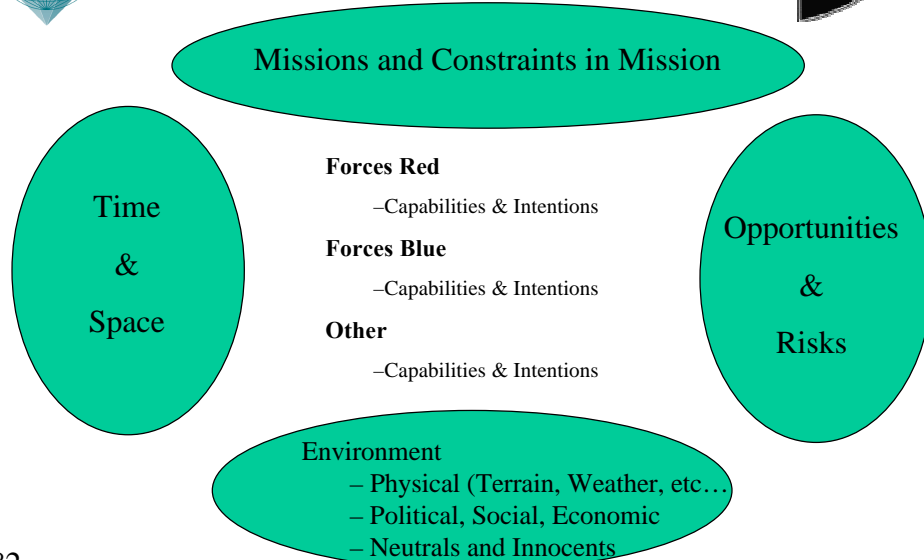

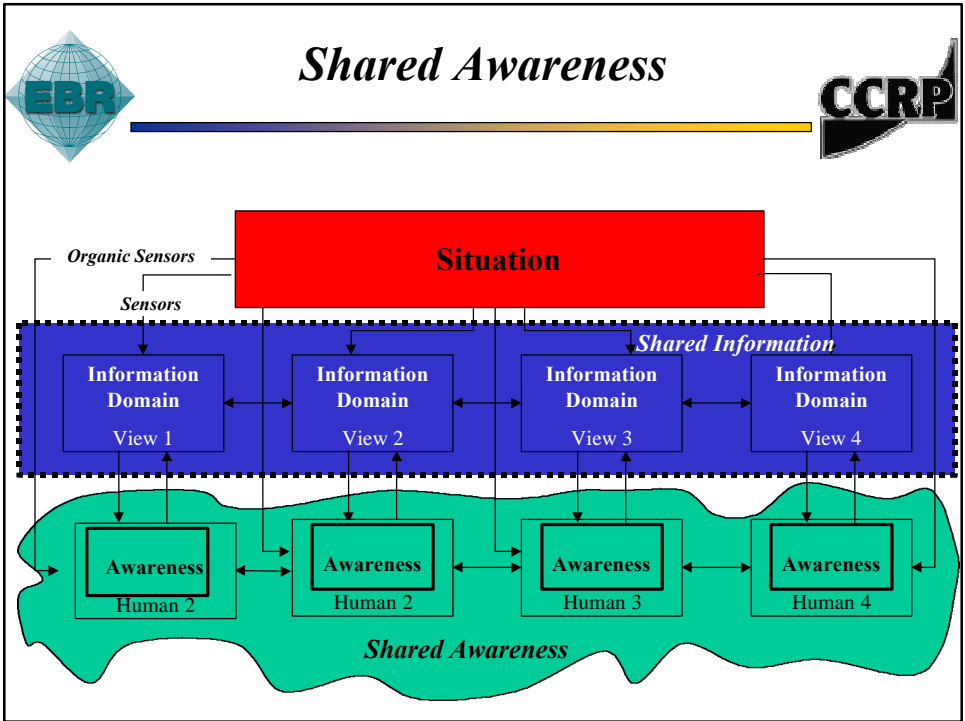

Debrief Questionnaire

1. You have three minutes to brief your commander on your assessment of the situation, what do you tell him?

83



Debrief Questionnaire (cont')



- 1a. In this situation what are the friendly:
 Opportunities?
 Risks?
- 1b What are the adversary's:
 Offensive capabilities?
 Defensive capabilities?
 Vulnerabilities?
 Intentions?
- 1c. What are the vulnerabilities for own forces?
- 2a. If you are not certain about adversary intentions and capabilities, what are the different possibilities?
 2b. If you are not certain, what information would you require to resolve this uncertainty?
 3a. What specific elements or element combinations lead you to your situation assessment?
 3b. Please make a sketch of the situation, including the specific elements or element combinations cited in your previous answer.
 3c. Was any information you would find valuable missing from the presentation of the situation?
 4. What was good and or bad about this display? What would you like to see added, removed or changed?



Metrics



	<u>Completeness</u>	<u>Correctness</u>	<u>Richness</u>
Overall			
• Prompted	% of key components	wrong inferences	added inferences
• Unprompted	% of key components	wrong inferences	added inferences
Patterns	% of pre-identified	wrong	added
Elements	% of important elements	wrong	added
Sketch	% of pre-identified elements temporal pattern geographic pattern	wrong	added



The Force-on-Force Visualization Treatments



Treatment A
Function
Color Coding

Today's Technology
Allegiance
Color Coding

Treatment B
Blobs and Allegiance
Color Coding

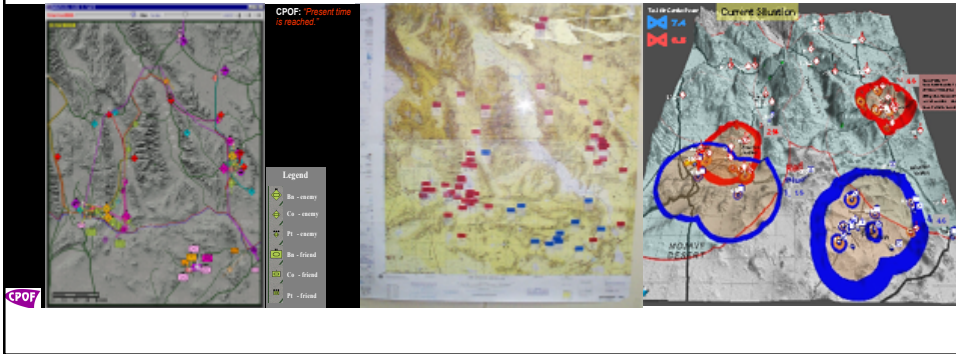

CPOF Technologies Significantly Outperform Control in Overall Scores

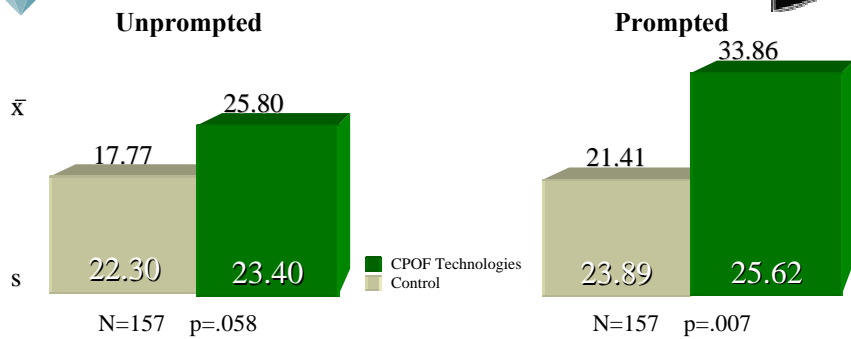

Interpretation

- CPOF Technologies Generated:
 - Better Situation Awareness (Higher Mean or X)
 - CPOF Technologies Performance Improves for Prompted

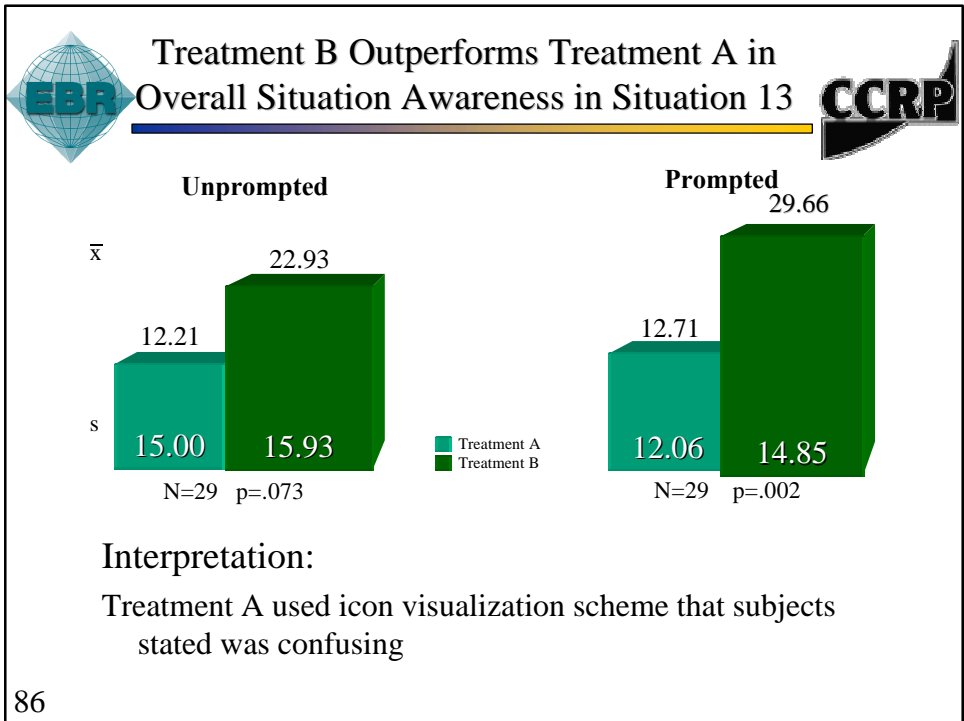
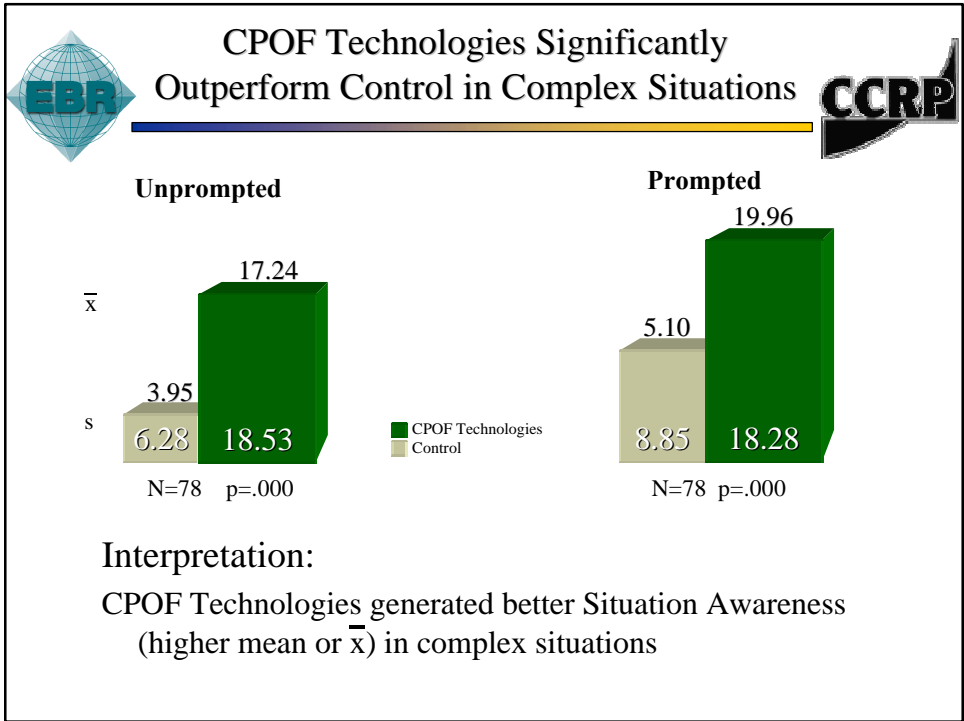



Summary



- Information does \neq awareness
- Natural layers of overall patterns and elements
 - Overall
 - Patterns
 - Elements
 - Incorrect
 - Richness
- Measures must always be developed in a military context

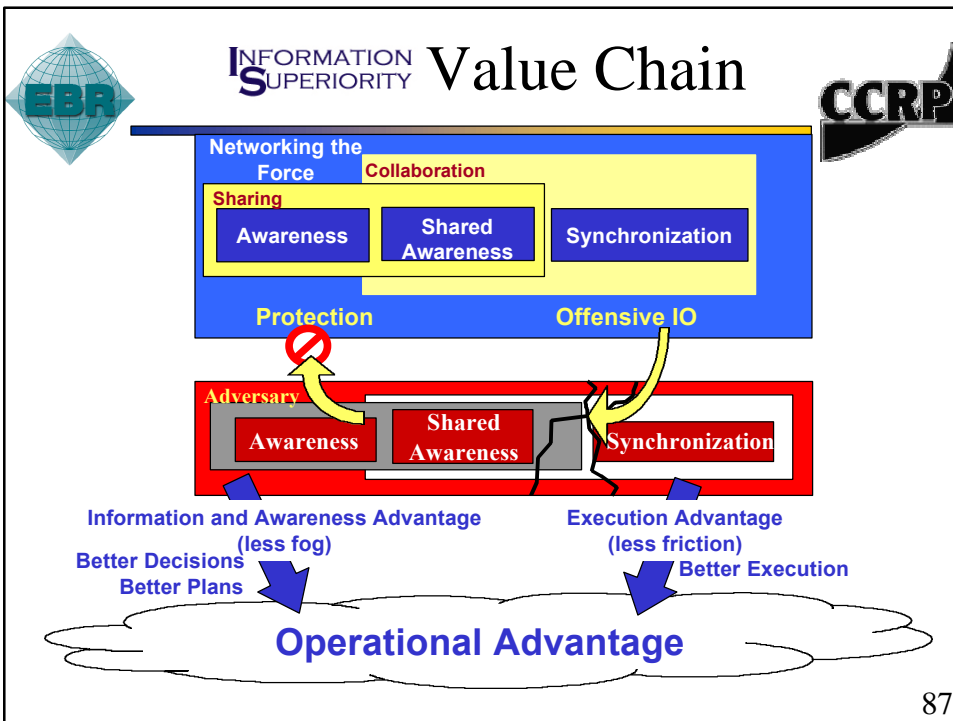



Hierarchy of ^{IS} Measures

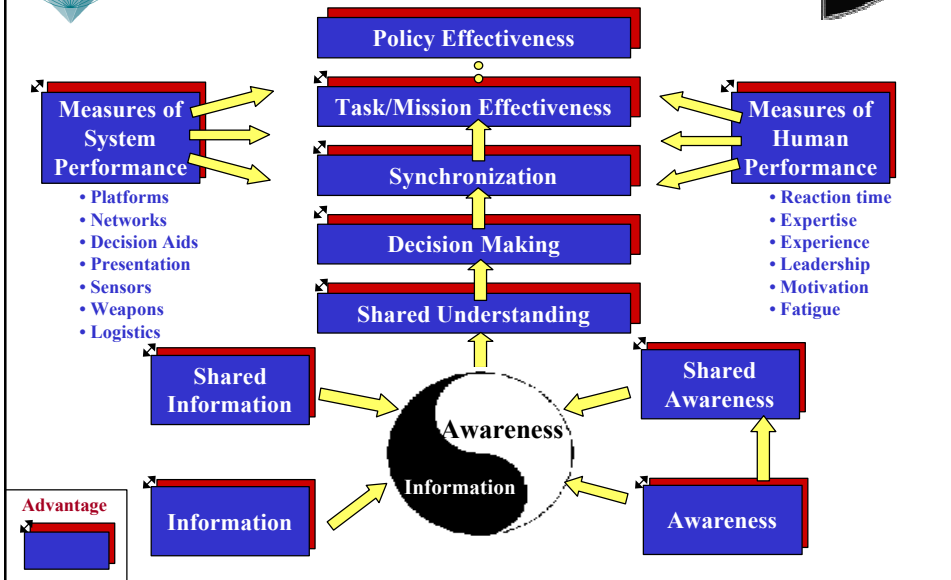

(Intentionally Blank)

Tactical Communications and Networking:

The Last Mile Challenge

Jeffrey S. Ribel
Systems Analyst
Adroit Systems, Inc.

Technology as an Enabler to Small Unit Operations

One of the first experiments conducted by the Marine Corps Warfighting Laboratory (MCWL) in 1995 set out to determine the effect of simple commercial technologies on the tactics, techniques, and procedures (TTPs) of small units conducting dispersed operations. Standard fire teams composed of four Marines were run through intense scenarios with a standard set of equipment. Then they completed the same scenarios while equipped with commercial off the shelf (COTS) equipment like cell phones and handheld Global Positioning System (GPS) devices. The results were amazing. Once the young Marines realized that the devices were easy to use and reliable, they decided to change their TTPs to incorporate these enabling technologies. They dramatically improved their operational efficiency and effectiveness within the scope of each scenario. They were able to split into smaller teams since they now had reliable mobile communications. They had a large piece of enhanced situation awareness (SA), since they knew their own position location information along with that of their adjacent and subordinate units. Given the resources and the mandate, these young Marines displayed initiative and innovative thinking that reaffirmed the validity of the Marine Corps Warfighting Laboratory's theory that concept-based experimentation is the best approach to properly integrate information technology with Marine Corps tactics, techniques and procedures.

This is just one example of how the explosion of information technology (IT) can revolutionize military, government, and civilian organizations individually and collectively. Conversely, there is still a paradox since every IT solution we innovate uncovers more questions and issues, and increases our reliance on the very same technologies that solved the initial problem. One such dilemma is how do we enable warfighters and first responders with enhanced situation awareness and a communications and network architecture to support such capabilities? The answer is in the above example. We must field 80% solutions to operating forces and organizations in small increments to experiment with the new capabilities in that environment. How do we take this one step farther? We give them training, equipment, and ongoing support for required decision support tools. The paradox lies in the fact that these capabilities require appropriate communications and network connectivity across all levels of the organization. The major challenge is to bridge the current gap between the upper and middle levels down to the end users out in the field. These end users are considered "disadvantaged" because that gap currently poses challenges not seen in providing connectivity for command posts and larger facilities.

These end users – often small military teams, first responders, and others out in the field – must have interoperability, flexibility, responsiveness, mobility, discipline, survivability, and sustainability, all characteristics that support -- not hinder -- mission accomplishment. Herein lies the challenge of “the last mile.”

Unfortunately, there is no one solution that fits all last mile requirements. I would love to stand here and say, “Ladies and gentlemen, I have analyzed your organizations’ diverse last mile requirements, and I proudly present to you the panacea for your ills: Wireless Local Area Network (LAN).” Our problem is not this simple. If it were I would not be standing before you as a Systems Analyst, I would be the Chief Technology Officer or Chief Executive Officer of a global communications and networking powerhouse! Rather, we will identify the boundaries of the last mile problem, scope the requirements for a solution, and later discuss in open forum potential technologies and products that should be in our toolbox of solutions. This is rightfully so, since innovation and integration require education, training and personnel equally as much as the enabling technologies.

A Focus on Information Superiority

To set the stage for today’s operational environment, let us briefly discuss the military point of view. General Gordon Sullivan, former Army Chief of Staff, states that “Information is the currency of victory on the battlefield.” (JP 3-13 1998) Furthermore, Joint Publication 3-13 says

“Rapidly advancing information-based technologies and an increasingly competitive global environment have thrust information into the center stage in society, government, and warfare in the 21st Century. Information and information based technologies are pervasive and impact every facet of warfighting...” (JP 3-13 1998)

This quote directly addresses the information and IT-based nature of our command and control systems and current operations.

Joint Publication 1-02 (2000) defines a command and control system as “the facilities, equipment, communications, procedures, and personnel essential to a commander for planning, directing, and controlling operations of assigned forces pursuant to the missions assigned.” We refer to each of these components as vital parts of command and control. There is no value in trying to determine which component is most important. Without being too cliché, we see that the whole is definitely the sum of its parts. The value of the command and control system is highly dependent on the quality of the components that comprise the system. To use the military example again, we can engineer and improve parts of the system to the nth degree, but without communications the system crumbles, and without some level of decision support, there is very little value to the mission-oriented commander. In relation to decision support, information technology and communications are pillars in the foundation of any command and control system designed to implement and support such a worthwhile endeavor.

Why is Decision Support a Worthwhile Endeavor?

Command and control warfare is based on protecting our information and information technologies, while attempting to interrupt the enemy's ability to do the same. Many current forms of unconventional and unrestricted warfare revolve around our ability to destroy the enemy's will to fight by affecting their command and control systems and delaying or preventing decision-making. Conversely, decision support tools allow us to filter out irrelevant information and pinpoint specific bits of knowledge that speed our ability to make important decisions. The Marine Corps Warfighting Laboratory's dynamic decision-making hypothesis states that,

“One of the characteristics of the 21st Century battlefield is...a more rapid operational tempo coupled with larger quantities of information more rapidly available to commanders. Hence, success will depend to a greater extent on their ability to make faster and better decisions at all levels of command.” (MCWL 2000)

Joint Pub 6-02 (1996) states that command, control, communications, and computer (C4) infrastructures must “Provide decision support for maneuver, targeting, fire support, intelligence, air operations, logistics, and information warfare.” Decision support is inextricably tied not only to successful military operations, but also to government and industry operations. In today's IT-based environment, commanders and leaders could easily drown in irrelevant information, which would incapacitate their decision-making ability and thwart any attempt to bring order to the massive flow of information into an organization's command facility. Decision support tools like the Integrated Marine Multi-Agent Command and Control system (IMMACCS) and SEAWAY enable:

- Enhanced situation awareness (SA) through a common, adaptable, scalable, and tailored view of the environment
- High level internal representation of characteristics of (and relationships between) real world objects in the environment
- Structured decision support via agent-based reasoning applied to the above objects, relationships, and environment
- Event alerts specified by user parameters
- Interface and data sharing with legacy systems, and
- Human-computer partnership based on the strengths of each partner

Decision support systems have commercial promise as well. For example, early internet search engines were based on indexing by keyword and presented much more irrelevant information than the latest search engines that incorporate some sort of agent based reasoning. A search for “CDM” in the Excite search engine (<http://www.excite.com>), may produce a link to the CDM Technologies website, but also to the Church of Divine Man & CDM Psychic Institute! The search algorithm has no way to determine which CDM meets the search request, so it presents both possibilities, and thousands of others as well. A search at Ask Jeeves (<http://www.askjeeves.com>), which uses a natural language parsing agent, allows queries in the form of a question, such as “What is the URL for CDM Technologies?” This Query returns potential answers based on the context of the question and arranged by each relevant word in the

query. Ask Jeeves also presents an aggregated group of relevant hits from various other search engine sites on a single screen in drop down selection boxes. This is no silver bullet for the information consumer, but as search engines incorporate lower level decision support related technologies, they enable relevant and timely information flow to website visitors who will return and continue to use the tools that provide valuable results.

Many Fortune 500 companies warehouse functional area data by storing it in databases from companies like Oracle, Informix, and Microsoft. The companies mine this data using query tools supplied by companies like MicroStrategy. Imagine the power of a decision support front end for these query tools. Agents could mine an object-oriented database (OODB) of millions of objects to create and establish relationships between them. In the area of networking, Lockheed Martin has created just such a tool. This tool uses agents to examine a database of information composed of event logs, network traffic, network activity, email, and other services. The query agent sorts the information and permits screening of network activity by keyword, user, service, and combinations of each. The applications of this tool range from business intelligence to corporate network misuse detection to information warfare.

The above examples of decision support in action derive their value from the ability to access relevant information via the networks and communications that connect each node on the network. In the case of a local area network (LAN), if connectivity is lost between nodes there is no decision support, unless information is cached locally and used in a latent manner. Metcalf's Law states that the value of a network increases by the square of the number of nodes on that network. Communications and networking over the last mile is critical to an organization's ability to provide decision support and information flow between different levels in the hierarchy.

Recent Paradigm Shifts That Favor Technical Solutions

Humans naturally strive to increase productivity, as proven by recent attempts to leverage the benefits of information technology at all costs. Occasionally, paradigm shifts like this occur that lead to organizational change and societal progression (or regression). Convergence in time of recent shifts has led to "Revolutions in [Every Category]." The following paradigm shifts are particularly relevant to the challenges associated with last mile connectivity.

The Nintendo Generation. Moore's Law states that computer processing power doubles every 18 months. He stated this theory in the late 1960s. Today, the law still applies, and we have children from multiple generations that grew up familiar with that processing power, and covet it in everyday life. These children use that increasing processing power and personal experience to continue the innovation cycle as they move into the military, government, and civilian workforce. This experience is vitally important to proper training and the resultant lifecycle of technology.

Shift in Research and Development Spending. As consumer demand for information technology grew, research and development (R&D) by industry grew while overall military budgets shrank, along with that portion allocated to research and development. The Department

of Defense has a long history of innovative developments like the original internet and satellite communications. In recent past, industry has far surpassed military capability to innovate. The military and government agencies must take advantage of commercial off the shelf (COTS) product development to enable our organizations and personnel to get the job done, just like industry enables consumers today.

Some antagonists would argue that we are too dependent on industry to provide technology to the masses. The following quote has a negative connotation, but certainly has the ring of truth based on historical precedent.

“Technology is like ‘magic shoes’ on the feet of mankind, and after the spring has been wound tightly by commercial interests, people can only dance along with the shoes, whirling rapidly in time to the beat that they set.” (Liang and Xiangsui 1999)

Interestingly enough, it comes from the book “Unrestricted Warfare” by two People’s Liberation Army senior colonels, Qiao Liang and Wang Xiangsui.

The Wired World. *Wired* magazine does not derive its name from the copper and fiber - optic cables that circle the globe today. The term “wired” has become synonymous with seamless, always-on connectivity often implemented with wireless and broadband technologies. Unlike the origins of wireless radio frequency (RF) technology developed for the military, wireless today has a distinctly commercial connotation, often associated with standards-based, open networks like TCP/IP and other types of internet connectivity.

The Value is in the Network. Commercial emphasis used to lie in providing a product or service. Many companies and investment professionals now recognize that Metcalf’s Law shows that value often lies in your network, not in the single node. The collective power of the consumer base is one example. Internet Service Providers and many other internet based businesses already (or will soon) offer free products and/or services while making money by mining the collective value of their consumer base. The long-term viability of this business model has yet to stand the test of time, but we already see companies commoditizing technology products like cell phones and personal computers to create a valuable and sizable client base as a profit center.

Mesh Network Topologies can Flatten Hierarchical Organizations. Many organizations reap the benefits of decentralized command and coordination today. When smaller and smaller teams become networked, the network’s value increases for the sponsoring organization. By pushing connectivity down to lower levels, we enable decision-makers on scene if they have access to useful tools via the network. Of course, the end user knowledge of “commander’s intent” and the procedures behind the technology directly impact the organization’s ability to successfully flatten their structure.

The Strategic Corporal. As we push information and delegate responsibility down the organizational chain, we also increase the requirement for proper education, training, experience, and ultimately mission success. Recently there has been an increased emphasis on small unit operations. What used to be tactical implications on outcome quickly become strategic in nature

when we empower smaller, task-organized units with the mandate to perform and the right decision support tools. Connectivity to these lower levels becomes increasingly important, and we note that due to the change in perspective and focus, what we commonly call “the last mile” is really “the first mile.” This paradigm shift will help focus our collective attention and assets on the problem at hand – appropriate “tactical” communications and networking.

Miniaturization as an Enabler. The transformation from an analog to a digital world and breakthroughs in signal processing and computing have proven that miniaturization drives innovative new products and services never before considered possible. In about fifty years, state of the art has gone from a computer called ENIAC that literally filled rooms with vacuum tubes to a matchbox-sized web server that fits in a shirt pocket; from transistors to Application Specific Integrated Circuits (ASICs) and Digital Signal Processors (DSPs); from systems to systems on a chip that allow alphanumeric pagers, and soon cell phones, in a wrist watch form factor.

As if a testament to the power of the information technology paradox, the following quote addresses computing speed,

"...With the advent of everyday use of elaborate calculations, speed has become paramount to such a high degree that there is no machine on the market today capable of satisfying the full demand of modern computational methods. The most advanced machines have greatly reduced the time required for arriving at solutions to problems, which might have required months or days by older procedures. This advance, however, is not adequate for many problems encountered in modern scientific work and the present invention is intended to reduce to seconds such lengthy computations..." (ENIAC Patent, 1947)

This observation has stood the test of time. The source is the ENIAC patent filed on June 26, 1947.

Challenges of the First Mile

Joint Publication 6-0 states that C4 systems must be interoperable, flexible, responsive, mobile, disciplined, survivable, and sustainable. (JP 6-0 1995) These characteristics all apply to connectivity over the first mile, especially when providing tools like decision support to dispersed personnel.

Interoperability is key to the success of military, government, and industry system design and implementation. Assets and resources are wasted if we do not design for interoperability throughout each stage in the system lifecycle. Due to previous investment and different technical requirements and approaches, most solutions will comprise a system of systems, each interoperable or compatible, and modified for use as a collaborative system. The days of creating stovepipe or proprietary system are gone, unless there is a compelling fiscal, security or technical requirement for the system. Eventually, older legacy and stovepipe systems will disappear as they become unsustainable for fiscal and maintenance reasons. Open systems and standards will become the norm due to commercial investment.

Flexibility includes the ability to employ a system across each possible organizational scenario without extensive system reconfiguration or degradation. Systems must be scalable and adaptable for differing operational requirements and environments. Flexible systems provide the services required without major impact on the end users or communications and network planners.

Responsiveness calls for appropriate reliability, quality of service, and availability across the system at various levels throughout the organization. Systems must be timely and redundant if necessary. Timeliness means speed. Latency will destroy a network's ability to support real time applications and decision support tools. Redundancy can be achieved through alternate paths or duplicate (backup) equipment, and graceful restoration of service(s) following an outage.

Mobility is characterized by small, portable or handheld system components that easily facilitate regular and continuous movement. Systems at the end user level should not inhibit the operational tactics or required information flow to and from each organizational node. Mobility is ideally characterized by systems that require little or no ground-based infrastructure for small units. Wired and cabled systems are often not mobile. Individuals and units need to seamlessly roam throughout the operating area without extensive reconfiguration or regular reissue of equipment.

Discipline should be inherent to the system and the organizations employing the system in an operational environment. Discipline includes physical and procedural management and systems control functions, security, and prioritization of information flow.

Survivability entails system security, including physical, cryptologic, operational, and procedural protection. The system must be robust enough to provide the services required in extreme environments without susceptibility to jamming, intrusion, deception, or interference. Security is absolutely vital. In the military operational environment, any lack of ability to protect your information and systems is a showstopper.

Sustainability includes maintainability for extended periods, and self-supporting operations for shorter periods of time. A sustainable system should also continue to operate locally if wide area connectivity is lost.

How Much Bandwidth is Necessary?

Bandwidth is a favorite communications and networking topic. As a Marine Corps Basic Communications Officer Course (BCOC) student in 1992, our class motto was "It's all about bandwidth, baby." This concept is reinforced by an unidentified source that once said as quickly as bandwidth becomes available, it would be saturated by applications and systems that do not necessarily exist or are not supported today. This reflects the rapidly changing IT environment and our ability to quickly fill the dark fiber that has already been laid. I have repeatedly seen briefing slides from high levels in the Department of Defense that estimate military component

and Joint Task Force (JTF) bandwidth requirements. With every brief, the estimates increased dramatically, from hundreds of kilobits per second for each service, to greater and greater orders of magnitude. Every organization must determine its own bandwidth requirements based on operational need and focus of effort and resources.

A good example of this trend to fill available bandwidth is our use of Microsoft PowerPoint in the conference rooms of America. Militarily, the Secretary of Defense and the Chairman, Joint Chiefs of Staff recently ordered briefers to abandon slick graphics and avoid glitzy slide transitions and sound effects while focusing only on substantive briefing material. Commercially, the San Jose Mercury News recently published an interview with the CEO of SUN Microsystems, Scott McNealy. Mr. McNealy pointed out that he discovered their corporate network contained 12.9 gigabytes of PowerPoint slides that required untold man-hours to research, compile, jazz up, brief, and maintain. He banned the use of PowerPoint and noted that since his decision, SUN has posted three straight quarters of record profits due to their employees' return to substantive work. Despite his ongoing operating system battle with Microsoft and his obviously biased personal opinion, Mr. McNealy has a valid point. We must focus on providing the most relevant information in a timely manner to the right people at the right place at the right time. This renewed focus dictates an appropriate mix of communications for decision support and the optimum level of interaction between the computer (hardware and software) and its human operator.

The Human-Computer Partnership

Figure 1 depicts the Cognitive Hierarchy as outlined in Joint Publication 6-0 (1995). Although a simple concept, the Cognitive Hierarchy sets the framework within which communications, decision support, and computer hardware and software must interact. Human and computer processing is applied to data, which turns into information. Human cognition is applied to information, which turns into knowledge. Human judgment is applied to knowledge, which turns into understanding. In turn, understanding enables human decision-making with computer assistance. Communications provide the transport mechanism between each of the various levels in the cognitive hierarchy. As stated by Chapman, Wood and Pohl, "while the computer can retrieve and send information from and to shared databases, it exercises these capabilities only on the request of its user. Collaboration within the problem team is largely restricted to the communications initiated by team members." (Chapman et al. 2000) CDM Technologies and Cal Poly have been very careful to develop collaborative decision support systems that use the strengths of the human and computer partners, rather than just automating human manual processes. In fact, they note that human and computer capabilities are complimentary. "Human capabilities are particularly strong in areas such as communication, symbolic reasoning, conceptualization, learning, and intuition...Computer capabilities are strongest in the areas of parallelism, speed and accuracy." (Chapman et al. 2000)

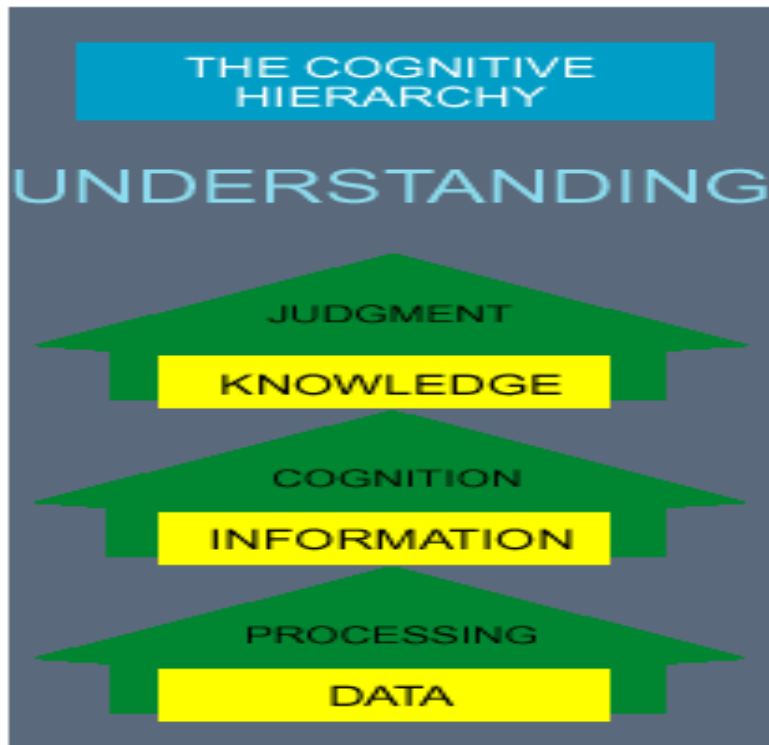

Figure 1. The Cognitive Hierarchy

The Marine Corps Warfighting Laboratory has embraced the human-computer partnership, to the degree that it is virtually inseparable from their Five Year Experimentation Plan. Through an iterative process of research, development, experimentation, refinement, and exploitation, they strive to find the best fit within the Marine Corps for various information-related enabling technologies. Throughout this process, all data collected is captured for the record and later scrutinized to determine the successes and failures ascribed to certain systems and technologies. Along the way, tactics, techniques and procedures are developed, modified, and disseminated as lessons learned to the Fleet Marine Force.

I urge you to follow the example set by the Marine Corps. Commit resources to study your organization's special operational requirements and bandwidth needs. Along the way, educate your employees on the potential efficiencies and new capabilities possible within an IT-enabled organization. Incite technical and procedural innovation and infuse your organization with the pride that evolves from overcoming the challenges posed by the evolving operational environment.

Summary

In conclusion, the military, government, and industry must join together to research and develop affordable communications and networking systems that use efficient protocols and

pervasive standards and promote interoperability, flexibility, responsiveness, mobility, discipline, survivability, and sustainability for operating forces at the lowest appropriate levels of our organizations. We must band together to garner industry and government sponsorship of important efforts like the National Institute for Urban Search and Rescue's (NIUSR) Extreme Information Infrastructure (XII) effort led by Lois Clark McCoy. We must send our technicians, engineers, and programmers out into the field with operating forces to learn the constraints and restraints of the environments in which our organizations work, and for which they are developing solutions. A renewed focus on reducing and overcoming the challenges of the first mile will both enable future two-way information flow for decision support and ensure that decision support is available in near-real time to those that can benefit the most – the personnel on scene in the “heat of the moment.”

References

Joint Publication 3-13 (1998), Joint Doctrine for Information Operations, (pp. II-1).

Joint Publication 3-13 (1998), Joint Doctrine for Information Operations, (pp. I-18).

Joint Publication 1-02 (2000), Department of Defense Dictionary of Military and Associated Terms, (pp. 89).

Marine Corps Warfighting Laboratory (2000), Commercial Off the Shelf (COTS) Strategic Planning War Game II brief, (pp. 5).

Joint Publication 6-02 (1996), Joint Doctrine for Employment of Operational/Tactical Command, Control, Communications, Computer (C4) Systems, (pp. II-1).

Q. Liang, W. Xiangsui (1999), Unrestricted Warfare, (pp. 7).

ENIAC Patent (1947), No. 3, 120,606.

Joint Publication 6-0 (1995), Doctrine for Command, Control, Communications, and Computer Support to Joint Operations, (pp. II-4).

Joint Publication 6-0 (1995), Doctrine for Command, Control, Communications, and Computer Support to Joint Operations, (pp. I-4).

Chapman, A.J., Wood, A.A., Pohl, J. (2000), Collaborative Decision-Support in the XII Environment, NIUSR Decision-Support Position Paper, (pp. 13).

Chapman, A.J., Wood, A.A., Pohl, J. (2000), Collaborative Decision-Support in the XII Environment, NIUSR Decision-Support Position Paper, (pp. 11).

Information Representation Basis of Decision Support Systems

Russell Leighton
CAD Research Center, Cal Poly, San Luis Obispo, California

Introduction

The software industry (and to great extent the computer industry as a whole) is undergoing radical change with respect to information exchange and management. It is recognized that with the tremendous increase in the flow of information, brought about by the advent of the global Internet, that management of this flood has become a primary issue. Even from an individual perspective managing daily information-flow consumes a large fraction of our productive time. Worse yet, we can expect that the flow rate will increase with time. Additionally, issues regarding the exchange of information are becoming industry-wide concerns as indicated by the increasing interest in distributed systems and common data exchange formats. It is recognized that we can no longer afford development of distributed systems using incompatible data exchange schemes. It is also becoming more evident that passing around unintelligent (flat) data restricts the ability to filter information and/or imposes large resource penalties to adequately interpret the data. Hence, even with the limited application of decision support in current systems, future information processing systems are going to rely heavily on decision support to manage the flood. By building systems, or even complete operating environments, that utilize intelligent information representation the addition of decision support becomes a natural fit.

The focus of this paper will be to discuss the use of ontological models as the basis for representing information in decision support systems. After a brief explanation of what an Ontological model is, discussions of why ontological models might be used, how to go about developing a model, some limitations of ontological models, and the possibilities for extension will follow.

What Is an Ontological Model?

The representation of data and its interpretation for decision support systems by necessity must be complex due to the very nature of the decision support process. Either this complexity may be defined in the interpretation of the data or it may be placed in the data representation itself. By placing the complexity in the data representation, less work would need to be performed to interpret the data. Additionally, this complex representation may more accurately reflect the real nature of the problem we are trying to analyze and may in fact more directly represent the knowledge that we are trying to capture. It could be further argued that as we move this complexity into the representation we are moving more towards a true information representation and away from the less complex data representation.

Complex information representation may be best described using an Ontological Model. The definition of an Ontological Model could be defined based on the notion of an Ontology. The dictionary definition of Ontology is "a particular theory about the nature of being or the kinds of

existents" which is rather open-ended and subject to interpretation. We could describe an Ontological Model more specifically as "a model describing kinds of objects based on characteristics, relationships, and behavior."

The descriptive features of an object are described by its characteristics. A typical flat data representation would consist solely of these characteristics. However, "real world" objects are characterized not by just their outward features but also by their relationships - the roles that they play with respect to other objects. For example, a door can be described by its dimensions, color, etc. However, by recognizing that the door also serves the role of an opening between connecting rooms we can infer additional information. Furthermore, relationships themselves may have characteristics that could constrain roles. A constraint, for example, could be defined restricting the role of a room-opening to that of a door (or possibly a window). A strictly relational data representation would include relationships (roles as keys to foreign tables) but with no logical constraints.

In addition to its features and relationships an object can be further characterized by its behavior - e.g. how the object responds or acts based on some internal or external stimulus. Behavior could be, for example, simply the derivation of a feature based on other characteristics. If the dependant characteristics change then the feature would be updated as defined by the object's behavior. In a simple data representation all behaviors must be inferred and would therefore be subject to the particular perspective of the interpreting entity. In some situations, this inference of behavior makes sense because the outcome may be dependent on the environment in which reasoning occurs (such as with a software agent or human being providing decision support). However, if this behavior is inherent in the logic of the object and is intended to represent a common response then it makes sense to implement the behavior in the object rather than require that all interpreting entities implement the same logic.

Why Use an Ontological Model?

The basis of object-oriented representation is firmly rooted in "real world" concepts and the way that human beings perceive their environment, therefore, a natural use of an ontological model would be to represent "real world" objects. Systems employing expert knowledge therefore benefit greatly from such a natural representation of the domain upon which they reason on. Additionally, Ontological models may be utilized throughout the system development process. As the software industry moves increasingly towards use of object-oriented programming languages the use of an Ontological model for application design is becoming commonplace. Furthermore, development of decision support systems requires some form of a knowledge acquisition process to enable capture of expertise. An ontological model could be used to aid in this process.

Through development of ontological models, a natural artifact is documentation. The use of standard methodologies provides a common modeling language, which if used to formulate models can supplement documentation for a software development project.

Knowledge Acquisition

The task of acquiring the knowledge needed to build a specialized application requires the capture of expertise. Even with access to subject area experts and raw information, organizing and formulating an accurate picture can be a difficult problem. Methodologies used to build ontological models have been developed to closely mimic information organization in a way that is natural to human understanding. Therefore, knowledge tends to translate well into an ontological representation built using these methodologies. Additionally, the modeling process and subsequent model analysis suggest questions that help to further refine and correct model deficiencies and inconsistencies. The questions that arise from the model analysis directly reflect the knowledge contained in the model in content.

Information Representation

The use of an ontological model, to represent information, provides a rich description of the knowledge domain. The model ultimately used by the system may very well be directly derived from the model built during knowledge acquisition.

In a flat representation, characteristics are defined to describe the data. Relationships may be defined as characteristics that simply refer to other data items. However, such references are not constrained and as such could be defined outside of any logical role, therefore, checks must be made to insure that the reference makes sense. Additionally, any behavior associated with particular data must be inferred through its characteristics. Both the reference checking and the behavior inference must be performed outside of the representation and is therefore subject to varying interpretations. By incorporating both relationships, constrained by logical roles, and behavior into the information representation a great deal of the complexity involved in reference checking and behavior inference is removed from the external application. In addition, if a model was developed as part of the knowledge acquisition process it may be possible to directly use this model as the basis for information representation in the developed system.

Floor Layout

As a simple example, consider the following floor layout. We could represent the parts that make up a floor-layout as a collection of data. For example, we have rooms that have a location and size, windows and doors with dimensions, and some lights.

Floor Layout

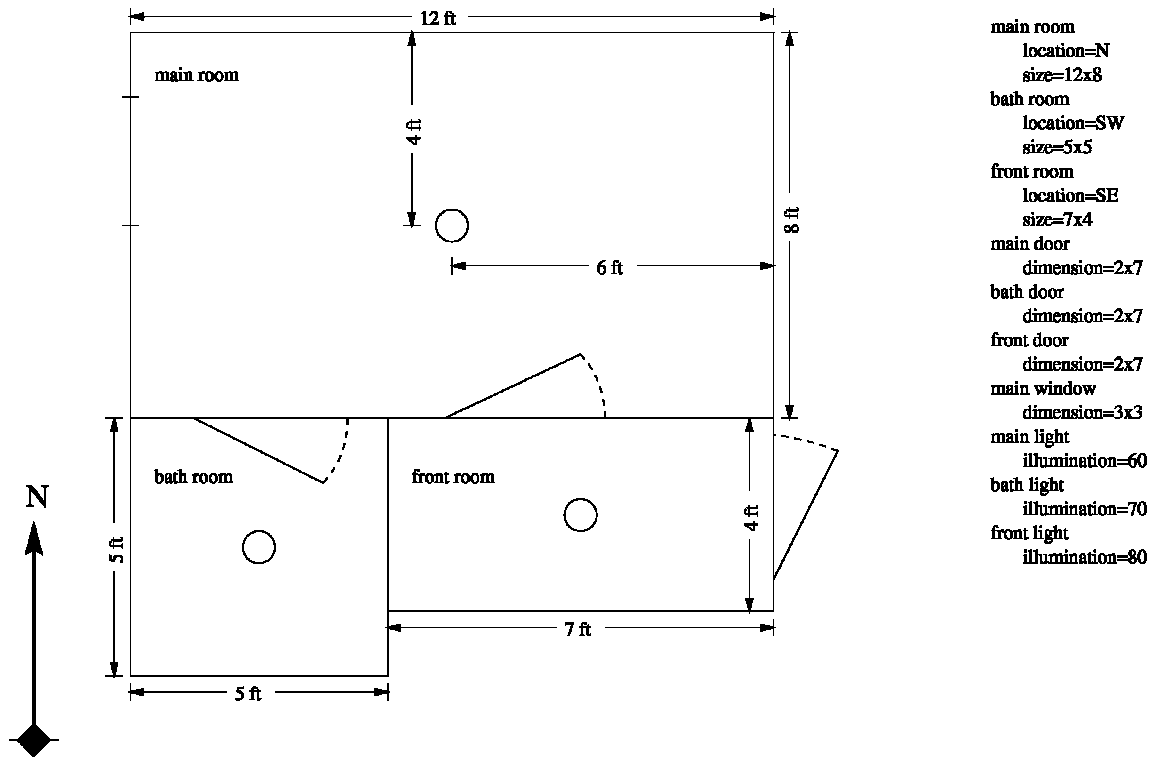

Figure 1- Floor Layout Diagram

Given a complete set of coordinates, for each part we could infer relationships between rooms, doors, windows, and lights. Additionally with some complex reasoning, we could infer some roles, for example, whether a door leads to some interior room or to the exterior of the building.

Floor Layout Object Model

Instead, let's propose a relatively simple model that includes not only the characteristics but some relationships with logical roles as well. This model diagram illustrates some common symbols defined in graphical methodologies used to convey ideas posed by ontological models.

Floor Layout Object Model

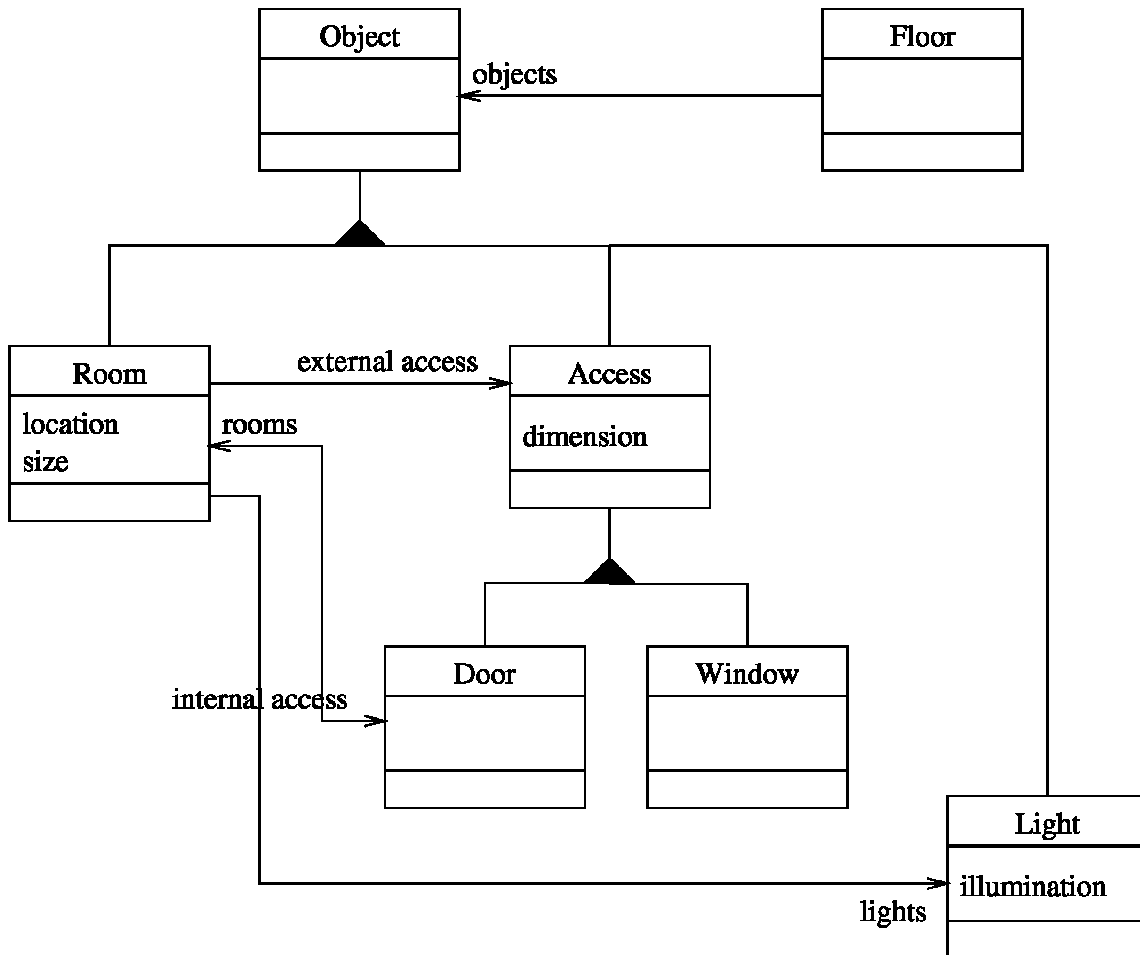

Figure 2 - Floor Layout Object Model

Recognize that we are defining kinds of things and their characteristics and relationships with other kinds of things. Take for example, a Door is shown as a kind of Access, which in turn is a kind of Object. A Door can play the role either of an external access (inherited from Access) or as an internal access with respect to a Room. Notice also that a Window may also play the role of an external access but not as an internal access (logically it does not make sense to have a Window between rooms in our simple knowledge domain). In addition, a Door can reference rooms and a Room can reference lights.

Applying this model to our actual floor layout results in this instance model representation.

Floor Layout Instance Model

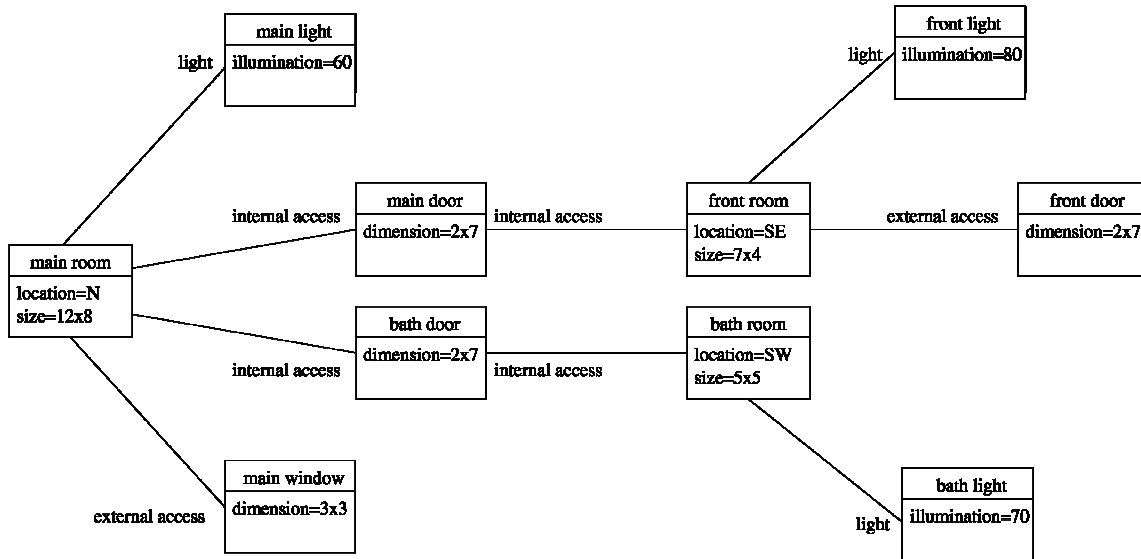

Figure 3 - Floor Layout Instance Model

Without requiring any external inference, it is easy to identify the logical relationships between the floor layout objects. For example, it is very easy to identify accesses for any room. Additionally, we can readily see which accesses are internal versus external. With some further simple deduction it is simple to determine which rooms are connected to another room through their relationships to a door (an internal access). Taking it even further it is easy to identify routes from any room to the nearest external access.

How Is an Ontological Model Developed?

The first decision is to select a language for describing the model. Good choices for a language depend highly on the intended audience, but selection of a standard methodology (such as the Unified Modeling Language) is generally good practice.

Identification of existing models and common patterns always aid the modeling process through reuse (in other words do not reinvent the wheel unless your notion of a wheel deviates significantly from everybody else's).

Creating the initial model is similar to the process for starting any creative effort (writing for example). It usually requires high level abstract, conceptual thinking. It is important to not get wrapped up into any low level details and instead focus on developing a basis from which questions may be formulated whose answers will begin to help fill in the details. An excellent starting point for most projects are the high level project requirements.

Once an initial model is developed, a knowledge acquisition process can be used to refine the model (which in turn is used to capture knowledge acquired).

Knowledge Acquisition Process

Starting with the initial model, we identify essential concepts and relationships. For example, in the floor layout example we can identify logical groupings, characteristics, and relationships from the spatial representation.

Next, we may formulate questions based on these concepts and relationships. For example, a requirement for the system may include the ability to perform lighting analyses for rooms. This may suggest a question such as "What characteristics describe a light with respect to a room?" Additionally, "What are possible external sources of light and their characteristics?" and "Are there any factors that affect these sources of light?"

Answers to these questions are best obtained from people who are experts in the domain. In many cases we are ourselves somewhat knowledgeable in the area and are certainly able to answer the questions to some degree. However, it is still useful to record the questions as part of the process.

Given the answers the model may in turn be refined to support representation of this new found knowledge and then the process is repeated until everyone is satisfied with the model.

Limitations Of Ontological Models

Models that are developed by individuals or groups tend to reflect the perspective of those individuals or groups. In and of itself this is not a problem as long as the captured knowledge includes the perspective of the audience for which the developed system is intended. In other words, any model intended to be used for information representation should be developed by a group that includes the people who will use the system dependant on the information representation.

Models that lack depth tend to be fairly static because of the dependence imposed on external systems. While not necessarily a limitation in the concept of an ontological model, most existing models lack completeness, which limits their specific application.

Extending An Ontological Model

Extension of an existing ontological model may be as simple as adding to the model itself. However, changes in the information representation may require significant changes to the system utilizing the representation. Depending on the completeness of the representation (in other words, the degree of the definition of characteristics, relationships and behavior) adding to or modifying the representation may require adding or modifying the system functionality.

If distinctly separate ontologies exist that have been implemented as services, it may be possible for a system to make use of these separate domains by providing an inter-domain translation or if you prefer mapping.

It may even be possible to dynamically add to or modify the information representation, the degree to which is highly dependent on the completeness of the representation. In other words, if the representation is flat the using system may need to infer relationships and behavior which, in turn, implies a high degree of dependence on the representation. Any changes to this representation would most likely require changes in the using system. Conversely, if the representation is reasonably complete there will be little or possibly no dependence on the representation, which would allow dynamic modifications without a requisite system change. This is in fact the "Holy Grail" that we are seeking in the search for an information representation basis for decision support systems.

Conclusion

Currently most decision support systems rely heavily on complex software agents to reason on data based on simple information representations. Even for the more advanced systems, those based on complex representations, information interpretation or inference must be performed. Future systems will be based around very complex information models that incorporate not only characteristics and relationships, but behavior as well. Ultimately, even the reasoning agents themselves will be objects, or perhaps objects will have complex behavior enabling self-contained reasoning, or more likely some combination of both will be present. Throw in the possibility of ubiquitous distributed inter-operable systems and we have the basis for a complete object based operating environment with potential that goes even far beyond decision support.

ICDM: A Development and Execution Framework for Agent-Based, Decision-Support Systems

**Kym Jason Pohl
CAD Research Center
Cal Poly, San Luis Obispo, CA 93407**

Abstract

Decision-support systems provide human decision makers with a means of solving complex problems through collaboration with collections of both human and computer-based expert agents. The ICDM Framework provides a formalized architecture together with a set of development and execution tools which can be utilized to design, develop, and execute agent-based, decision-support applications. Core to this process is the development of an ontological system providing a relationship-rich model of the application domain. Based on a three-tier architecture, ICDM incorporates forefront technologies including distributed-object servers, inference engines, and web-based presentation to provide a framework for collaborative, agent-based decision making systems rich in developmental efficiency and architectural extendibility.

Keywords

ontology, decision-support, computer-based decision making, artificial intelligence, agent, web-based computing, distributed systems, object-oriented DBMS, distributed object server, CORBA

Object-Based Representation

In modern-day society, the need for an effective means of engaging in collaborative decision making is more prevalent than ever. With the development of newer, agent-based technologies, this need is beginning to be successfully addressed.

Throughout the past decade the Collaborative Agent Design (CAD) Research Center (CADRC) at Cal Poly, San Luis Obispo, California has been intricately involved in the design and development of agent-based, decision-support systems from a practical standpoint (Pohl et al. 1997). As a result of these efforts, the CADRC has developed a manifesto of sorts describing a collection of criteria fundamental to the development of agent-based, decision-support systems (Pohl 1997).

First and foremost on this list is the need for an object-based representation of information. Information processed within the system must be described as objects having attributes, behavior, and most importantly relationships. Collectively, these descriptions form an application's information object model or ontology (Fowler and Scott 1997). This requirement not only applies to the modeling of information but at times is even portrayed in the representation of the agents themselves. It has been the experience of the CADRC that without such an objectified representation, where critical informational relationships can be captured, determination of information meaning and implication becomes extremely difficult if not impossible.

After numerous implementations it became clear to the members of the CADRC that to take full advantage of such objectified representation, a supportive framework needed to be established. A framework that centered around objects.

The ICDM Framework

The ICDM framework exists as an architecture, together with a set of development and execution tools which can be used to design, implement, and execute agent-based, decision-support applications.

The ICDM model is based on a three-tier architecture making clear and distinct separations between information, logic, and presentation (Gray et al. 1997). These tiers are represented by the three major components comprising the ICDM model; a collection of information management servers (i.e., Information Server, Subscription Server, etc.) (information tier), the Agent Engine (logic tier), and the Client User Interface (presentation tier) (Figure 1). Each of these components functions in an integrated fashion to form a comprehensive agent-based decision-support execution framework. This framework allows multiple human decision-makers to solve complex problems in a collaborative fashion obtaining decision-support assistance from a collection of heterogeneous on-line agents.

Information Server

Core to the information tier is the Information Server (IS). Conceptually, the IS represents a library of objectified information which clients utilize to both obtain and contribute information. The only difference is that clients can obtain this information in, not only a *pull* fashion (query service), but can also have the IS *push* them information on

an interest basis (subscription service). Physically, the IS exists as a distributed object server based on the Common Object Request Broker Architecture (CORBA) (Mowbray and Zahavi 1995).

Being the basis for the IS, distributed object servers are designed to service client requests for information. The knowledge of exactly where the information resides and how it can be retrieved is completely encapsulated inside the object server. This means that clients need not be concerned with who has what information and in what form that information exists. This feature becomes instrumental in providing an environment where collaborative application components operate in a de-coupled manner via the IS.

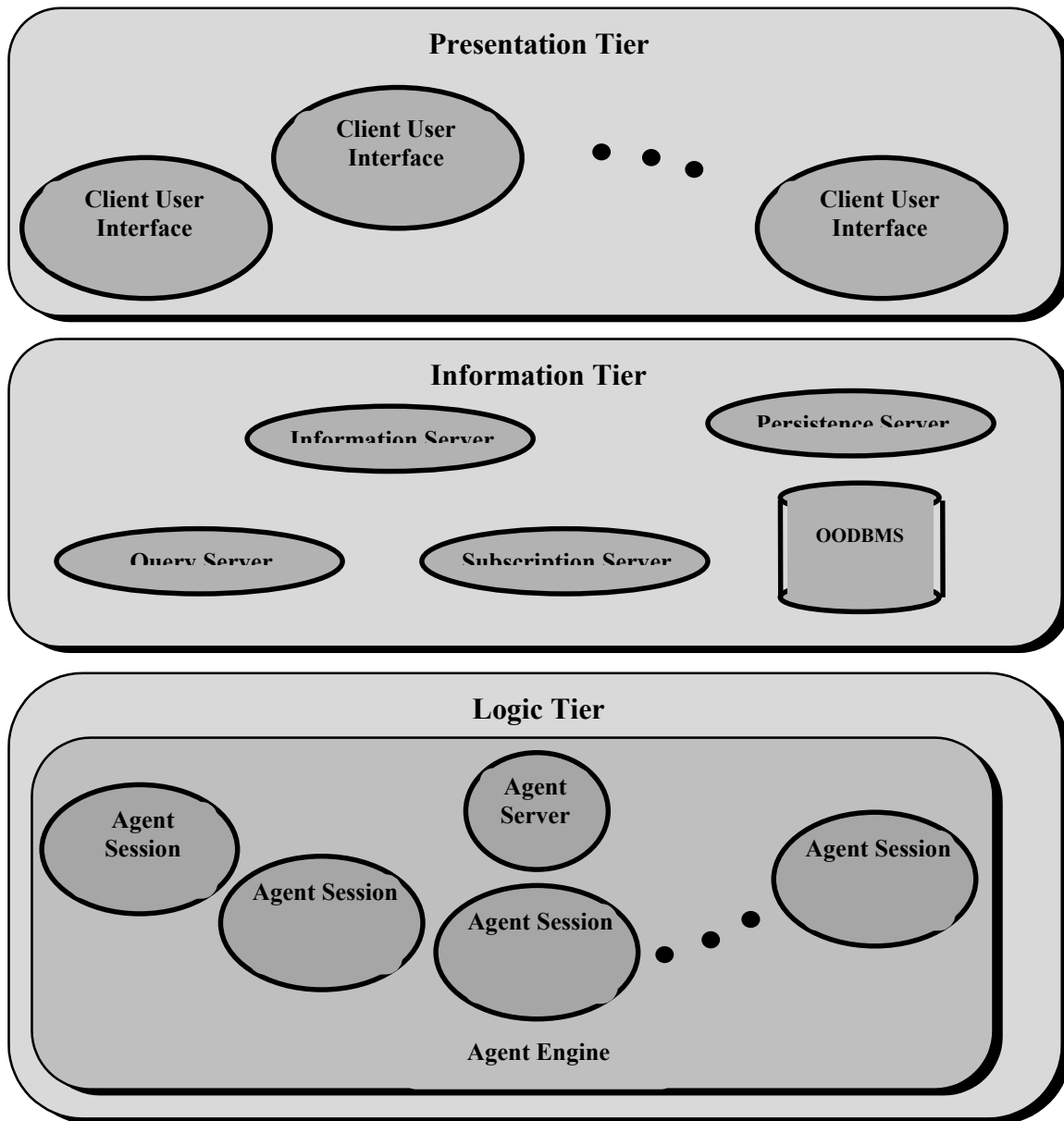

Figure 1 – 3-Tier Architecture

Regardless of the information's native representation, distributed object servers can be used to present information to clients in the form of objects. However, this does not discount the need for information to be modeled as high-level objects in its native form portraying behavior and conveying relationships. While on the surface this representational morphing capability of object servers seems promising, in practice this feature proves to be quite misleading. If the information is not represented at a high level upon its conception, such objectification amounts to little more than wrapping data in communicable object shells. These shells fail to convey any additional insight into the meaning or implication of the information than was present to begin with in its original form. Although in the future there may be potential for successful research efforts in this area, at present, unless information is originally modeled as objects, knowledge-oriented applications prove to gain little from this distributed object server feature.

However, applications that do, in fact, model information as high-level objects stand to gain considerably from employing distributed object servers. Distributed object servers preserve purely objectified representations of information as it moves throughout the system. This is due to the fact that the internal mechanisms of distributed object servers process information as objects themselves.

The ICDM model takes full advantage of these object-oriented facilities by integrating an Object-Oriented DBMS (OODBMS) (Bancilhon et al. 1992) into its information environment. The OODBMS is the facility that the IS uses to store the application's objects. Employing an OODBMS to store the information objects has two significant advantages.

First, an OODBMS retains the object-oriented representational nature of the information as it exists in its persistent form. Whenever there is representational degradation there is potential for loss of informational content and meaning. By utilizing both access and storage facilities which are capable of processing and manipulating information as objects, there is no degradation of representation as information flows throughout the application environment.

The second advantage of employing an OODBMS relates to the manner in which IS clients request information. Whether mining for information or posting a standing subscription, clients formulate their information requests in terms of objects. More specifically these requests are described in terms of object attributes and object relationships. These queries can range from simple existence criteria to the more complex incorporating both logical and relational operators.

Another method in which information can be obtained from the Information Tier deals with the notion of subscription. Clients can dynamically register standing subscriptions that are again described in terms of the application's ontological system. For example, a client may request to be notified whenever InfoTech hires a new employee. Once registered, the Subscription Server continually monitors this condition.

When satisfied, the Subscription Server essentially *pushes* the results to whomever has indicated an interest (i.e., registered an appropriate subscription). The alternative to this subscription mechanism would be to have interested clients perform the same query on an iterative basis until such a condition occurs. Each unsatisfied query may potentially decrease resources (i.e., computing cycles) available to other application components and would essentially prove to be a waste of time. If a client takes a more conservative approach where the repeated query is made on a less frequent basis, the client risks being out of date with the current state of affairs until the next iteration is performed. With this in mind, the incorporation of a *push information to interested clients* mechanism becomes essential in providing decision-support applications with an efficient, up-to-date operating environment.

Agent Engine

The Agent Engine represents the logic-tier of ICDM's underlying three-tier architecture. Existing as a client to the Information Tier services (i.e., access, query, subscription, and persistence) the Agent Engine is capable of both obtaining and injecting information. Architecturally, the Agent Engine consists of an agent server capable of serving collections of agents (Figure 1). These collections, or Agent Sessions, exist as self-contained, self-managing agent communities capable of interacting with the Information Tier to both acquire and inject information. For the most part, the exact nature of agents and collaborative model employed is left to the application specification. However, regardless of the types of agents contained in an Agent Session, agent activity is triggered by changes in application information. This information may take the form of global objects managed by the Information Tier or local objects utilized in agent collaboration which are managed by the Agent Session itself. Regardless of whether agents are interacting with the Information Tier or each other, interaction takes place in terms of objects. This again illustrates the degree to which an object representation is preserved as information is processed throughout the application environment.

Agent Session Configuration

Breaking agent analysis into heterogeneous collections of agents allows for a number of interesting configurations. These configurations determine the size, number, and individual scope of the agent sessions. While a wide variety of Agent Session configurations exist, the CADRC has found considerable success in formulating this configuration based on two primary criteria.

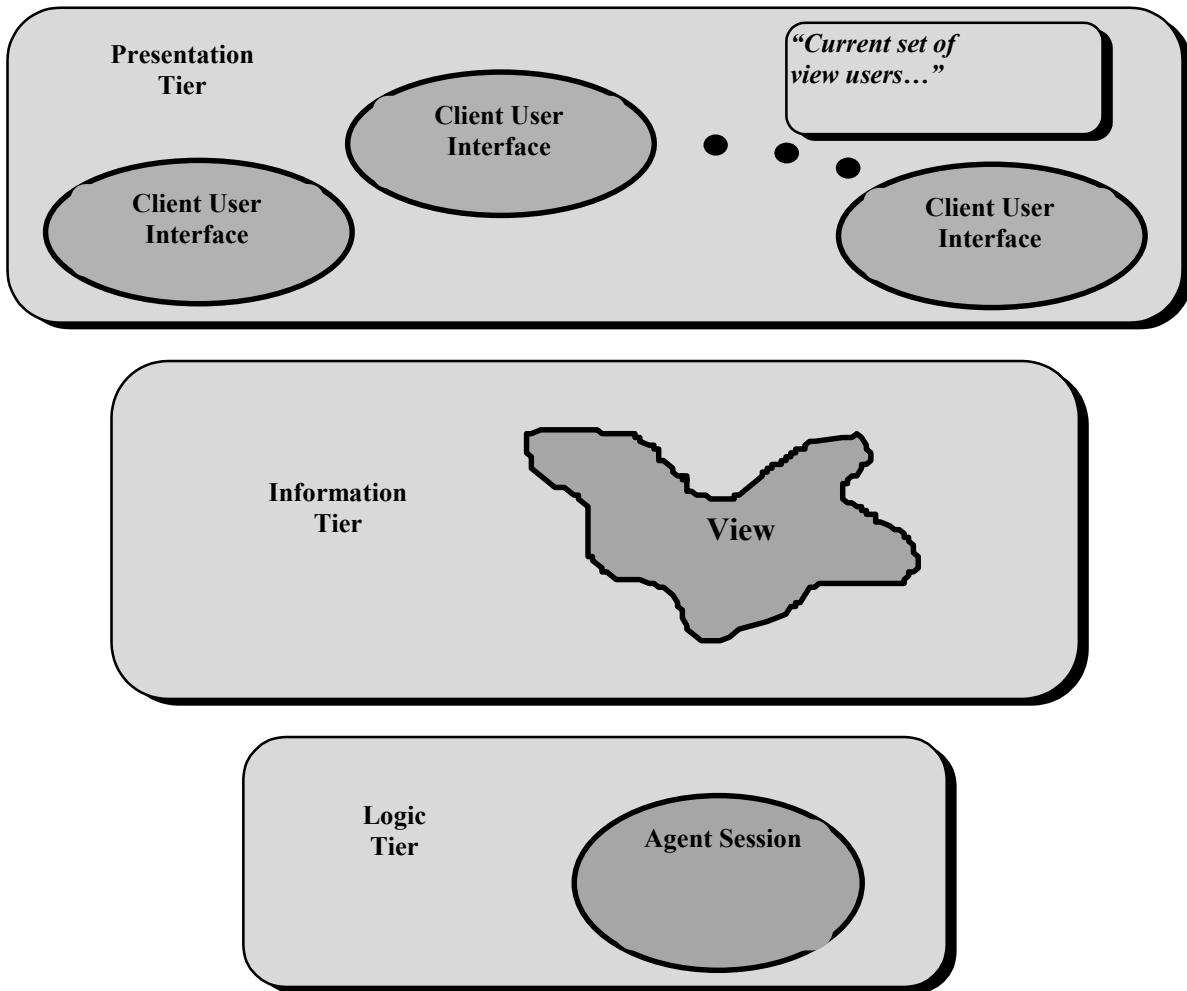

Figure 2 - Multiple users can interact with a view which in turn is analyzed by a single Agent Session

The first criterion introduces the notion of a *view*. A view is a conceptual perspective of reality. In other words, a view can be thought of as a single investigation into solving a problem whether it is based on fact or speculation. For example, a view may describe events and information relating to what is actually occurring in reality. Yet, another view may describe an alternative or desired reality. An illustration of this approach can be observed in the Integrated Marine Multi-Agent Command and Control System (IMMACCS) developed by the CADRC for the Marine Corps. IMMACCS uses a single view to represent the information and events occurring in the battlespace. In a similar manner, IMMACCS employs any number of additional views to represent hypothetical investigations to determine suitable strategies for dealing with potential events or circumstances. Regardless of use, however, there is a one-to-one correspondence between a conceptual view and an Agent Session (Figure 2). This means that independent of exactly which version of reality a view represents, there exists dedicated Agent Session providing users of that view with agent-based analysis and

decision-support. Each agent of a particular Agent Session deals only with the view associated with its Agent Session. Organizing information analysis in this manner allows for an efficient and effective means of distinguishing information and activities relating to one view from those pertaining to another. Unless prompted by user intervention (i.e., user-directed movement of information between views), each set of information is completely disjoint from the other.

The second configuration criterion employed by the CADRC determines the quantity and nature of agents contained in an Agent Session at any point in time. As mentioned above, the decision-support applications developed by the CADRC utilize a variety of agent types. Three of these agent types include Domain Agents, Object Agents, and Mediator Agents (Pohl 1995). Recall that service-oriented Domain Agents embody expertise in various application-relevant domains (i.e., structural systems and thermal dynamics for architectural design, tidal dynamics and trim and stability for ship stow planning, etc.). The collection of Domain Agents populating an Agent Session at any point in time determines the variety of domain specific perspectives and analytical depth available during analysis of the associated view. Under the configuration scheme utilized by the CADRC, users can add or remove these domain perspectives in a dynamic fashion over time.

Object Agents, on-the-other-hand extend the notion of high-level informational representation by essentially *agentifying* information through empowering information objects with the ability to act on their own behalf. Both human users and other agents as needed can initiate this agentification of information into Object Agents.

In an attempt to resolve conflicts arising between collaborating agents, Mediation Agents may be employed as third party mediators. It is the goal of these mediators to bring about consensus among agents that may have reached an impasse.

Under the ICDM model each of these agent contingents is dynamically configurable by both the user(s) in addition to the system itself. This approach to Agent Session configuration promotes the notion of offering assistance in the form of dynamically configurable tools rather than predefined solutions (Pohl 1997).

Agent Session Architecture

Architecturally, an Agent Session consists of several components including the Semantic Network and Semantic Network Manager, Session Manager, Inference Engine, and Agent Manager (Figure 3). These components operate in an integrated fashion to maintain a current information connection between the agents residing in the Agent Session and the associated view described in the Information Tier.

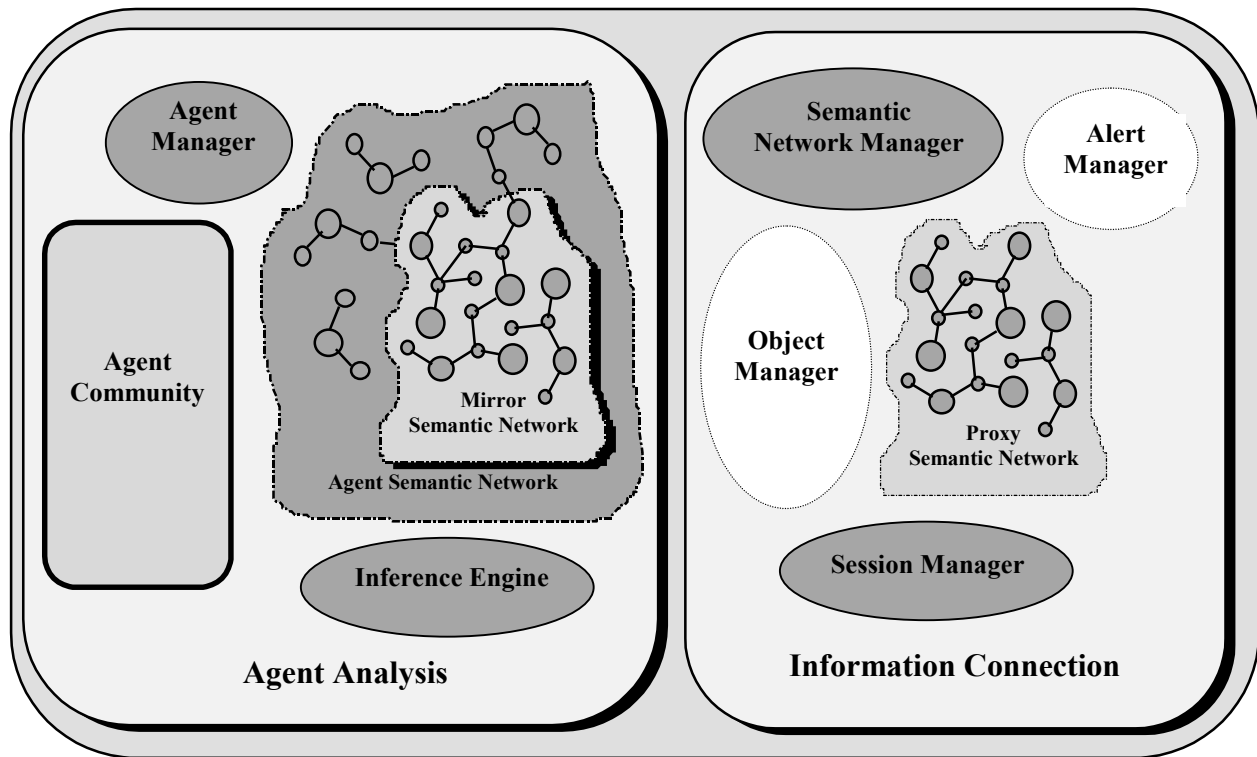

Figure 3 - Agent Session Architecture

Semantic Network

The Semantic Network consists of a collection of two sets of application specific information objects. The first set is used for local collaboration among agents. Depending on the specific collaborative model employed, agents may use this local Semantic Network to propose recommendations to each other or request various services. This information is produced and modified by the agents and remains local to the Agent Session. The second set of information is a sort of duplicate, mirror image of the view information stored in the Information Tier. In actuality, this information exists as a collection of object-based interfaces allowing access to view information stored in the Information Server. Such interfaces are directly related to the application's ontological system. In other words, these interfaces, or proxies (Mowbray and Zahavi 1995), are represented in terms of the objects described in the information object model. Through these interfaces, Information Server clients have the ability to access and modify objects contained in the Information Tier as though they are local to the client's environment. All communication between the object interfaces and their remote object counterparts is encapsulated and managed by the Information Server and completely transparent to the clients. This is a fundamental feature of distributed object servers on which the Information Server is based (Orfali et al. 1996).

Semantic Network Manager

As the primary manager of the two sets of information described above, the Semantic Network (SN) Manager focuses the majority of its efforts on the management of the bi-directional propagation of information between Information Server proxies and an equivalent representation understandable by the Inference Engine. Such propagation is accomplished through employing an Object Manager. The purpose of this manager is to essentially maintain mappings between the object proxies and their corresponding Inference Engine counterparts. The necessity of this mapping reveals a limitation inherent in most distributed object server and inference engine facilities. Most facilities supporting one of these two services require control over either the way client information is represented or the manner in which it is generated. This is due to the fact that both facilities require specific behavior to be present in each object they process. Examples of such facilities include IONA's ORBIX distributed object server (IONA 1996) and NASA's CLIPS inference engine (NASA 1992). Both of these facilities suffer from this limitation. Nonetheless, this dilemma can be solved through the use of an intermediate object manager which maintains mappings between the two sets of objects.

An additional responsibility of the SN Manager deals with the subscriptions, or interests held on behalf of the agent community. That is, the SN Manager is responsible for maintaining the registration of a dynamically changing set of information interests held on behalf of the Agent Session agents. In addition, the SN Manager is responsible for processing notification(s) when these interests are subsequently satisfied. Such processing includes the propagation of information changes to the agent community that may in turn trigger agent activity. To perform these two interest-related tasks the SN Manager employs the services of the Alert Manager. The Alert Manager provides an interface to the Subscription Server facility and is available to any Information Tier client wishing to maintain a set of information interests. Employment of the Alert Manager by subscribers has two distinct advantages. First, clients are effectively de-coupled from the specifics of the subscription interface. This allows the same application client to be compatible with a variety of object server implementations. Second, the Alert Manager interface allows subscribers to effectively decompose themselves into a dynamic collection of thread-based interest clients (Lewis and Berg 1996). That is, the Alert Manager extends the monolithic one-to-one relationship between the Subscription Server and its clients into one that supports a one-to-many relationship. Such decomposition of functionally related behavior into lightweight processes promotes the concepts of multi-processing in conjunction with resource conservation.

Inference Engine

The Inference Engine provides the link between changes occurring in the Semantic Network and agent activation. Recall that agent activation can occur when a change in the Semantic Network is of interest to a particular agent. In such a case, the

Inference Engine, having knowledge of specific agent interests in addition to changes occurring in the Semantic Network is responsible for activating, or scheduling the action(s) the agent wishes to execute. This activation list forms the basis for the Agent Manager to determine which agent actions to execute on behalf of the currently scheduled agent.

Agent Manager

The Agent Manager is responsible for the management of the agent community housed in an Agent Session. This management includes the instantiation and destruction of agents as they are dynamically allocated and deallocated to and from the agent community. In addition, the Agent Manager is responsible for managing the distribution of execution cycles allowing each agent to perform operations. Disbursement of execution cycles occurs in a round-robin fashion allowing agent analysis to be evenly distributed among relevant agents. Whether or not an agent utilizes its allotted cycles depends on whether it has any tasks or actions to perform.

Session Manager

As the overall manager of the Agent Session environment the Session Manager has two main responsibilities. The first of these responsibilities focuses on the initialization of each of the other Agent Session components upon creation. When an Agent Session is created as a response to the creation of a view, the Session Manager is the first component to be activated. Once initialized, the Session Manager activates the SN Manager and Inference Engine. Continuing its efforts, the Session Manager then activates the Agent Manager. Upon startup, the Agent Manager initializes itself by allocating an appropriate initial set of agents. Depending on the application specifics, these agents may in turn perform a series of initial queries and subscriptions which will eventually propagate to the Information Tier via the SN Manager.

Client User Interface

Representing the third and final tier of the three-tier architecture employed by ICDM the Client User Interface (CUI) exists as a web-based application which can operate in a light-weight computing environment. The CUI essentially provides human users with a means of viewing and manipulating the information and analysis provided by the other two tiers of the agent-based, decision-support application. Understanding the importance of data presentation, the CUI presents the user with this information and analysis in a robust and graphical manner.

As clients of the IS, CUI users have the ability to interact with each other in a collaborative fashion. That is, by virtue of either injecting or obtaining information from the IS, CUI users working on the same view have the potential of exchanging relevant information in a collaborative manner. This type of information exchange occurs regardless of whether the view represents the main design effort or exists as a localized solution attempt explored by a subset of users. All information and analysis remains localized within its particular view unless explicitly copied into another view as a user

initiated action. In this manner, no informational or analytical collisions occur between conceptual views without the potential for user-based supervision and subsequent reconciliation.

Development Toolkit

As a further formalization of the ICDM approach to agent-based, decision-support applications, the CADRC is continuing their development of a collection of design and development tools to accompany the execution framework discussed above. These tools essentially combine the roles of application designer and application developer into a single effort. Decision-support applications can be designed and developed through a series of high-level models describing information structure and analytical logic. High-level classes can be identified through a series of Unified Modeling Language (UML) (Fowler and Scott 1997) class diagrams forming a comprehensive information object model. This model essentially describes the application specific design and problem space as a collection of high-level objects complete with attributes and relationships. This is the same high-level description of application information identified earlier as being crucial to agent-based, decision-support applications.

By the same token, it is the belief of the CADRC that much of the analytical reasoning applied to this information can be described in terms of a methodology suitable for representing object-based logic. Though currently at the theoretical stage, the methodology intended to be employed to serve this purpose attempts to represent logic as a series of rules (Hayes-Roth et al. 1983). Each of these rules identifies both a condition and a corresponding action to take upon the satisfaction of that condition. This is where the advantages of using a high-level, object-based representation again become apparent. It is the belief of the CADRC that both the condition and action components of these rules can be described in terms of the application's information object model. That is, conditions can be represented as a series of constrained references to object attributes strung together with logical and relational operators. The corresponding rule action is itself described in terms of a series of basic manipulation functions (i.e., create, modify, delete) executed against the information object model. When the informational state described in the condition section of the rule occurs, the corresponding action component will modify or produce information thus creating an entirely new informational state. This new state may in turn trigger other rules to execute in a similar fashion. Although not all logic can be represented in this manner, it is the expectation of the CADRC that this approach can be applied to a significant portion of analytical reasoning found in decision-support applications.

Using high-level design models that describe both domain information and domain logic as input, the ICDM Toolkit allows for the automatic generation of a significant portion of the supporting decision-support system. In other words, using the ICDM Toolkit the information object model can be used as a basis for automatically generating basic (i.e., construction, attribute-level modification, and destruction) object-specific behavior. In a similar manner, the logic model can be used to automatically generate the condition and action components of the agent rules representing the logic-tier of a decision-support application.

By elevating the vast majority of agent-based, decision-support application development to the level of conceptual design, such applications can be developed, maintained, and modified in a considerably more efficient and proficient manner as compared to a more manual, implementation-specific approach. Further, this approach essentially eliminates the loss of intent that often occurs as application development moves from the designers to the program developers. Utilizing the ICDM model together with its design and development tools these roles essentially become synonymous.

References

Bancilhon F, C Delobel and P Kanellakis (eds.); "*Building an Object-Oriented Database Systems*"; Morgan Kaufman, San Mateo, CA, 1992.

Fowler M and K Scott; "*UML Distilled: Applying the Standard Object Modeling Language*"; Addison-Wesley, Reading, Massachusetts, 1997.

Gray S and R Lievano; "*Microsoft Transaction Server 2.0*"; SAMS Publishing, Indianapolis, Indiana, 1997.

Hayes-Roth F, D Waterman and D Lenat (eds.); "*Building Expert Systems*"; Addison-Wesley, Reading, Massachusetts, 1983.

IONA; "*Orbix Web: Programming Guide*"; IONA Technologies Ltd., Dublin, Ireland, 1996.

Lewis B and D J Berg; "*Threads Primer: A Guide to Multithreaded Programming*"; SunSoft Press; Mountain View, CA, 1996.

Mowbray T and R Zahavi; "*The Essential CORBA: Systems Integration Using Distributed Objects*"; John Wiley and Sons, Inc., New York, New York, CA, 1995.

NASA; "*CLIPS 6.0 Reference Manual*"; Software Technologies Branch, Lyndon B Space Center, Houston, Texas, 1992.

Orfali R, D Harkey and J Edwards; "*The Essential Distributed Objects Survival Guide*"; John Wiley and Sons, Inc., New York, New York, CA, 1996.

Penmetcha K, A Chapman and A Antelman; "*CIAT: Collaborative Infrastructure Assessment Tool*"; in Pohl J (ed.) *Advances in Collaborative Design and Decision-Support Systems*, focus symposium: International Conference on Systems Research, Informatics and Cybernetics, Baden-Baden, Germany, August 18-22, 1997 (pp. 83-90).

Pohl J, A Chapman, K Pohl, J Primrose and A Wozniak; "*Decision-Support Systems: Notions, Prototypes, and In-Use Applications*"; Technical Report, CADRU-11-97, CAD Research Center, Design Institute, College of Architecture and Environmental Design, Cal Poly, San Luis Obispo, CA, January, 1997.

Pohl J; "*Human-Computer Partnership in Decision-Support Systems: Some Design Guidelines*"; in Pohl J (ed.) *Advances in Collaborative Design and Decision-Support Systems*, focus symposium: International Conference on Systems Research, Informatics and Cybernetics, Baden-Baden, Germany, August 18-22, 1997 (pp. 71-82).

Pohl K; "*KOALA: An Object-Agent Design System*"; in Pohl J (ed.) *Advances in Cooperative Environmental Decision Systems*, focus symposium: International Conference on Systems Research, Informatics and Cybernetics, Baden-Baden, Germany, August 14-18, 1995 (pp. 81-92).

Object Based Communications for Distributed Collaborative Decision Support Systems

Thomas McVittie, Ph.D.

Jet Propulsion Laboratory

California Institute of Technology



Object Based Communications for Distributed Collaborative Decision Support Systems

Dr. Thomas McVittie
Thomas.i.McVittie@jpl.nasa.gov
(818)393-5052

Reliable Distributed Systems Group (369)
Jet Propulsion Laboratory
California Institute of Technology



Decisions



- Decision are made at **ALL** levels throughout an organization.
- **TYPE** and **SCOPE** of decisions vary greatly
- Type and amount of information/data needed to make a decision varies:
 - type of decision being made
 - wants/needs of decision maker
 - information availability



Data/Information



- We have ever increasing potential to access a rich data environment
 - sensors, national feeds, reports
- Need to support the ability to maintain
 - Low level data
 - Higher level information/knowledge
 - Linkages between the two.
- To avoid data/information overload, we must provide the ability to dynamically filter, query and subscribe to information sources.



Goal



- Build a family of systems which can be used to support the information needs of a variety of decision support systems.
- Characteristics:
 - Dynamically **tailored information feeds**.
 - **Scalable architecture** supporting stand-alone & distributed systems
 - **Adaptable** - able to adapt to changes in the environment
 - **Timely** - information/data must be current *enough* to meet mission needs.
 - **Available** - system must be able to provide service when requested.
 - Data **Integrity** - consistent, correct, & guarded from unauthorized modification
 - Data **Privacy** - information/data available only to authorized users.
 - **Testable** - system should be designed to support testing.



The Problem



- Building Decision Support Systems (DSS) is **hard**.
 - Subject expertise, knowledge representation, & decision algs
- Building Collaborative DSS is **harder**.
 - Synchronization, common knowledge representations & communications models, timing, & progress.
- Building Distributed Collaborative DSS is even **harder**.
 - Server/communications failures, information replication and consistency, security, global timing
- Building Real-World Distributed Collaborative DSS is **harder still**.
 - Unexpected interactions, external events, extended time delays

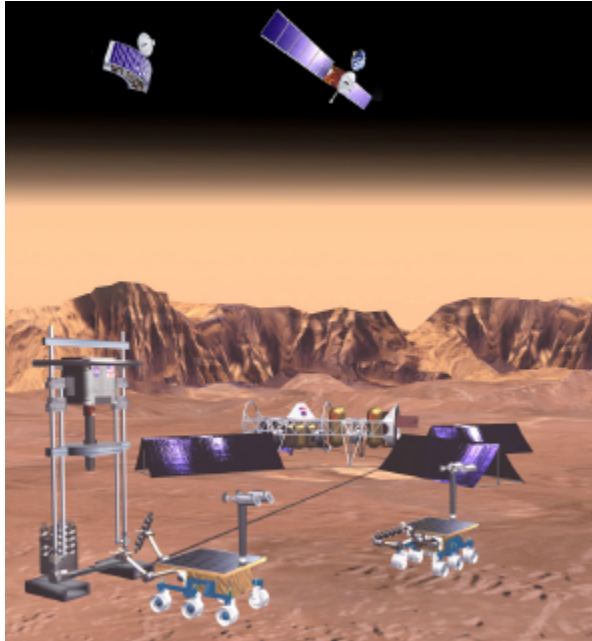

Mars-Net

Collaborating:

- Rovers,
 - Probes,
 - Orbiters,
 - Micro & Long Haul Relays
 - Earth-based Scientists & mission controllers
- Earth-based big decisions & goals.
 - Semi-autonomous local decisions
 - Multiple countries
 - Fielding 2006-2012



JMADSS/Shared Net

Mars-Net Architecture

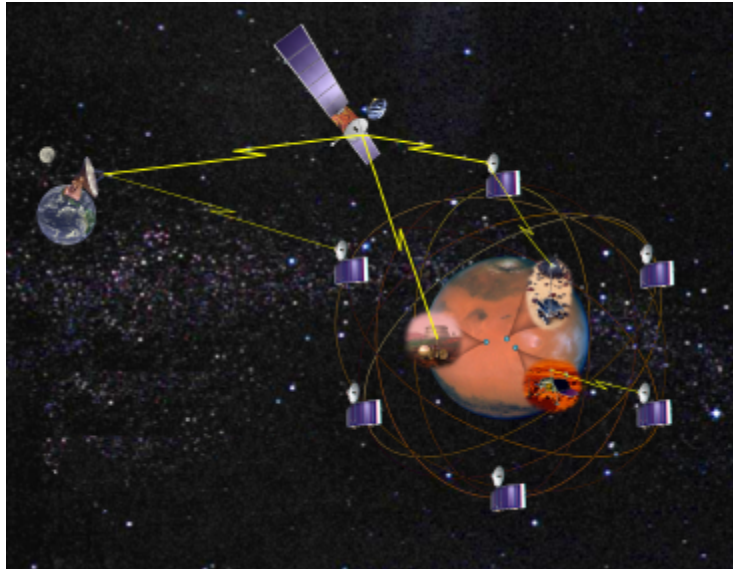



Implementation Goals



- Support the secure **storage/retrieval/distribution** of both low level data and higher level information/knowledge.
- Provide a **framework** which **isolates** Decision Support systems from knowledge of where information is located and how it is distributed & maintained.
- Adopt an open approach which supports **expandability** and **adaptability**.
 - Abstract away from things that can change in the environment
 - Allow open component development.
- Use **COTS** components if possible.
 - Assumes it was developed for a similar target use or is adaptable.



Approach



- Use an iterative rapid development methodology.
- Phased Development approach
 - Provide support for Decision Support Systems
 - Adapt system to support distributed systems
 - Adapt system to support particular real-world use scenarios.
- Use Periodic fielding to identify and isolate problems.



Storage/Retrieval/Distribution



- Goal: Support the secure **storage/retrieval/distribution** of both low level data and higher level information/knowledge
- **Use Objects & Relations** as the High Level representation of information.
 - Objects mimic real-world objects
 - Relationships between objects which represent real-world relationships.
- Provide tools allowing clients to
 - **Pull** objects and relationships from the common repository (*Query*)
 - **Subscribe** to have objects/relationships **Pushed** to them when they change.



A Simple Collaborative Example

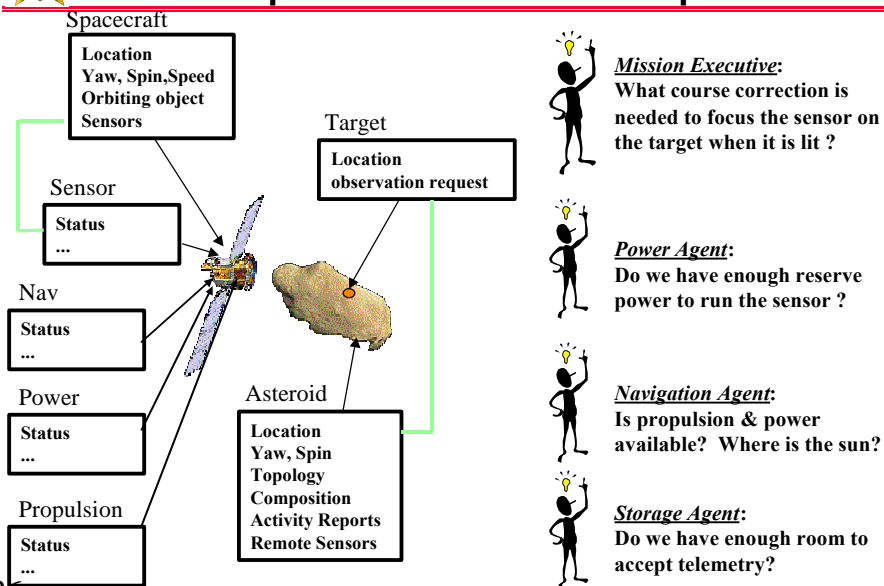



Framework



- Goal: **Isolate** components from knowledge of where objects are stored, and how they are distributed.
- Use CORBA as basis of framework
 - Native support for objects
 - Support for multiple languages and platforms
 - Rich set of COTS tools

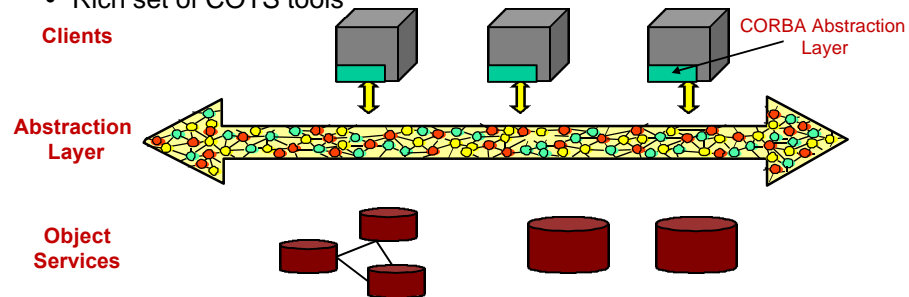

Initial Implementation



- You don't fully understand (or have the ability to accurately predict) the behavior of a real-world system until you actually build and field it.
 - In building real world systems of any complexity, there can be any number of unexpected interaction faults.
 - Reused components, while of high quality, may not behave as we expect.
- Mars is very harsh and time delays make it very difficult to use as a test bed.



Phase 1 Collaboration



- USMC has very similar interests & needs
 - Desire for Decision Support for simultaneous events
 - Interest in objectification of the environment (battlespace)
 - Need to work under hostile conditions
 - Small level of funding.

- ELB's Communication Topology is similar to Mars-Net
 - Although technologies and timing characteristics are very different.



USMC IMMACCS/ELB



Very similar architecture

Very similar needs

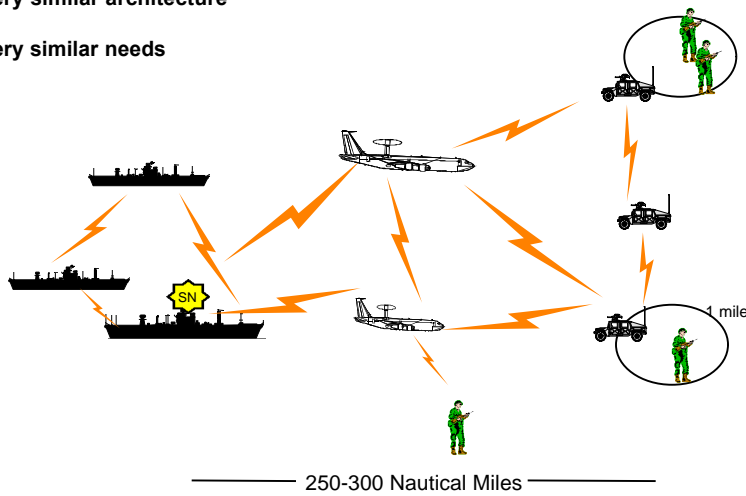

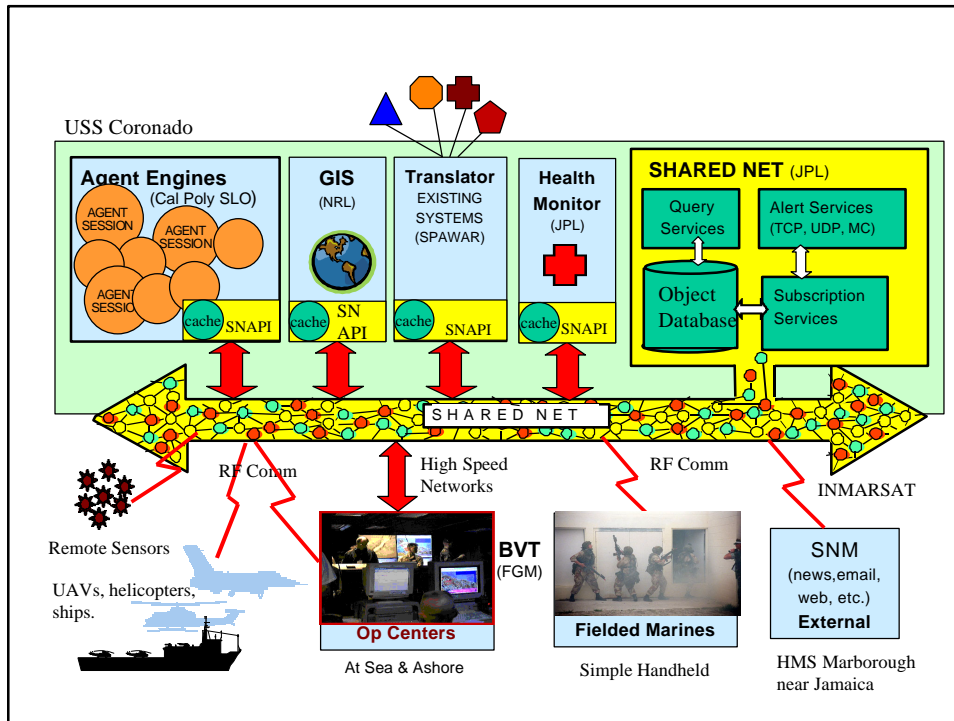

JMADSS/Shared Net



Phase 1 - Observations



- Building Collaborative Decision Support systems is hard.
- Ability to abstract away from both the object servers and CORBA proved invaluable.
- Architecture proved to be very extensible
 - changes in the object model & new types of clients
- Current client-server architecture will not scale efficiently.
 - Single point of failures
 - inefficient use of communications systems
- Adaptability of COTS products can be severely limiting.
 - Internal protocols may not adapt to new networks/protocols.
 - Time interval between bug isolation and repair can be very long.

129



Phase 1.1 - Adaptation



- Based on Observations, adapt phase 1 components
- Increase scalability and use network more efficiently by broadcasting subscriptions.
- Patch COTS software to include fixes for our more common problems.
- Scheduled to begin testing this week.



Architectural Options



- Single central machine architecture is likely not enough
 - Too much information to process efficiently (time delays)
 - Processing load is too large - particularly if a lot of clients.
 - Single point of failure.
- Decentralized independent data stores
 - Some decisions require a broad scope of data which may need to be pulled from a wide variety of hosts
- Hybrid Approach
 - Collection of distributed processing nodes able to share information in a variety of other nodes.
 - Peer-peer, reporting, independent, superior
 - Nodes are likely to be distributed with intermittent connections.
 - Must be able to prioritize events which have strong impact on decisions.



USMC IMMACCS/ELB



Collection of Object Serving Nodes

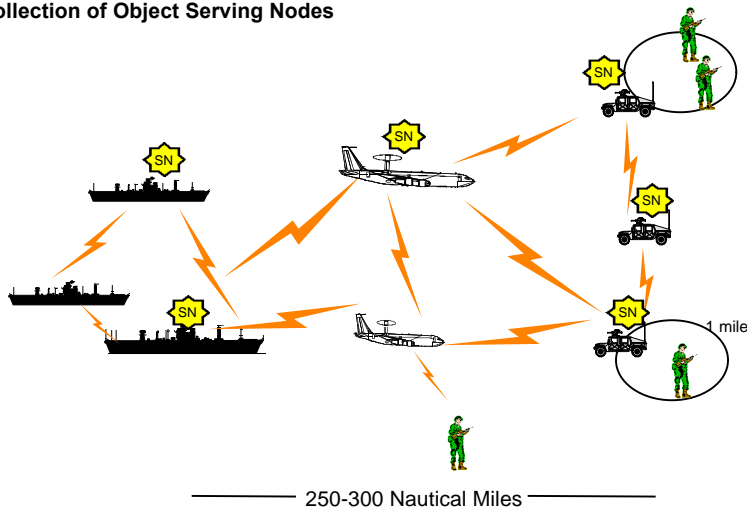

Architecture must take into account:

- Information Sharing Density -
 - How many systems are sharing the same objects?
 - How many systems are updating vs reading the objects?
 - Probability that a change to an object made by one component will impact the decision(s) made by another component.
- Locality of Information -
 - Are the systems accessing this object nearby, remote, or a combination?
 - How connected are the machines?
- Timeliness of Information
 - What is the maximum latency we can tolerate?
 - Does a system always need the latest data, or can they use older data?



Focuses of Phase 2 Research



- Transparent Fault Tolerance
- Information Consistency in distributed databases connected via unreliable networks.
- Efficient distributed authentication and authorization
- Migration to real-time operating systems and real-time CORBA.



Further Information

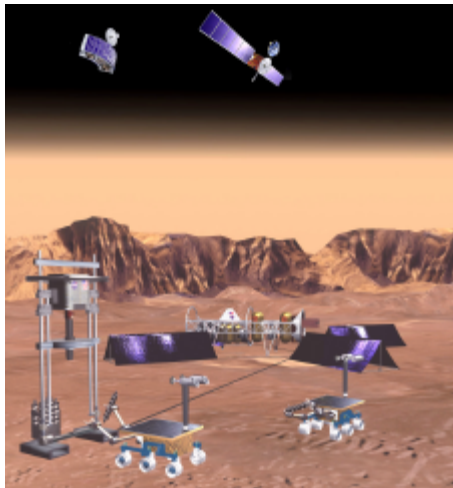

- Mars-Net:
<http://marsnet.jpl.nasa.gov>
- Shared Net
<http://snserv.jpl.nasa.gov>

Some Risks of Misusing Information Technology

Gary Klein, Ph.D.

Chief Scientist

Klein Associates



Some Risks of Misusing Information Technology

Gary Klein, Ph.D.

Klein Associates Inc.

Fairborn, OH 45324

937-873-8166

gary@klein-inc.com

www.decisionmaking.com

Presented to:

Second Annual ONR/CADRC

Decision Support Workshop

San Luis Obispo, CA

4 May 2000

KLEIN

ASSOCIATES INC.

Air Weather Service Technologies Introduced in Last 20 Years

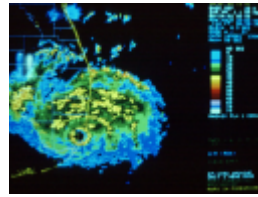

- Satellite downlink of meteorological data
- Doppler radar (NEXRAD)
- Automated Weather Distribution Systems (AWDS)
- 3-D and 4-D visualization products
- Automated Surface Observing Systems (ASOS)

KLEIN

ASSOCIATES INC.

Historical Forecasting Skill



134 KLEIN

ASSOCIATES INC.

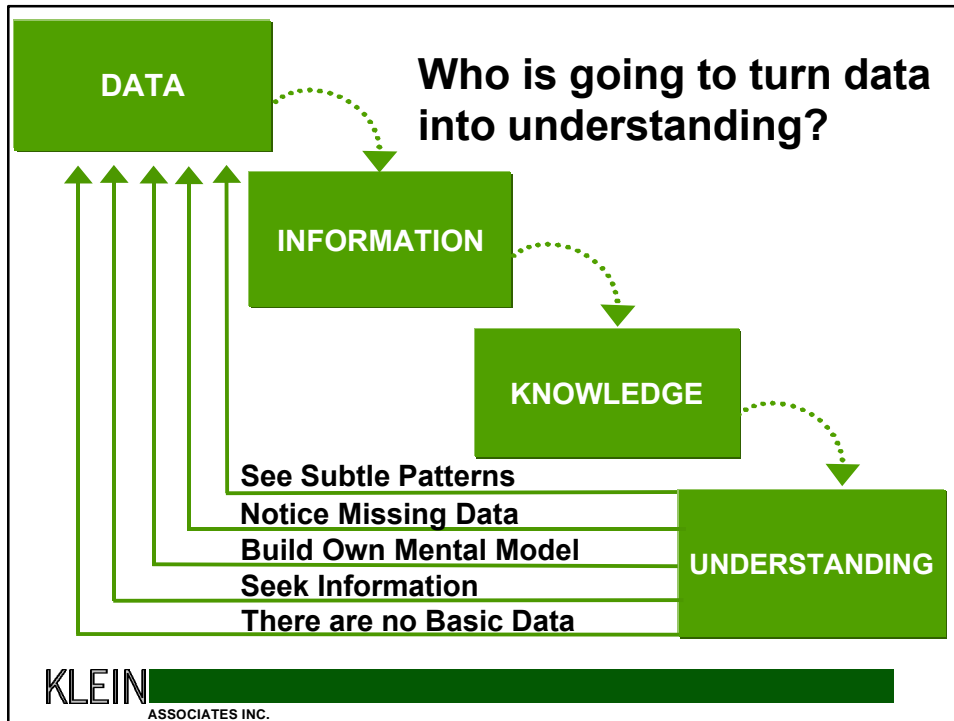

Can We Make People Stupid?



- **Excessive data**
 - Passive attitude
 - Limited information seeking
- **Reduce confidence**
- **Pre-processed data**
- **Procedural mentality**
 - Freeze the database categories
- **Low-cost, rapid advice and feedback**
- **Formal analyses and task decomposition**
- **Use simplistic metrics**
- **Attention management**

Observations

Regiments: Camp Pendleton, Camp Lejeune, 29 Palms,
7/12 regiments

MEF: Three years of observations at Phase III exercises,
one Phase II exercise

Battalion exercise at 29 Palms

Hunter Warrior

KLEIN

ASSOCIATES INC.

MEF Planning Flow

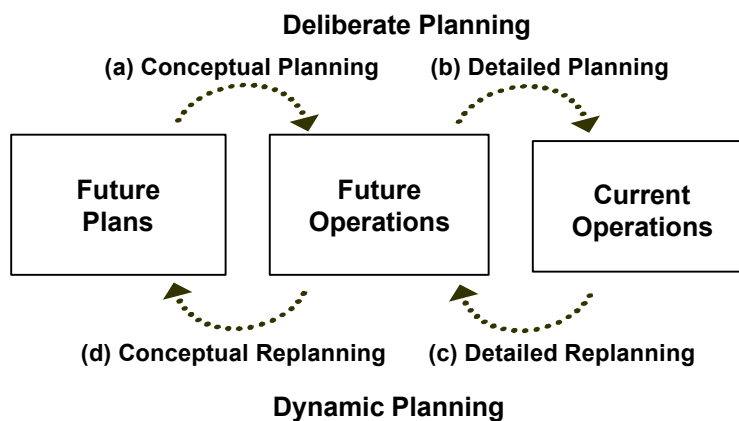

136 KLEIN

ASSOCIATES INC.

Decision-Centered Design

- Contrast to technology-driven design
- Focus on key decisions
 - What they are?
 - Why they are difficult?
 - How they are made?
- Review critical incidents to identify decision requirements
- Use IT to support decision requirements

KLEIN

ASSOCIATES INC.

Definition of Cognitive Task Analysis

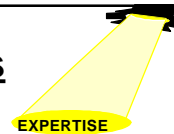

CTA is:

- The description of the cognitive skills needed to perform a task proficiently
- Primarily valuable for tasks that depend on cognitive aspects of expertise, such as decision making and problem solving

KLEIN

ASSOCIATES INC.

Why Don't We Ask?

- We don't know how
- We're afraid to

Nuclear Power Plant Emergency Response Organization (ERO)

(Klinger & Klein, 1999)

Goal: Improve performance of ERO

Approach: Decision-Centered Design

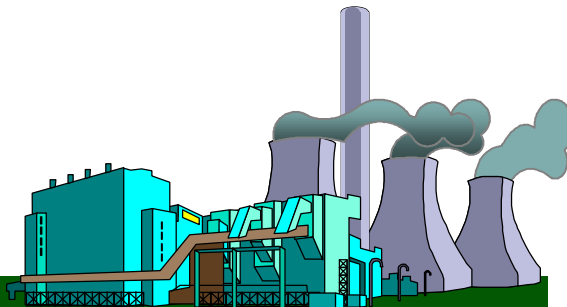

What we did

- Modified room layout
- Quiet, efficient workspace
- Priorities are clear
- Difficult scenarios are easy
- NRC scores up, previous problems dropped
- Expertise is exposed
- Clarified roles and functions using low fidelity simulations
- Reduced staff size from 80 to 35

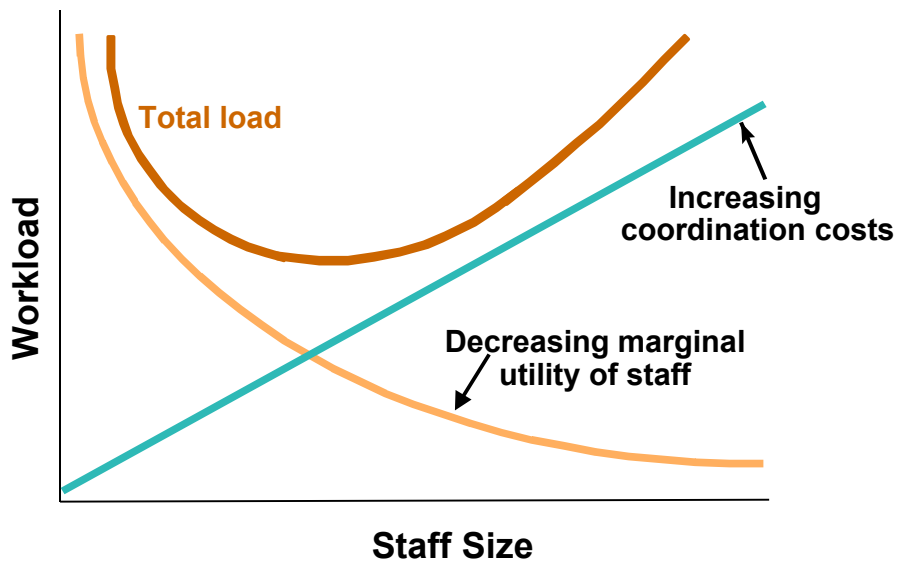

Conclusions:

$$1 + 1 < 1$$

- **The whole can be less than the sum of its parts**
- **Information technologies can support expertise—or interfere with it**
- **Designers have to focus on key decisions**
- **Designers have to support expertise**

KLEIN

ASSOCIATES INC.

(Intentionally blank)

The Role of Decision-Support in Logistics Command and Control

Michael J. Badger

Command and Control Directorate

CECOM



The Role of Decision Support in Logistics Command & Control (Log C2)

Michael J. Badger, C2D, CECOM
(732) 532-0492
DSN 992-0492
E-mail: badger@mail1.monmouth.army.mil

The Army Vision

Soldiers on Point for the Nation
Persuasive in Peace;
Invincible in War

- *1 Bde in 96 hrs*
- *1 Div in 120 hrs*
- *5 Divs in 30 days*

- **Responsive**
- **Deployable**
- **Agile**
- **Versatile**
- **Lethal**
- **Survivable**
- **Sustainable**

- Increase Strategic Responsiveness
- Improve Operational Jointness
- Develop Leaders for Joint Warfighting and Change
- Complete Full AC / RC Integration
- Man Warfighting Units
- Provide Well-Being of Soldiers, Civilians and Families
- Help Soldiers Achieve Goals

CECOM Bottom Line: The Soldier

Log C2 ATD Supports Army's Vision

Logistics C2
(Log C2) ATD

- ✓ Supports JV 2010 and AV 2010 concept of Focused Logistics
- ✓ Binds CSS and the Operational Planning together
- ✓ Shortens CSS planning to within Force XXI one hr planning cycle
- ✓ Provides new automated planning tools for commanders
- ✓ Facilitates the right CSS data, to the right person, at the right time

CECOM Bottom Line: The Soldier



Decision Support is focused on shaping the future



"It's tough to make predictions, especially about the future."

Yogi Berra



REQUIREMENTS

- Data
- Information & Knowledge
- Vision → Mission objectives
- Values

CECOM Bottom Line: The Soldier



The Army's Tactical Need

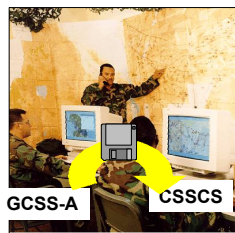

Lack of automated data access

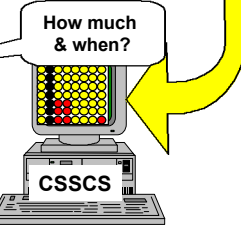

Lack of automation of logistics staff activities:

- Emergency Evacuation
- Reconstitution
- Crewing
- Enemy Prisoner of War
- Decontamination
- Resupply
- Evacuation
- Civil Affairs
- Weapon System Mgmt
- CSS Destruction Plan
- Mortuary Affairs

CECOM Bottom Line: The Soldier

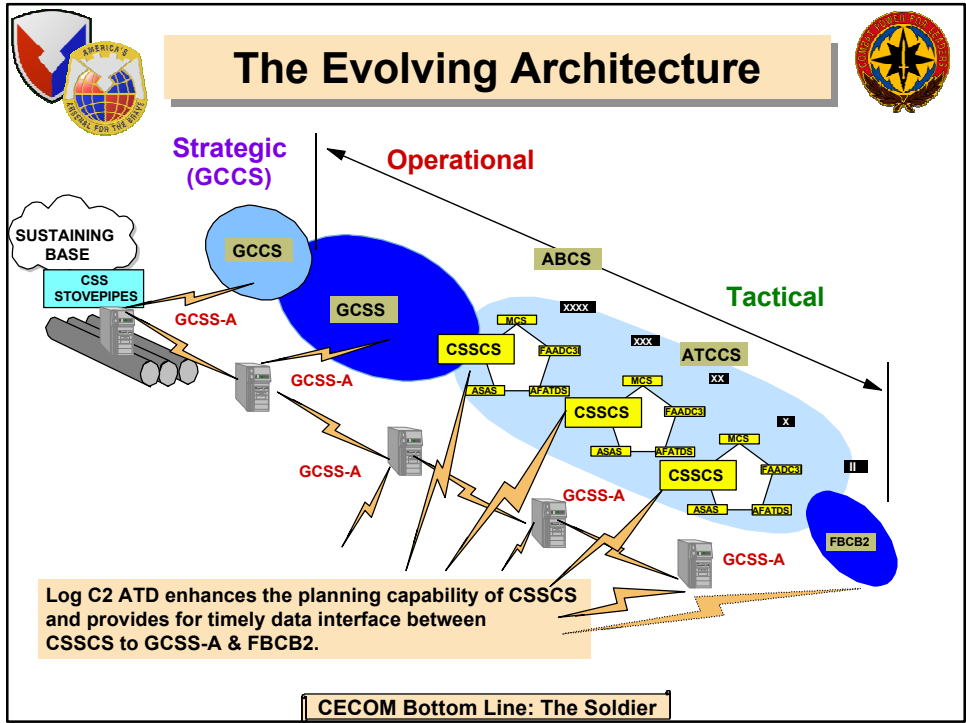

Real Time C2 for CSS Events

Sensors report system health

FBCB2

GCSS-Army
Rev/sec
Temp
Particulate
Time

CSSCS

CHARACTERISTICS

- Intelligent Agents using to perform data mining, alert services, and adaptive planning
- Provided CSSCS the ability to spawn agents to monitor the Joint Common Database (JCDB)
- Collaboration, visualization, COA development and analysis, knowledge creation, execution monitoring and rapid replanning

144

CECOM Bottom Line: The Soldier



Technological Approach



- **Applications will be inherently collaborative**
modular, scalable, distributed, cross-platform, dynamically configurable, web enabled
- **Maintain a clear separation between data, user interface, rules**
- **XML as the primary representation of data for both persistence and messaging (collaboration)**
- **XSL documents for transforming data to HTML/XML**
- **User Interface in Microsoft Foundation Classes**
- **Collaboration Server in Java**

CECOM Bottom Line: The Soldier



DAVINCI Architecture

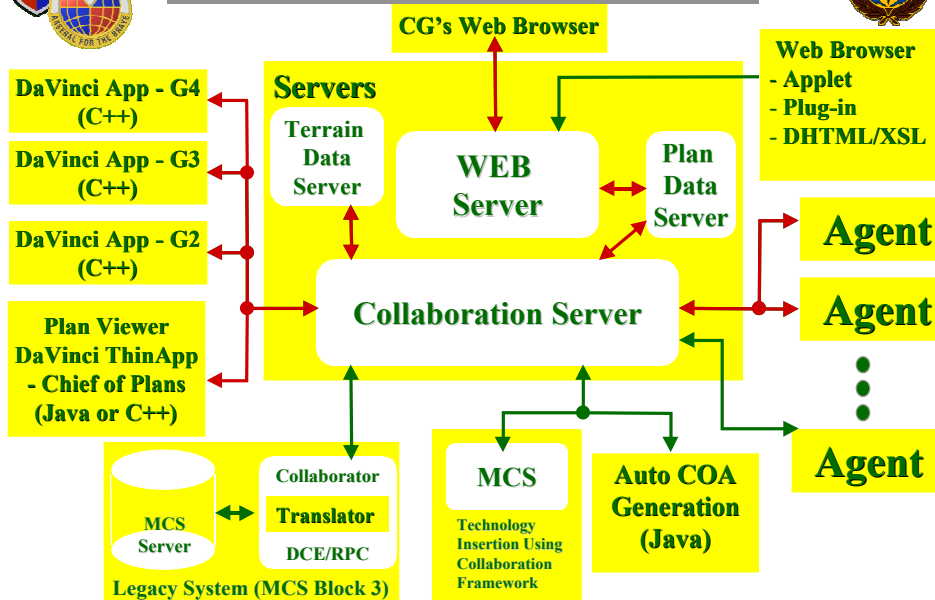

CECOM Bottom Line: The Soldier



Goal: Decision Support for CSS Staff and Commander



Course Of Action (COA)

Develop log support plan in 1-3 hours or less utilizing intelligent agents providing automatic "alert" capability to identify potential log problems

- Diverted shipments (redirected by senior mgmt) or delayed shipments
- Battlefield losses (e.g., NBC, mines, casualty)

Automatic Reconstitution Process Enhancement

- Planning
- Coordinating
- Executing
- Evaluating

Current Process



- CSS staff respond within 4 -8 hours with the feasibility of 3 COAs given by Cmdr
- No automated ability to perform reconstitution

Log C2 ATD

- 1- 3 hours to create COA while using intelligent agents that search the network & alert commander/staff of events and conditions impacting CSS
- Reconstitution optimization software (hosted on CSSCS)

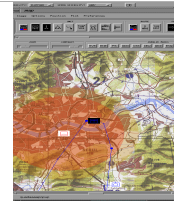

- examples:
- Delayed shipments
 - Battle loss
 - MSR interdictions

CECOM Bottom Line: The Soldier



Visualization and Plan Object Model

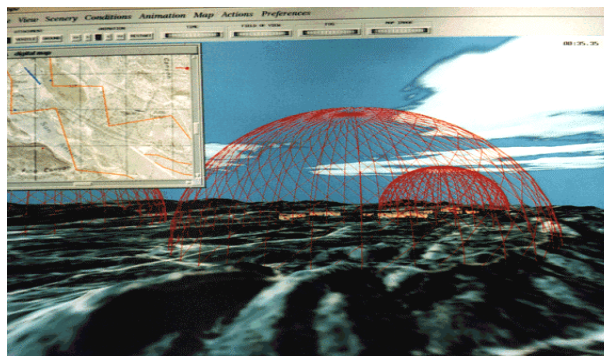

- Leveraged the Course of Action (COA) generation & collaboration software initiated under the Battle Planning Science & Technology Objective and Battlefield C2 ATD
- Currently collaborating with the Command Post XXI ATD by developing the logistics functionality and views for cross-BFA/cross-echelon planning
- Demonstrated JAVA version collaborating with installed versions over a wireless LAN using notebook PC's, NT desktops and SUN workstations on 16 Nov 99

CECOM Bottom Line: The Soldier

Goal: Decision Support for CSS Staff and Commander

CSS SOURCE DATA AUTOMATION

Suite of decision aid software (commanders' decision tool bag) hosted on CSSCS

- Access to essential, timely, and accurate data from multiple data sources
- Eliminate ambiguous data
- Few keystrokes, written commands or voice commands to achieve decision
- Minimize human staff assessments for commander's decisions
- Improve decision cycle process for commanders
- Reduce risk associated with commander's decisions (increase confidence level)

• Commanders either do not have access to necessary CSS data or have no automated tools to perform the following functions:

Current Process

- Maneuver Cmdr
- Emergency evacuation
 - Crewing
 - Mortuary affairs
 - Civil affairs
 - Enemy POW plan
 - Decontamination
- CSS Cmdr
- Resupply
 - Weapon system status management
 - CSS destruction

Log C2 ATD

- Improving the commander's automated decision tool kit by providing software that creates plans for the following function (each within one hour):
- CSS Cmdr
- Resupply
 - Weapon system status management
 - CSS destruction
- Maneuver Cmdr
- Emergency evacuation
 - Crewing
 - Mortuary affairs
 - Civil affairs
 - Enemy POW plan
 - Decontamination

CECOM Bottom Line: The Soldier

Knowledge Base Development

- Demonstrated TRW's Tactical Standard Operating Procedures' (TACSOP) knowledgebase
- Demonstrated access on 16 Nov 99
- Currently under contract with TRW to develop a CSS knowledgebase for commanders

PLANNING TIMELINE: PLAN BRAVO														
Plan 1	PHASE 1			PHASE 2			PHASE 3			AO				
UNITS	2100	2200	2300	0000	0100	0200	0300	0400	0500	0600	0700	0800	0900	1000
AXIS BLUE			Secure AA	Establish OPs						L D	Enemy Screen			
AXIS BLUE			Road March	Occupy AA						L D	MTC	MTC	Engage Main Enemy Force	
AXIS BLUE			Road March	Occupy AA						L D	MTC	MTC	Engage Main Enemy Force	
AXIS BLUE				GSR (Site)										
AXIS BLUE												Smoke Screen		
MULTI													Recon AO	
AXIS WHITE														
AXIS WHITE														
AXIS WHITE														
AXIS WHITE														
AXIS WHITE														
AXIS WHITE														
AXIS WHITE														
AXIS WHITE														

METT-T WORKSHEET

PLAN 1 AXIS BLUE							
Action	Unit	Time	Reaction	Time Effect	Counter Action	Candidate Unit	Time Required
Movement To Contact	A [SF] 7	0500Z 0600Z	Bridge Out	0500Z 0800Z	Secure Bridge	A [SF] 7	0400Z 0500Z
Engage Main Enemy Force	A [SF] 7	0800Z 1200Z					
Objective	A [SF] 7	1200Z 1300Z					

TACSOP Templates	Actions	METT-T	<p>Action Record</p> <p>Name: SECURE BRIDGE</p> <p>Plan: BRAVO</p> <p>Performing Unit: A [SF] 7</p> <p>Location: 52SBT80000300</p> <p>Start Time: 0400Z</p> <p>End Time: 0500Z</p>	<p>Enemy Reactions/ Contingencies</p> <p>AIR ATTACK</p> <p>ARTILLERY ATTACK</p> <p>BRIDGE OUT</p> <p>AMBUSH</p>
------------------	---------	--------	--	---

CECOM Bottom Line: The Soldier



Goal: Decision Support for CSS Staff and Commander



Data Exchange

Data warehousing seamless interfaces GCSS-A to CSSCS

- Elimination of human intervention in data transfer
- Increases access to real time data

Data transfer from FBCB2 to GCSS-A

- Platform information directly to the automated log system

GCSS-A data replication of joint systems

- Army commanders can make informed decisions based on total CSS picture

Current Process

- Manual updates once every 24 hours from an organization
- Access to one database

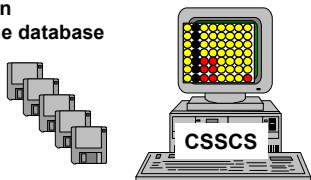

Log C2 ATD

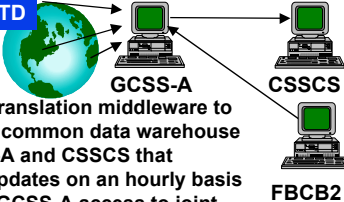

- Provide translation middleware to support a common data warehouse for GCSS-A and CSSCS that enables updates on an hourly basis
- Provide GCSS-A access to joint systems (TC-AIMS II, MC4), Army tactical platforms, and SIDPERS

CECOM Bottom Line: The Soldier



Data Mediation



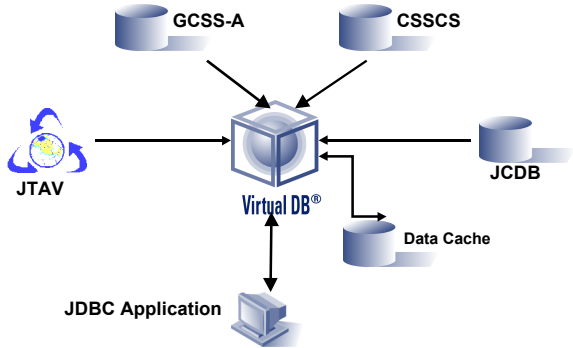

- Provide timely Data Mediation between CSSCS, GCSS-A, and Joint Systems
 - Eliminate Human Intervention for Data Access/Transfer
 - Increase Access to Real Time Data
 - Automated Data Update
- Demonstrated access on 16 Nov 99
- Transitioning initial 'enroute' application to CSSCS on 31 Mar 00 for ABCS 6.1

CECOM Bottom Line: The Soldier

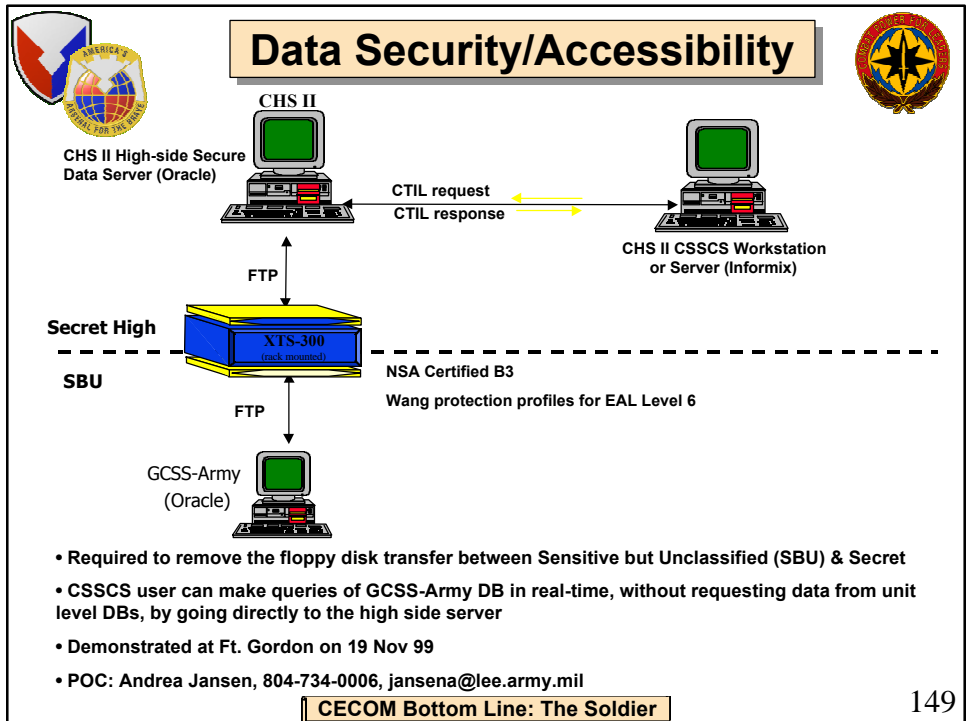
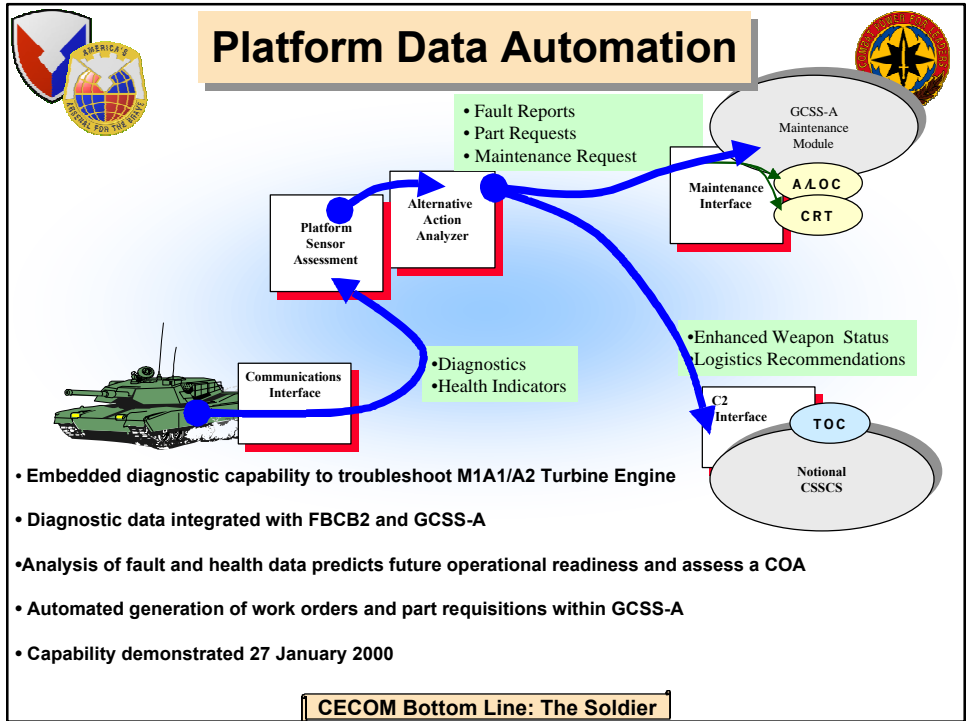



Values: The Missing Link



“A nickel ain’t worth a dime anymore!”

Yogi Berra

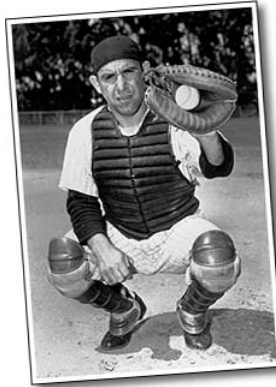

CECOM Bottom Line: The Soldier



Optimization Problem



- Agents must operate within a B2B-type marketplace in which the economic terms are fully understood by all active participants (e.g., dollar, minute, risk, attrition, lift asset)
- Each agent must be capable of tailoring the value placed
- Agents must be capable of being given a priority level based upon the user whose interests the agent represents (e.g., the CG’s agent, the chef’s agent, ...)
- Proximity of planning change to current time is included in the assessment

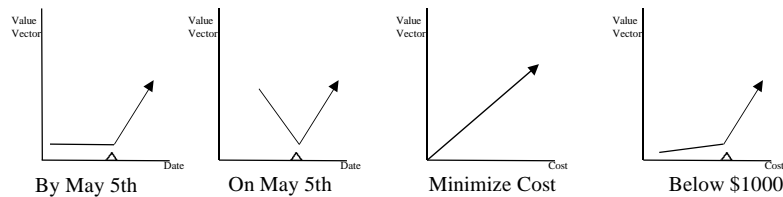



Partial Acronym List



ABCS = Army Battle Command Systems	GCCS = Global Command and Control System
ASAS = All Source Analysis System	GCSS = Global Combat Support System
ATD = Advanced Technology Demonstration	GCSS-A = Global Combat Support System - Army
ATCCS = Army Tactical Command and Control Systems	HTML = Hyper Text Markup Language
AV = Army Vision	JCDB = Joint Command Data Base\
BFA = Battlefield Functional Area	JDBC = Joint Data Base Connectivity
C2D = Command and Control Directorate	JTAV = Joint Total Asset Visibility
CECOM = Communications and Electronics Command	JV = Joint Vision
COA = Course of Action	LAN = Local Area Network
CRT = Combat Repair Team	Log C2 = Logistics Command and Control
CSS = Combat Service Support	MC4 = Medical Communications for Combat Casualty Care
CSSCS = Combat Service Support Control System	MCS = Maneuver Control System
CTIL = Commanders Tracked Item List	TOC = Tactical Operation Center
C4I = Command, Control, Communications, Computers and Intelligence	XML = eXtensible Markup Language
DAVINCI = Distributed Analysis and Visualization Infrastructure for C4I	
FBCB2 = Force XXI Battle Command Brigade and Below	

CECOM Bottom Line: The Soldier

(Intentionally blank)

INFORMATION FOR THE JOINT THEATER DISTRIBUTION SYSTEM

Ms. Virginia Wiggins
Joint C4ISR Decision Support Center

Background

In support of Joint Vision 2010 (JV2010) and the visionary concepts of operations of the Military Services, the ability to provide current, reliable and timely information to enable “Focused Logistics” for the warfighter is paramount.

The Joint Command, Control, Communications, Computers, Intelligence, Surveillance, and Reconnaissance (C4ISR) Decision Support Center’s (DSC) Senior Steering Group (SSG), comprised of the Under Secretary of Defense for Acquisition, Technology, and Logistics (USD(AT&L)), the Assistant Secretary of Defense for Command, Control, Communications, and Intelligence (ASD(C3I)) and the Vice Chairman of the Joint Chiefs-of-Staff (VCJCS) directed the Joint C4ISR DSC to conduct a study on vulnerabilities of Information Assurance (IA) and the Joint Theater Distribution System (JTDS). The fundamental question posed by the SSG was:

“What are the impacts of information warfare operations on the information architecture for the Joint Theater Distribution System being evaluated by the Joint Theater Distribution/Joint Test & Evaluation) (JTD/JT&E) effort?”¹

This fundamental question generated four supporting questions with a fifth question added by Deputy Under Secretary of Defense for Logistics, DUSD(L) after the study start date. These supporting questions were:

What are the key elements of the information infrastructure supporting the Joint Theater Distribution System?

Will the system have the network capacity available for support?

Which of these elements are most vulnerable to disruption or denial of information flow?

What is the impact on combat operations if the Theater Distribution System is disrupted by information warfare?

What strategies can be used to mitigate the impact of information warfare on the Joint Theater Distribution System?²

Providing answers to the Study questions required an in depth review of the JTD/JT&E effort, and the underlying support infrastructures for logistics, and transportation. The JTD/JT&E reengineering activity is focused on in-theater distribution from the air and shipping ports of

¹ Memorandum from Director, Joint C4ISR DSC, June 23, 1998, as approved by ASD (C3I) June 29, 1998, USD(A&T) July 13 1998 and VCJCS September 17, 1998.

² Added by Deputy Undersecretary of Defense for Logistics (DUSD(L))

debarcation (APODs and SPODs) to a central distribution point. It is currently focused on defining the "AS IS" architecture and in examining what changes can be implemented to improve distribution processes in theater. The JTD/JT&E are essential to addressing some of the process issues that are currently in theater. The JTD/JT&E does not, and is not, required to address the global issue of information assurance and the end-to-end impacts of information warfare on the logistic system.

As the DSC team evaluated the scope of Joint Theater Distribution, it was determined that to fully assess information assurance, a global holistic approach had to be applied with specific considerations given to: number of systems, global connectivity, private industry interactions, technology migration, people, processes, policy, procedures, laws and investments. This approach allowed the team to consider the implications for JV2010 and the full spectrum of the Focused Logistics mission.

Time and resource limitations required the study team to make maximum use of available information from CINC/Service and /Agency (C/S/A) subject matter experts and their activities. These activities included but were not limited to; the Deputy Under Secretary of Defense for Logistics (DUSD(L)) calendar year 2000 (Y2K) testing, Department of Defense (DoD) Inspector General (IG) audits and analyses, Defense Intelligence Agency (DIA) and Joint Task Force (JTF)-Computer Network Defense (CND), Service wargaming, and Service scenario efforts. Representatives from the C/S/As were participants in these efforts.

The study was complemented by a Senior Review Group (SRG) that included two former CINCs, a former Director of DIA, a former Director of DLA, a former Deputy ASDC³I, the former Commander of Army Material Command, and several former Service Operational Commanders.

In completing the study, the team developed several products used to support the analysis, which were used by contemporary efforts, and can be used by future efforts. These products included: Final Report and Briefing

A threat and risk analysis methodology

A methodology to link Logistics information flow to combat outcomes

A database providing detailed information on operational information flows and Information Exchange Requirements for Logistics processes

A database providing information on logistics and transportation nodes and systems deployed world wide

Findings

The Study effort resulted in four general findings and numerous specific ones related directly to the Study questions.

General Findings

General Finding 1:

An end-to-end analysis of the logistics process was required to assess Information Assurance (IA) implications. The extent to which the DoD's logistic and transportation community is integrated with international and domestic commercial communications, manufacturing, and service industries is a dominant factor in assessing IA.

Figure 1 displays the end-to-end processes required to execute Joint Theater Distribution. Shaded areas representing non-government owned suppliers, transportation, and communications requiring full integration and harmonization.

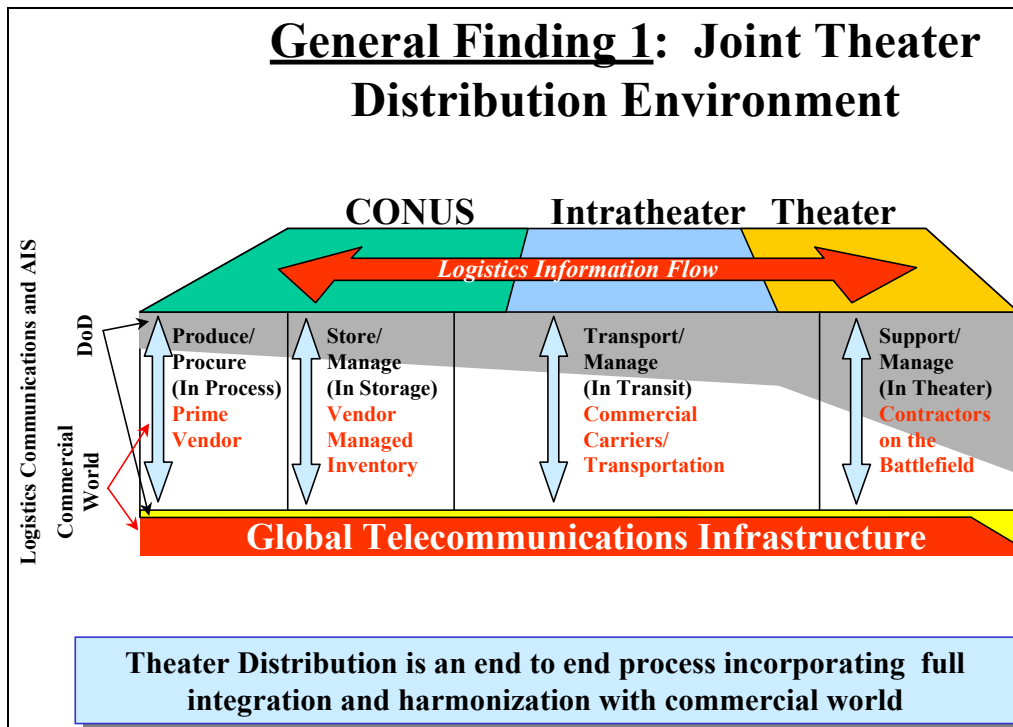

Figure 1. General Finding 1.

General Finding 2:

Since the end of the Cold War the logistics “mass” necessary for combat has been drawn down significantly, and further draw downs are planned. This has resulted in a decrease in the robustness of our combat logistics capability. In order to execute Focused Logistics the DoD must be able to replace the need for mass with information. Such a change requires improvement in automated capabilities and training. The increase in automated processes and the associated training will allow for the necessary information flow, management data, and IA to realize Focused Logistics as envisioned in JV 2010. In order to execute focused Logistics as envisioned in JV 2010, the DoD must be able to move the necessary information (shown as the blue dashed line in Figure 2.) Logistics capabilities must be sufficiently agile to compensate for lack of mass.

In Figure 2, the red line reflects the mandated drawdown of DoD logistics support capabilities. The blue line represents the required reliance on Information Technology to include Information Management and Information Assurance. It is the opinion of the study team that uninterrupted information flow is critical to the ability of US forces to sustain operations as envisioned in JV 2010.

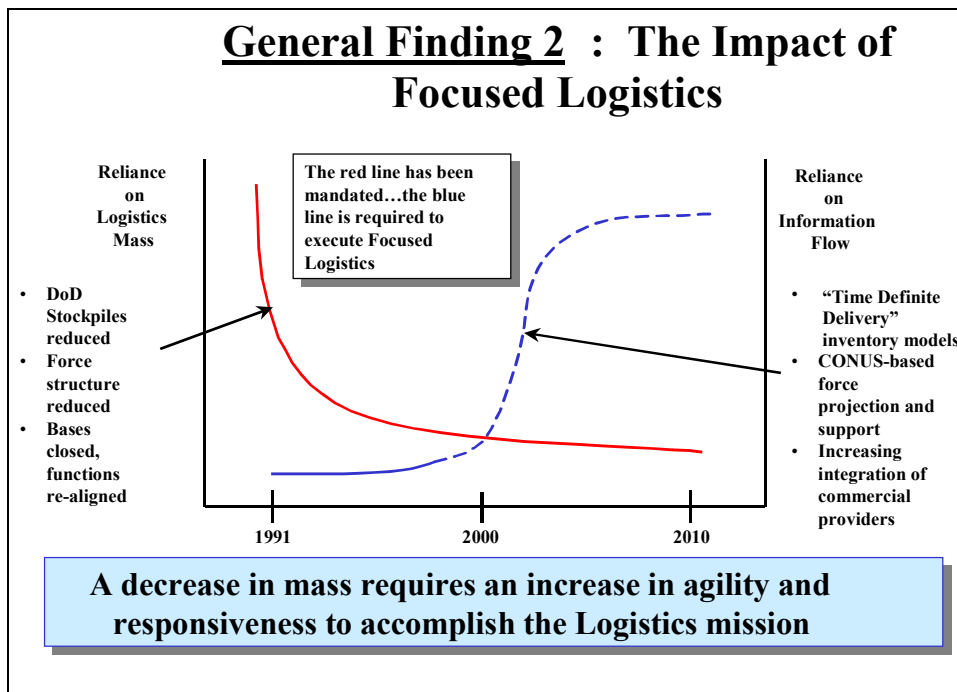

Figure 2. General Finding 2

General Finding 3:

The nature and extent of the threat to DoD information assurance is rapidly growing in both quantity and quality. Research conducted by the team clearly indicates that the potential threat spans a wide spectrum of sources from casual hackers to state players. In addition, the nature of the threat has grown increasingly sophisticated, resulting in a constant race between attackers and the means to defend against them. It should also be noted that attacks have become increasingly sophisticated, resulting in operational impacts, not just “cosmetic” damage to Web sites.

Figure 3 summarizes the reported and projected attack on DoD information systems as reported by the US General Accounting Office and by other sources.³

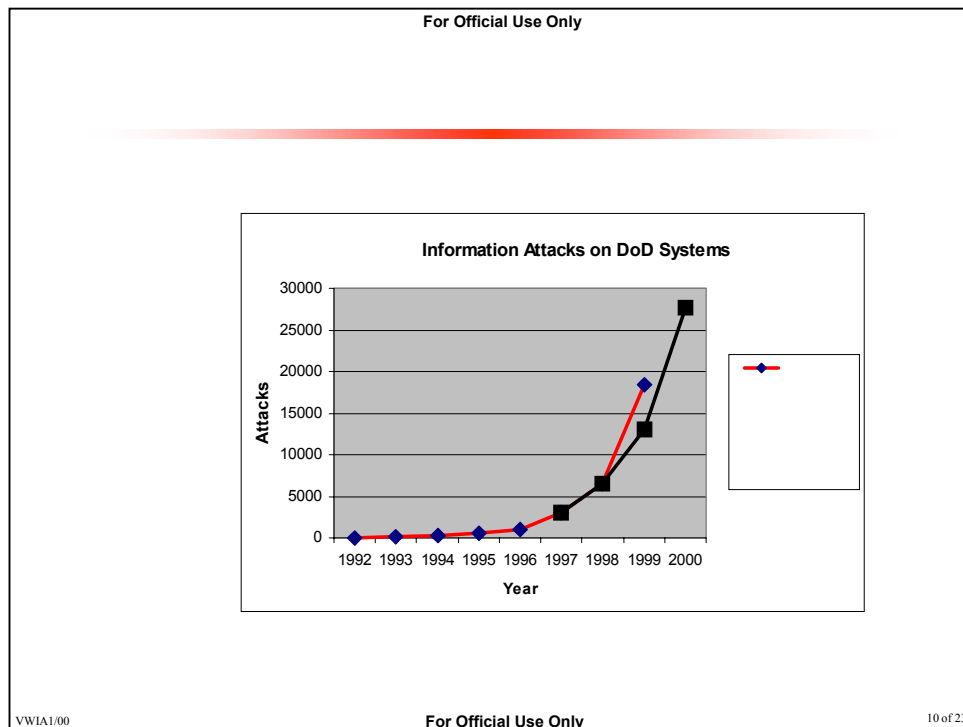

Figure 3. General Finding 3

General Finding 4:

There is no clear and concise overarching DoD policy or guidance for IA. The many ongoing activities within DoD in the logistics functional area are continuing without benefit of understanding how they fit in the larger picture and thus will not achieve the level of IA necessary to accomplish the long-term goals established by senior leadership. It would appear that a program to overcome this condition would include a centralized management structure similar to the recently successful Y2K undertaking with the understanding that the changing threat environment will necessitate it remain in place in some form over time. Participation will be required from all organizations involved with DoD logistics.

Specific Findings

Question 1: What are the key elements of the information infrastructure supporting the Joint Theater Distribution System?

- Finding: While there are several key elements that may be more important than others, the interdependency of logistics information flows makes it difficult to focus on just a few.

³ GAO/AIMD-96-84 Information Security Computer Attacks at Department of Defense Pose Increasing Risks, and Federal Computer Week, 20 December, 1999.

Interdependency means that there are “no service unique systems”. In order for any service to requisition a part, on average, at least two services and one agency are required. The logistics environment is large, complex and information intensive with no coherent operational architecture or protection mechanism. An operational baseline is needed in order to manage changes or additions.

Question 2: Will the system have the network capacity available for support?

- Finding: Review of planned communications capacity and infrastructure, in conjunction with the emerging doctrine for logistics, indicated that capacity in theater at the tactical level, the so called “last mile,” is (and is likely to remain) an issue.

Question 3: Which of these elements are most vulnerable to disruption or denial of information flow?

- Finding: Vulnerabilities vary with situation, attack strategy and requirements. The logistics community is “inextricably linked” to the global information infrastructure (including the Internet) and commercial enterprise. Technology velocity is a key factor and, therefore, vulnerabilities are dynamic. Threats can be multi-dimensional, and can evolve rapidly. Thus, the very nature of the logistics informational process may result in significant and substantial vulnerabilities that may change over time.

Question 4: What is the impact on combat operations if the Theater Distribution System is disrupted by information warfare?

- Finding: Assured information is critical to the ability of the forces to execute Focused Logistics. Modeling and Simulation analysis of the Major Regional Conflict (MRC) Scenario named Lantica (adopted from the Army) provided insight into the potential combat impact. In sum, after fifty excursions for each of five test cases, disruptions in information flow led to longer engagements at higher costs. Those costs were in the form of human casualties, vehicle losses, and conflict duration. Simulation results indicated that, with information delays of up to 5 days over the base case, losses increased by a factor of 2 over those in the base case. With information delays of 30 days (an assumed upper boundary) losses increased by a factor of six (6) over the base case. Significantly, in that upper boundary case (30 day delay), US forces were unable to defeat the opposing force in 30% of the trials run.

Question 5: What strategies can be used to mitigate the impact of information warfare on the Joint Theater Distribution System?

- Finding: Given the time and resources allotted, the Study was unable to develop any specific mitigation strategies. Nevertheless, insight into the process revealed that logistics IA must include both network defense and defense in depth at the information element level. The team found that current strategies focus on just two steps (provision of policy and site specific accreditation) in what must be a multi step process. The result is a potentially significant gap in our overall mitigation strategies. In order to answer the question of a

specific set of mitigation strategies, a "next step" for the logistics community needs to be defined. A risk analysis must be performed identifying threat impact, cost of mitigation, information criticality, operational constraints, and time impact.

Overall, Logistics IA is a C4I class problem. The solution must include consideration of Operational Architectures, Threat Assessment, Return on Investment, Certification, People, Policies, Processes, Procedures, Technology, Law and Investment (See Figure 4).

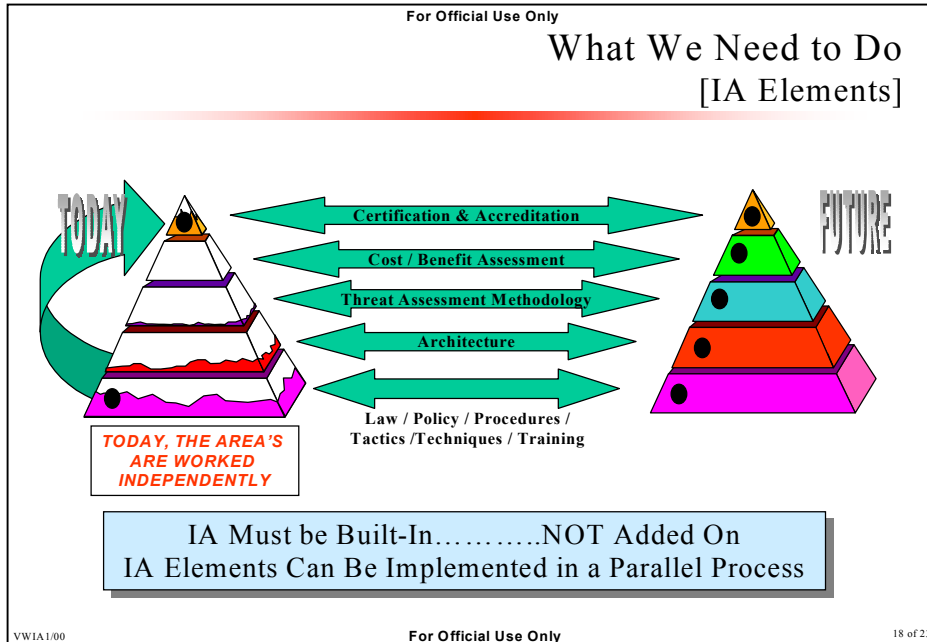

Figure 4. What We Need to Do

Conclusions

Information Assurance is critical to the successful conclusion of battle in the JV 2010 environment. Absence of Information Assurance could be a "War Stopper". Attaining Information Assurance will require leadership focus at least equal to the efforts taken to resolve the Y2K phenomena with the understanding that continuous attention will be required as the threat and technology change over time. The IA threat/decision space must be determined and corrective action prioritized. (See Figure 5).



Defense in Depth and the IA Decision Space

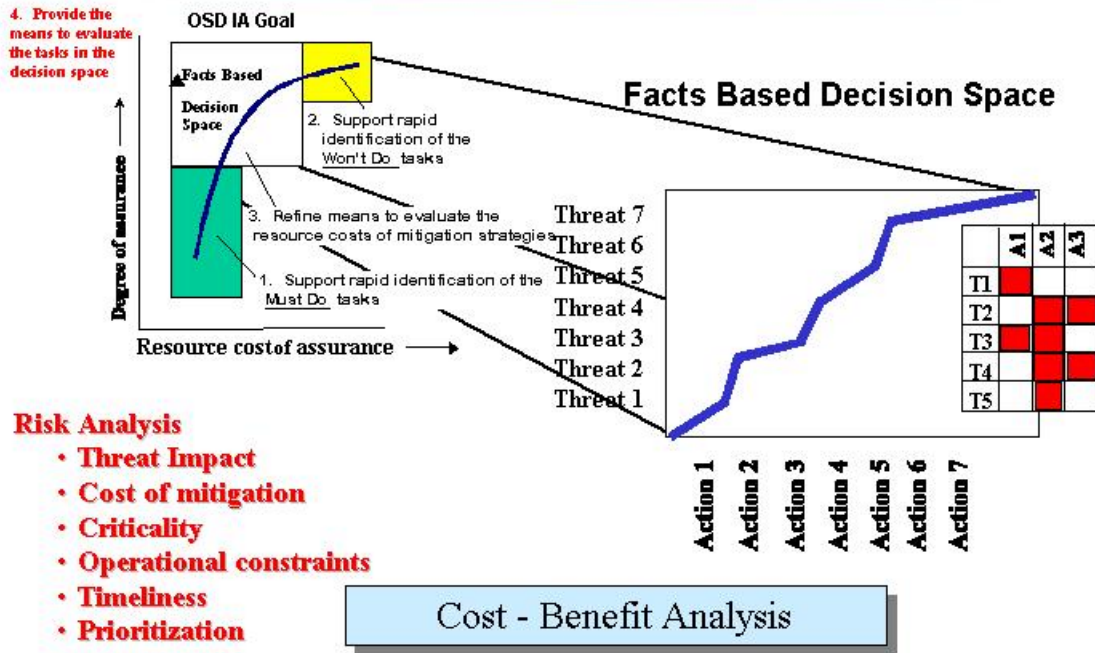

VWIA100

1 of 24 **Figure**

5. Defense in Depth and the Information Assurance Decision Space

Recommendations

DoD should manage the Logistics IA effort with aggressiveness and attention comparable to that given the Y2K effort . To do this, DoD must:
Establish methodology for mitigation alternatives applicable to all functional areas.

Develop actionable steps for logistics IA.

DoD should define a “next step” for the DoD community:

Must support definition and bounding of the Logistics Information Assurance decision space

Must include mechanism for evolution, evaluation of IA strategies

Operations, Intelligence, Logistics, Finance, Policy,

Air, Land, and Sea Combatants ...

Modeling & Simulation (Red on Blue)

DoD should establish an Executive Agent and **implement** the following:

Near Term: (next 18 months) Develop the Process

Immediate DoD level effort to develop comprehensive multi-disciplined logistics IA Plan which sizes the problem, defines the decision space, identifies high payoff mitigation

alternatives...based on documented operational architecture. Redefine Logistics functions and Structure to include IA capabilities?

Include a technical architecture and implementation plan (Standards).

Establish a mechanism for continuous and comprehensive threat projection vice historical reporting.

Establish and apply a DoD managed mechanism for mission driven, red on blue assessment of IA solutions for the logistics architectures to support the planning effort.

Develop investment alternatives to support integration of logistics IA effort into overall DoD planning.

Consolidate Policy (Laws) and Directives (Reduce to a minimum set).

Conduct laboratory and operational experiments to investigate and evaluate mitigation strategies (Modeling and Simulation).

Conduct training (Architecture, Information Assurance/Security).

Mid Term: (18-24 months) Apply the Process

Apply the plan to Logistics efforts underway (i.e. JTDS/JT&E Test cases).

Continue laboratory and operational experiments to investigate and evaluate mitigation strategies.

Establish training programs to develop Information Management Staffs. The training should include training in architectures, information management, and information assurance/security.

Long Term: (>24 months) Institutionalize the process

Tie to the JWCA and POM process.

The process will be iterative due to the changes in technology, policies and doctrine.

Information Assurance and Joint Theater Distribution System Vulnerabilities

Virginia Wiggins, Study Director
Joint C4ISR Decision Support Center
Office of the Assistant Secretary of Defense for
Command, Control, Communications, and Intelligence
(OASDC3I)



DoD Perspective: Infrastructure and Information Assurance

Mr. Richard Schaeffer
Director, Infrastructure and Information
Assurance
OASD (C3I)

Presented by:
Ms Virginia Wiggins
Joint C4ISR Decision Support Center



OASD(C3I) Organization

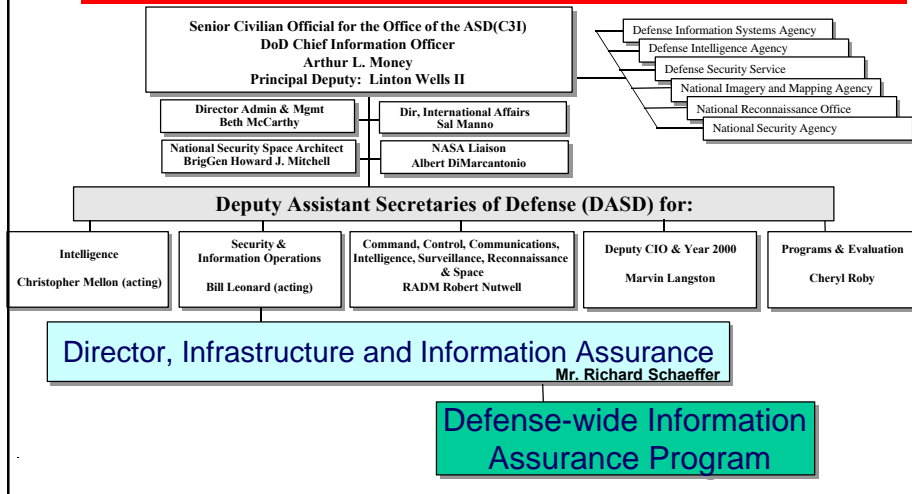

Elements of Information Assurance

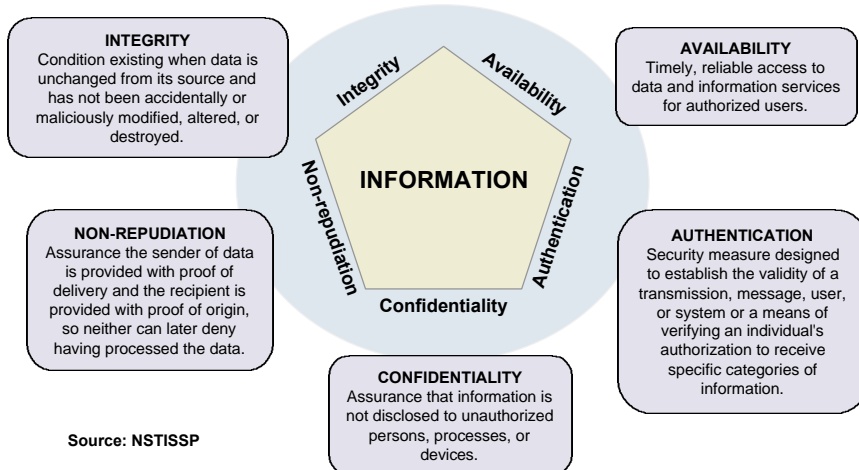



Threats & Vulnerabilities

>> Threats

- ⇒ Natural
- ⇒ Environmental
- ⇒ Human Intentional
- ⇒ Human Unintentional

>> Vulnerabilities

- ⇒ Physical
- ⇒ Environmental
- ⇒ Hardware
- ⇒ Software
- ⇒ Media
- ⇒ Network/ Communications
- ⇒ Procedural



DoD IA Goal

Ensure DoD's vital information resources are secure and protected

Ref: DoD CIO October 1999, *DoD Information Management (IM) Strategic Plan* (ver 2.0)



Operational Readiness

Protect Detect Respond

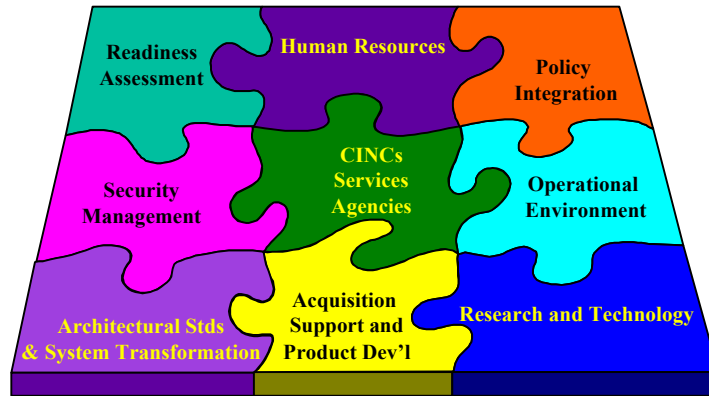

(Intentionally blank)



Joint C4ISR
Decision Support Center
Study 99-5:
Information Assurance and Joint Theater
Distribution System Vulnerabilities
Executive Information Briefing

Ms. Virginia Wiggins
DSC Study Director
E-mail: Virginia.Wiggins@osd.pentagon.mil
703.607.0604



Topics

- Who We Are
- What We Studied
- What We Found
 - The Joint Theater Distribution Environment
 - The Impact Of Focused Logistics
 - The Threat
- What We Learned
- Why This Is Important To You
- What We Need To Do
- How We Need To Approach The Task



Joint C4ISR Decision Support Center Mission

- **Organizational Relationship:** An OSD organization, JC4ISR, DSC is tasked by a Senior Steering Group comprised of the VCJCS, USD (A,T,&L), and ASD/C3I.
- **Mission:** The JC4ISR Decision Support Center is tasked to provide decision makers with analytic support for establishing requirements, acquiring and fielding C4ISR systems.
- JC4ISR DSC Director, Col David Komar



What We Studied

Information Assurance to execute Focused Logistics and Joint Theater Distribution

DSC tasked to conduct study to address the following questions:

- *What are the key elements of the information infrastructure supporting the Joint Theater Distribution System?*
- *Will the system have the network capacity available for support?*
- *Which of the key elements are most vulnerable to disruption or denial of information flow?*
- *What impact on combat operations if the Theater Distribution System is disrupted by information warfare?*
- *What strategies can be used to mitigate the impact of information warfare on the Joint Theater Distribution System?*

Study required rapid look at complex and extensive community



What We Found

- Q1-Logistics Environment: large, complex, information intensive, with no coherent operational architecture or protection mechanisms
- Q2-Capacity: capacity to support logistics at the pointy end of the spear is...and will remain...an issue
- Q3-Vulnerability: logistics community is “inextricably linked” to global information infrastructure (including the Internet) and commercial enterprise...technology velocity a key factor
- Q4-Combat impact: assured information is critical to ability of forces to execute focused logistics...disruptions lead to longer fight at higher cost
- Q5-Strategy: network defense is necessary, but **not** sufficient...strategy must be a **defense in depth** based on **information** defense
- Q5-Policy: many policies...no clear guidance or well understood strategy

Logistics IA is a C4I class problem; approach must include consideration of People, Policies, Processes, Procedures, Law, and Investment



What We Found

Joint Theater Distribution Environment

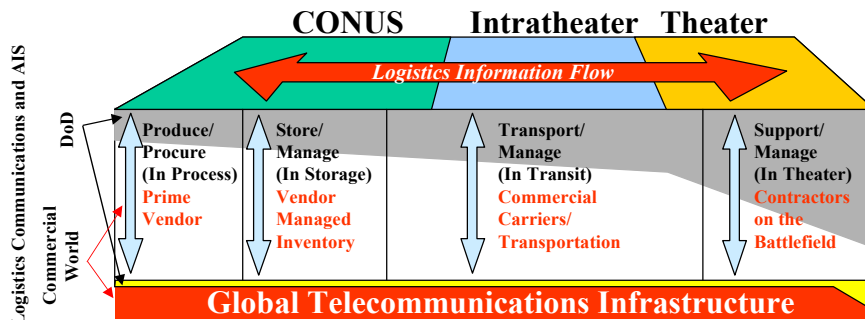

Theater Distribution is an end to end process incorporating full integration and harmonization with commercial world

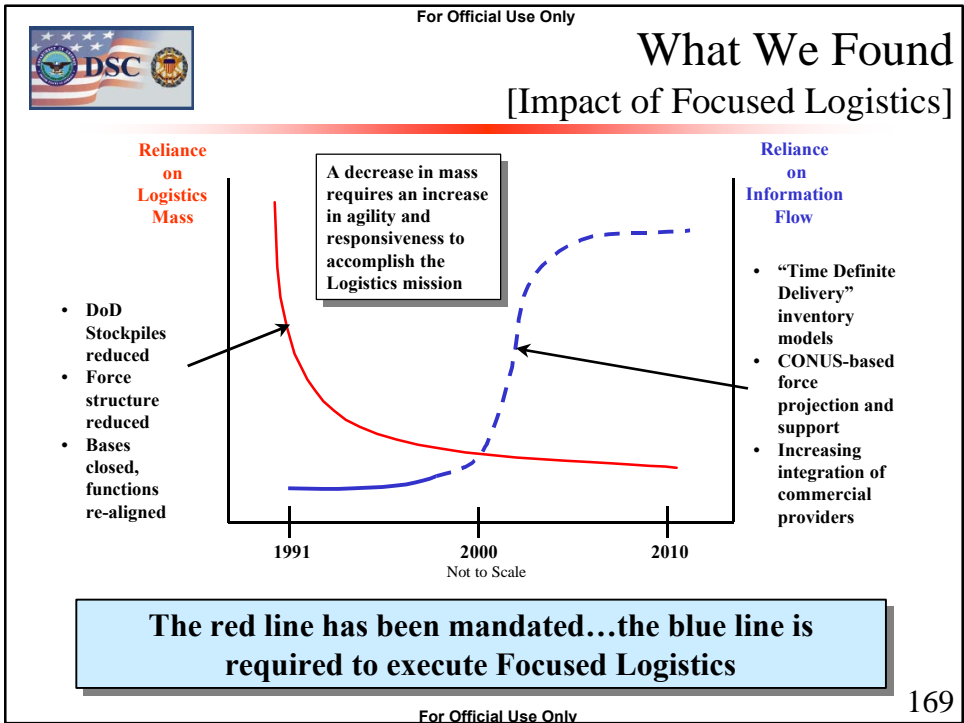
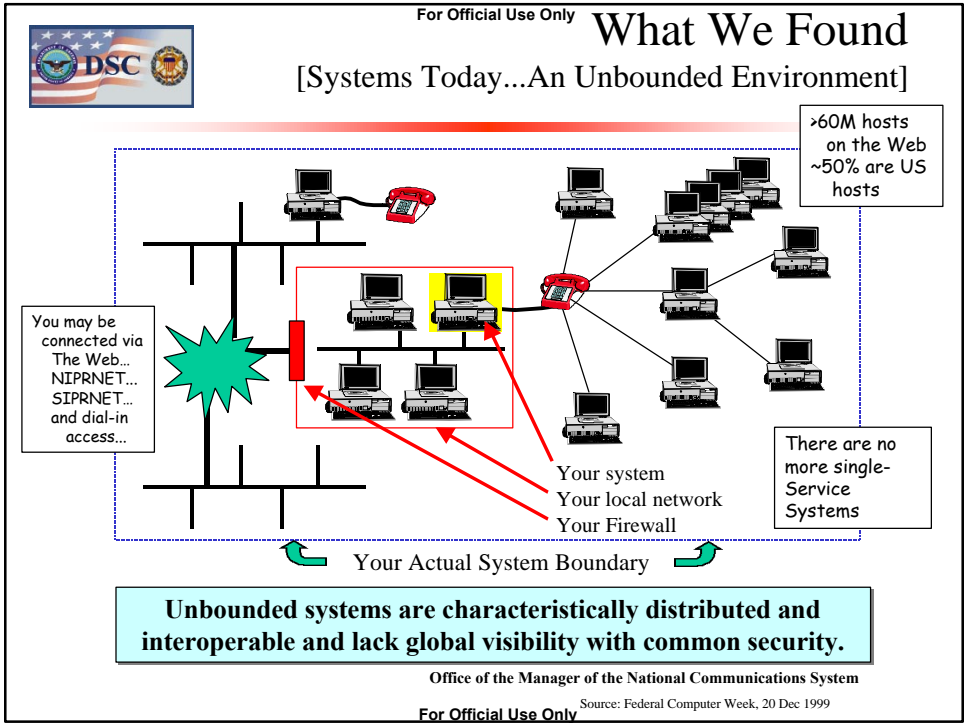



What We Found

[The Threat...Now]

Your DoD Information System in FY 00:

- Will experience **Unauthorized Access**.
- Will experience **Unauthorized Manipulation** of its information
- Will experience **Denial of Access**.
- And critical decision support capabilities will be **Disrupted, Delayed or Disabled**.

Your information is no more assured than the weakest link in your information chain

Source: Federal Computer Week, 20 Dec 1999, CERT Advisories



What We Found

[The Increasing Level of Attack]

Attacks increased by approx. 300% from 1998 to 1999

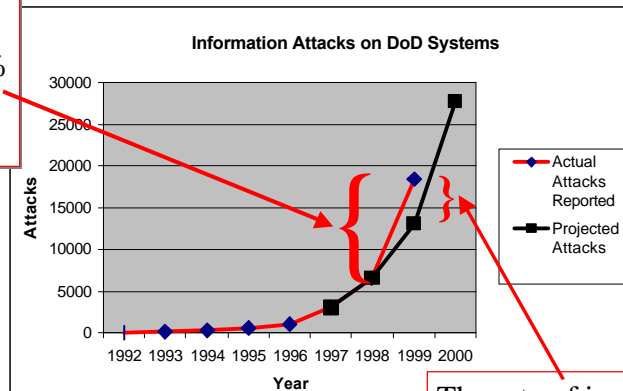

Source: Projections - GAO/AIMD-96-84
1998 to 1999 Increase - Federal Computer Week, December 20, 1999

The rate of increase was approx. 150% of that projected



What We Found [Simulation Results]

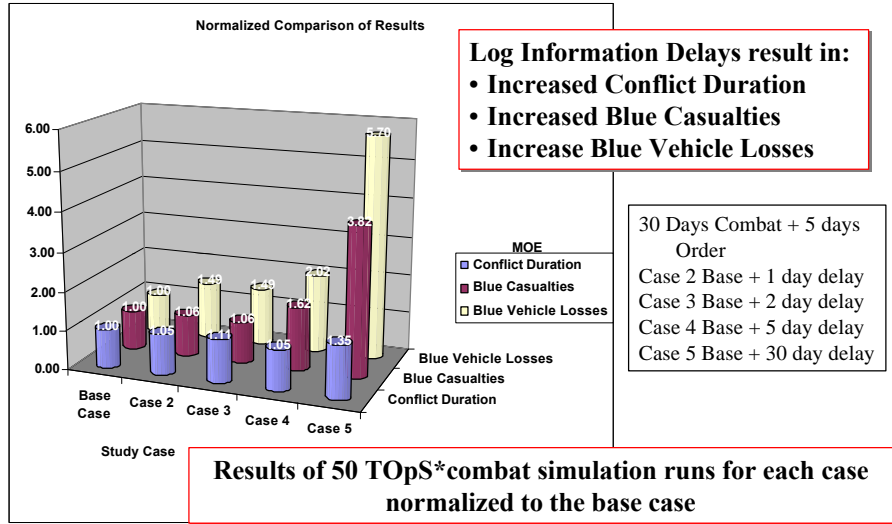

* Theater Operation Simulation (US Air Force) -Red / Blue force mode
For Official Use Only



What We Found (Policy and Guidance)



Policy and Guidance

- Exists from national level down to services and agencies
- Is not fully coordinated
- May be selectively applied

Varying applications of policy by services and program managers are likely to require some level of mediation



What We Learned

- Log systems can be disrupted at various levels
- There will be a combat impact
- The players are NOT just state players anymore
 - Motivation & Capability determine extent of impact

There is NO item of information that is 100% secure 100% of the time... If someone wants it, it can and will be obtained...

Source: The Sword & Shield: The Mitrokhin Archive and the Secret History of the KGB, by Christopher Andrews and Vasili Mitrokhin, Published 1999



Why Is It Important

- Focused logistics...critical to operations of US forces
- Assured information...critical to execution of focused logistics
- Logistics “inextricably linked” to global information infrastructure
- Agility, flexibility, robustness required to meet threats have to have ability to evolve quickly /smartly
- Information-centric defense-in-depth key to assured information, agility, flexibility and robustness

Global, Holistic Approach



What would a bounded Decision Space contribute to the Logistics IA Objective?

4. Provide the means to evaluate the tasks in the decision space

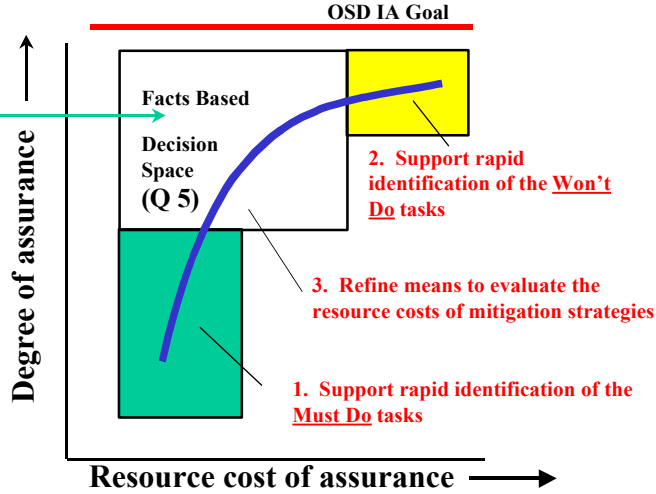

What is the Return on Investment?



What Is Required [Defense In Depth]

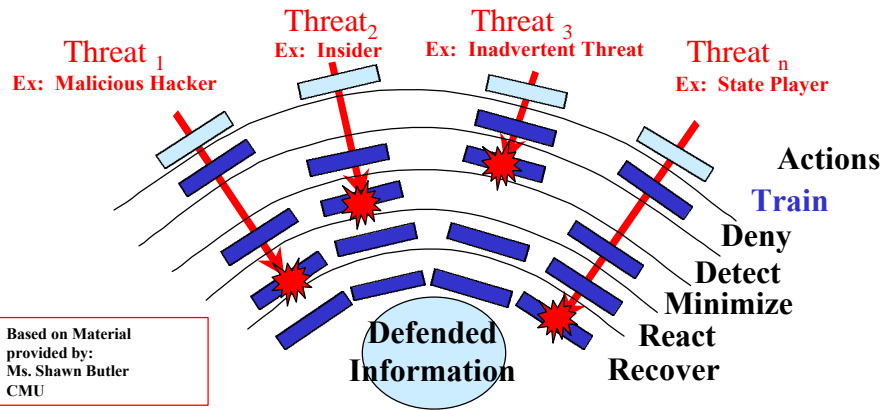

Based on Material provided by: Ms. Shawn Butler CMU

- Systems approach to defense of resources, including information elements
- Tailored to anticipated threats to resources
 - Intelligence driven, not just event based
- System Level cost benefit analysis for defense mechanisms



Defense in Depth and the IA Decision Space

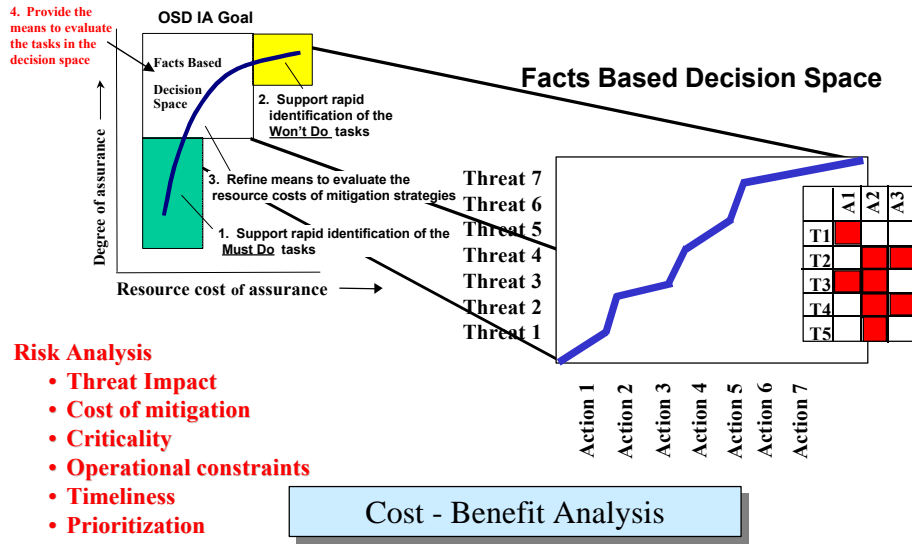

IA Elements

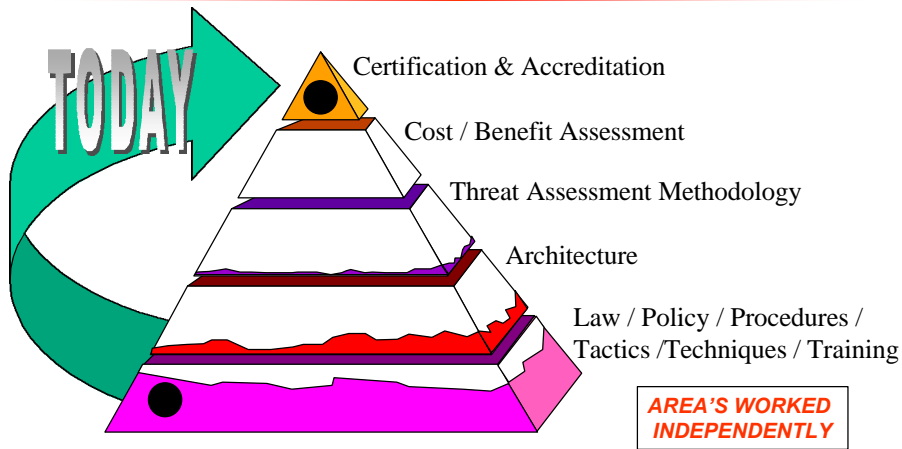

IA Must be Built-In.....NOT Added On
IA Elements Can Be Implemented in a Parallel Process



Study Recommendations

DoD should:

- **Manage** the Logistics IA effort with aggressiveness and attention comparable to that given the Y2K effort
- **Define** a “next step” for the DoD community:
 - **must support definition and bounding of the Logistics Information Assurance decision space**
 - **must include mechanism for evolution, evaluation of IA strategies**
 - **Operations, Intelligence, Logistics, Finance, Policy, Air, Land, and Sea Combatants ...**
 - **Modeling & Simulation (Red on Blue)**

The IA challenge CAN be successfully addressed



Required Actions

- **NOW Community Needs to Decide on a Follow-on Effort (Not a Study)**
- **Near Term (next 18 months): Develop the process to ensure Logistics IA for legacy and new systems**
- **Mid Term (18-24 Months): Apply the process**
- **Long Term (>24 Months): Institutionalize the process**

Develop Process, Apply Process, Institutionalize the Process in a Global Holistic Approach

Computational Intelligence for Decision Support

Russell C. Eberhart, Yaobin Chen, and Jinchun Peng
Purdue School of Engineering and Technology
Indiana University Purdue University Indianapolis

Introduction

Several analytic tools have matured recently that facilitate solving problems that were previously difficult or impossible to solve. Included are evolutionary computation, artificial neural networks, and fuzzy systems. Combinations of these new analytic tools among themselves, as well as with more traditional approaches, are collectively known as *computational intelligence*, and are being used to solve extremely challenging problems. Computational intelligence applications typically require a small fraction of the time of other approaches to develop prototypes and applications. The resulting systems are robust with respect to noise, missing data, etc., and often run significantly faster than systems built using other approaches (Eberhart *et al.* 1996).

This paper discusses the application of computational intelligence to decision support systems (DSSs). One definition of a DSS is that it is an interactive, flexible, and adaptable computer-based information system specially developed for supporting the solution of a non-structured management problem for improved decision making. It uses data, provides easy user interface, and can incorporate the decision maker's own insights. In addition, a DSS may use models, is built by an interactive process (often by end-users), supports all phases of decision making, and may include a knowledge component (Turban and Aronson 1998). Stated more succinctly, the goal of a DSS is to provide useful knowledge at a glance (Wood 1999).

This paper begins by reviewing the field of computational intelligence and its constituent methodologies. We review the concepts of evolutionary computation, artificial neural networks, and fuzzy logic, emphasizing the use of evolutionary computation as the foundation of our approach to computational intelligence. We then briefly look at the concept of swarm intelligence, taking a brief tour through relevant paradigms of social psychology before discussing the particle swarm optimization algorithm.

Next, we examine computational intelligence algorithms and implementations applicable to DSSs, starting with the more general topics of evolving neural networks and evolving fuzzy systems and ending with a practical example of using evolutionary computation to optimize shipping container movements at an integrated automated container terminal.

Finally, we indulge in some speculations regarding future work. We see exciting possibilities in both research and applications.

1 Computational Intelligence and its Components

Before discussing computational intelligence itself, it is logical to briefly examine each of its main constituent methodologies: evolutionary computation, artificial neural networks, and fuzzy logic. A definition is offered for each, and examples of application areas are listed. For more detailed analyses and information, refer to (Eberhart *et al.* 1996).

1.1 Computational Intelligence Component Methodologies

Evolutionary computation (EC) comprises adaptive optimization and classification paradigms roughly based on mechanisms of evolution such as natural selection and self-organization. The evolutionary computation field includes genetic algorithms, evolutionary programming, genetic programming, evolution strategies, and particle swarm optimization.

Primary application areas of EC include:

- Optimization: finding the best possible solution to a complex problem (often NP hard) in the specified time.
- Classification: operating in multiple-fault dynamic environments.
- Explanation: providing explanation facilities for systems such as complex artificial neural networks

We view evolutionary computation as providing a foundation for computational intelligence. It seems to us to be in some sense the mortar that holds the bricks together. All of our recent applications involve evolutionary algorithms *plus* other components; the evolutionary paradigm is always present.

An artificial neural network (ANN) is an analysis paradigm that is roughly modeled after the massively parallel structure of the brain. It simulates a highly interconnected, parallel computational structure with many relatively simple processing elements (PEs) (Eberhart *et al.* 1996). ANNs are able to approximate any non-linear function to any specified degree of accuracy.

Primary application areas of ANNs include:

- Classification as reflected in decision theory: determining which of a set of predefined classes best represents an input pattern.
- Associative memory: obtaining an exemplar pattern from a noisy and/or incomplete one.
- Clustering, or compression: significantly reducing the dimensionality of an input.
- Control systems: modeling a non-linear system as well as designing the control system.
- Simulation: generation of structured sequences.

Fuzziness refers to nonstatistical imprecision and vagueness in information and data. Fuzzy sets model the properties of imprecision, approximation, or vagueness. In a fuzzy set, fuzzy membership values reflect the membership extents (or grades) of the elements in the set. Fuzzy

logic comprises operations on fuzzy sets, including equality, containment, complementation, intersection, and union; it is a generalization of crisp (two-valued) logic.

Primary application areas of fuzzy systems include:

- Control systems: controlling complex systems in real time.
- Fuzzy expert systems: providing support in diagnostic and decision support systems

1.2 Computational Intelligence

Computational intelligence is a process or methodology involving computing (usually involving a computer) that exhibits an ability to adapt to new situations, and/or to self-organize, such that the system is perceived to possess attributes such as reason, decision, prediction, implication, and intention. Capabilities of a system with computational intelligence may include generalization, discovery, abstraction, and/or association. Put another way, computational intelligence comprises practical *adaptation and/or self-organization* concepts, paradigms, algorithms, and implementations that enable or facilitate intelligent behavior in complex and changing environments.

Computational intelligence systems in silicon often comprise hybrids of paradigms such as artificial neural networks, fuzzy systems, and evolutionary computation systems, augmented with knowledge elements. Computational intelligence silicon-based systems are often designed to mimic or augment one or more aspects of carbon-based biological intelligence.

Figure 1 illustrates the relationships among intelligent system components. The shading of individual process blocks roughly indicates the level of computational intelligence present. As can be seen, the highest concentration of computational intelligence generally exists in the adaptation and self-organization process.

Inputs to the intelligent system from the environment can be sensory inputs in the case of biological systems or data in the case of a silicon-based system. The intelligent behavior output includes communications to, and actions upon, the environment. Intelligence is as intelligence does. If there is no action or communication that affects the environment, there is no intelligent behavior.

Primary data flows are represented by the thick arrows. The sensing and pre-processing area outputs pre-processed data. In addition to reactions (discussed below), outputs of the processing and algorithms process include processed data, clusters, classes, and features. Outputs of the adaptation and self-organization area where the bulk of the system's computational intelligence resides include decision, prediction, reason, intention, and implication.

The world model contains the knowledge that the system has about the world, or environment, as the name implies. Included in the world model are such things as data, survival information, available resources information, culture, goals, values, and adaptation strategies. Between the world model and each of the four process areas is a two-headed dotted arrow, signifying a flow of "information" or "knowledge" in both directions. The sizes of the arrowheads are meant to

very roughly reflect the relative quantities of the flows. For example, the flow *from* sensing and pre-processing *to* the world model is much greater than the flow *to* sensing *from* the world model. A greater proportion of the flow, however, goes *from* the world model *to* the output generation area than vice versa.

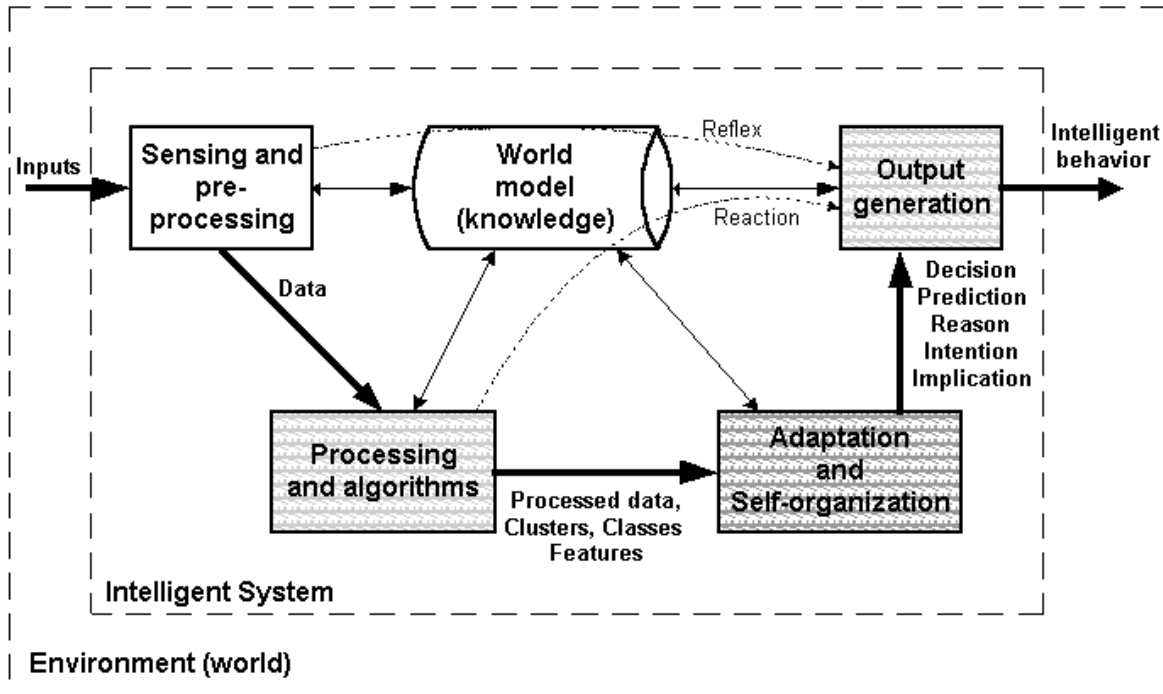

Figure 1. Relationships among components of intelligent systems; shading roughly indicates computational intelligence level.

One dotted arrow goes from sensing to intelligent behavior; another goes from processing and algorithms to intelligent behavior. These represent processes leading to actions related to safety and survival. An example of a reflex is an action such as a person makes upon touching a hot stove. An example of a reaction is the process you'd go through if you opened your front door and found a Bengal tiger staring you in the face.

Figure 1 is meant to convey the belief that there is no distinction between carbon- and silicon-based intelligence. A system simply possesses one or more of the attributes illustrated, and the actions on and communications to the environment are intelligent to some degree, depending on system attributes. Computational intelligence is buried within the core of the system, be it animal or machine. It is generally removed from the interface with the environment. It is an area in which developments are rapidly occurring that are resulting in exciting new analytical tools.

2 Swarm Intelligence and Particle Swarm Optimization

In this section we describe a recently developed evolutionary computation paradigm called particle swarm optimization. It was developed by Jim Kennedy, a social psychologist, and Russ Eberhart, an engineer. The paradigm has roots in computer science, psychology, and artificial life.

Evolutionary computation is discussed in the previous section. In this section, we first take a brief tour of social psychology paradigms that have provided the underpinnings of the swarm intelligence concept. For a more detailed account, see (Kennedy *et al.* 2000). Three social psychology paradigms directly fed into swarm intelligence, although others also played roles. They are Latané's dynamic social impact theory, Axelrod's culture model, and Kennedy's adaptive culture model.

Latané's dynamic social impact theory asserts that the behaviors of individuals can be explained in terms of the self-organizing properties of their social system, that clusters of individuals develop similar beliefs, and that subpopulations diverge (polarize) from one another. In summary, it says that individuals influence one another, and in doing so become more similar, and that patterns of belief held by individuals tend to correlate within regions of a population. This model is consistent with findings in the fields of social psychology, sociology, economics, and anthropology.

In Axelrod's culture model, populations of individuals are pictured as strings of symbols, or "features." The probability of interaction between two individuals is a function of their similarity, and individuals become more similar as a result of interactions. The observed dynamic is *polarization*, homogeneous subpopulations that differ from one another.

Kennedy's adaptive culture model makes important revisions to the above approaches. For example, there is no effect of similarity on the probability of interaction. Rather, interaction occurs if *fitnesses* are different. In fact, the effect of similarity is negative in that it is *dissimilarity* that creates boundaries between cultural regions.

So, what do we learn from all this that we can apply to swarm intelligence and particle swarm optimization? A brief summary of culture and cognition relevant facts is that:

- Individuals searching for solutions learn from the experiences of others (individuals learn from their neighbors)
- An observer of the population perceives phenomena of which the individuals are the parts (individuals that interact frequently become similar)
- Culture affects the performance of individuals that comprise it (individuals gain benefit by imitating their neighbors)

Now that we've completed our brief tour of social psychology, we move into the area of swarm intelligence and particle swarms. For our purposes, a *swarm* is an apparently disorganized collection (population) of moving individuals that tend to cluster together while each individual seems to be moving in a random direction. We also use *swarm* to describe a certain family of social processes.

Particle swarm optimization is a paradigm for optimizing nonlinear functions. It was developed by Jim Kennedy and Russ Eberhart (Kennedy and Eberhart 1995, Eberhart and Kennedy 1995). It is simple in concept, easy to implement, computationally efficient, and effective on a wide variety of problems. It is related to bird flocking, fish schooling, and swarming theory. It is also an evolutionary algorithm, with some similarities to genetic algorithms and evolution strategies.

The particle swarm population is initialized by assigning random positions and velocities to each population member (particle). Potential solutions are then flown through hyperspace. Each particle keeps track of its "best" (highest fitness) position in hyperspace. This is called *pbest* for each individual particle, *gbest* for the best in the population (when a global model is used), and *lbest* for the best in a defined neighborhood (when a neighborhood model is used). At each time step, each particle is stochastically accelerated toward its *pbest* and *gbest* if the global model is used, or *pbest* and *lbest* if a neighborhood model is used. The neighborhood comprises the particle and a selected number of its topological neighbors. For example, a neighborhood of five includes the particle and its two topological neighbors on each side.

The particle swarm optimization process is as follows:

1. Initialize the population in hyperspace.
2. Evaluate the fitness of individual particles.
3. Modify the velocity of each particle based on its *pbest* and *gbest* (or *lbest*).
4. Terminate on some condition.
5. Go to step 2.

The velocity and position update equations for the global version of particle swarm optimization are

$$v_{id} = w_i v_{id} + c_1 \text{rand}() (p_{id} - x_{id}) + c_2 \text{Rand}() (p_{gd} - x_{id})$$

$$x_{id} = x_{id} + v_{id}$$

where d is the dimension, c_1 and c_2 are positive constants, $\text{rand}()$ and $\text{Rand}()$ are random functions, and w is the inertia weight. (For the neighborhood version, just change p_{gd} to p_{ld} .)

The performance of each particle is measured according to a predefined fitness function. The inertia weight influences the tradeoff between global and local exploration. A common approach is to reduce the inertia weight during a run (*i.e.* from 0.9 to 0.4 over 1000 iterations), to set c_1 and c_2 to about 1.5 or 2.0, and to set the maximum allowable velocity V_{max} to the dynamic range of each variable (on each dimension).

We can now define an *intelligent swarm* as a population of interacting individuals that optimizes a function or goal by collectively adapting to the local or global environment. Put concisely, *swarm intelligence = collective adaptation*.

3 Applying Computational Intelligence to Decision Support

In order to be useful to decision makers, decision support systems should meet four criteria (Wood 1999). They should satisfy a compelling need in a complex decision situation, provide useful assistance in the user's context, be collaborative, and be adaptive.

Computational intelligence can play a role in all four criteria. In fact, as we have seen, the essence of computational intelligence is adaptation, and the essence of particle swarm optimization is collaboration. The methodologies described in this paper thus focus primarily on the third and fourth criteria, which have to do with how decision support systems are designed to function internally.

In this section, we present two general approaches to applying computational intelligence: evolving artificial neural networks and evolving fuzzy expert systems. We then conclude the section with an example of a computational intelligence application to a decision support system: the planning of shipping container moves in an integrated automated container terminal.

Neural networks are very good at solving some problems, such as mapping input vectors to output vectors. Evolutionary algorithms are very good at other problems, such as optimization. It should not be surprising, therefore, that hybrid tools can be developed that are better than either approach by itself. Using an evolutionary algorithm such as particle swarm optimization, we can evolve not only the weights but also the structure of artificial neural networks.

The approach can be used with virtually any artificial neural network structure. It thus is logical to evolve neural networks capable of being universal approximators, such as back-propagation and radial basis function networks. In back-propagation, the most common processing element (PE) transfer function (the calculation carried out at each hidden PE of the network) is the sigmoid function, $output = 1 / (1 + e^{-input})$. Eberhart *et al.* (1996) were the first to use particle swarm optimization (PSO) to evolve artificial neural network weights, thus replacing the back-propagation algorithm. But PSO can also be used to indirectly evolve the structure of a network. An added benefit of this approach is that the scaling or normalization of input data is made unnecessary.

In this approach, PSO is used to evolve both the network weights *and* the slopes of the sigmoid transfer functions of hidden (and output, if used there) PEs. If we now consider the transfer function to be $output = 1 / (1 + e^{-k*input})$, then we evolve k in addition to evolving the weights. The method is general, and is applicable to other network topologies and transfer functions. Flexibility is gained by allowing slopes to be positive or negative. A change in the sign of a slope is equivalent to a change in the signs of all of the input weights to that PE.

The structure is evolved as follows. If the evolved slope for a hidden PE is sufficiently small, the sigmoid output can be clamped to 0.5, and the hidden PE can be removed. The network weights from the bias PE in the hidden layer to each PE in the next layer are increased by one-half the value of the weight from the PE being removed to the next-layer PE. PEs can thus be pruned, reducing network complexity. If the evolved slope is sufficiently high, the sigmoid transfer function can be replaced by a step function. This is used for either large negative or positive slopes. This method is also applicable in an analogous way to output PEs with sigmoid transfer functions. The network computational complexity is thus reduced. Since transfer function slopes can evolve to a wide range of values, it has been found that input normalization is generally not needed. This significantly simplifies the applications process and shortens

development time. The PSO process acts on the network structure in a relatively continuous way, so that no sudden discontinuities exist such as those that plague other network evolution approaches. For more details regarding the use of PSO to evolve artificial neural network structures, see Kennedy *et al.* (2000).

Fuzzy expert systems are widely used for applications such as control and diagnosis. For fuzzy systems, however, the generation of the fuzzy rules and fuzzy membership functions typically is difficult. The number of possible fuzzy rules increases exponentially with the number of variables. Therefore, efficient methods are needed to automatically design fuzzy expert systems for complex applications such as decision support. The system hypersurface is generally complex, multi-modal, and non-differentiable, making evolutionary algorithms good candidates.

The method used to evolve fuzzy expert systems involves evolving (adapting) fuzzy membership functions and rules to achieve acceptable system performance. The first important consideration is the representation strategy: all information about the rule set and membership functions must be encoded. We often encode the entire fuzzy system into a string of integers, including the number of rules used, the rule set, and the membership function types, shapes, and ranges. Prior to the evolution process, we often cluster inputs using a neural network paradigm such as learning vector quantization or fuzzy min-max clustering. We then use the evolutionary algorithm, such as PSO or a genetic algorithm to evolve the fuzzy system. While running the algorithm, fuzzy rules are used to adapt the parameters of the evolutionary algorithm.

This, then, is an example of a computational intelligence tool in which all three major component methodologies play an essential role. Fuzzy expert systems evolved using this approach typically outperform those using other approaches, and have significantly more compact rule sets. Furthermore, development time is significantly faster. For more details on this approach, see Shi *et al.* (1999).

Finally, we consider the design of integrated automated container terminal facilities. This approach has the potential to increase the throughput of container ports by 50 percent. Our objective is to develop planning and scheduling algorithms for these facilities. Our approach is to use a computational intelligence tool that combines fuzzy logic and evolutionary programming. A typical two-berth facility was used for our proof of concept.

An evolutionary programming method was employed to optimize container handling operations. Different from common evolutionary programming methods, the mutation in the proposed method is strongly yard-oriented. In principle, a yard operation system may be regarded as a discrete event system. One operation (move) of a container causes its state to change. Because the minimum move sequence can't be determined in advance, the problem space has to be expanded with the optimization process. This expansion is implemented with one loop of the optimization program. In general, the initial value of the space dimension is the number of the related containers. Another optimization objective is to minimize the buffer spaces. However, sometimes the original problem has no solution if too few buffer spaces are allowed. In our program, we use another loop to achieve this. The buffer number increases from one to the maximum available value.

The core of this optimization method is evolutionary computation. It is worthwhile to point out that the objective of the evolutionary programming phase is different from the overall optimization process. Evolutionary programming is used to judge if a move sequence with a given length exists that correctly implements the state transition, not to minimize the number of moves. However, the combination of the evolutionary programming and loops achieves the overall objective of maximizing the efficiency of the system. For every given move sequence length m , we may set a limit to the number of the evolution generations. Whenever the proper action sequence is found within the maximum allowed generations or whenever the generation limit is reached although no goal result is obtained, the current evolutionary process terminates. Generally, the smaller m is, the larger the limit that is set and vice versa.

Simulation results reveal that this method is effective and efficient. For example, for 250 containers that arrive through a truck gatehouse, our method can be used to intelligently stack them once in an intermediate area, then move them to the berth-side (water-side) yard ready for loading exactly according to the vessel stowage plan. The final move to berth-side can typically be done in 256 moves (for a total of 506 moves, counting the pick and place operations from the arriving trucks to the intermediate stack), and the planning for this operation using our algorithm takes less than 30 seconds. While some aspects of this methodology are proprietary, additional information can be found in Peng *et al.* (2000).

4 Future Activities

In research, we are looking forward to working in at least three areas. First is the development of metrics for decision support systems that can be applied in a real-time mode. For example, determining optimal patterns of the Kolmogorov-Sinai entropy for system development and operation seems promising. Second, we are looking at ways to incorporate self-organization into systems design. Self-organization is being increasingly recognized as an essential element of evolution. Whereas evolution has been viewed as primarily comprising the process of natural selection (in a neo-Darwinist sense), it is becoming increasingly recognized that self-organization plays an important role: *evolution = natural selection + self-organization*. Third, we are investigating the real-time tracking of nonlinear dynamical systems using computational intelligence. It seems possible that we may even be able to track chaotic systems, within limits.

In applications, we continue to work in the area of advanced transportation decision support systems. We are beginning work on the second phase of the Integrated Automated Container Terminal automated planning system, and hope to apply our expertise and methodologies to problems of interest to the Office of Naval Research. We are also continuing our work in the medical diagnostics area. The future look bright!

Acknowledgments

Portions of this paper on swarm intelligence and particle swarm optimization were adapted from a book entitled *Swarm Intelligence* being published later this year by Morgan Kaufmann Publishers; we thank them for their kind permission to use the material. With respect to the

container handling example, the input and support of Mr. Dan Reiss and his organization, Automated Terminal Systems, is gratefully acknowledged.

References

Bezdek, J.C. (1998); Computational intelligence defined – by everyone!; Computational Intelligence: Soft Computing and Fuzzy-Neuro Integration with Applications (ed. O. Kaynak, L.A. Zadeh, B. Törkçen, and I.J. Rudas), Springer Verlag (pp. 10-36)

Eberhart, R.C. and J. Kennedy (1995); A New Optimizer using Particle Swarm Theory; Proc. Sixth Intl. Symposium on Micro Machine and Human Science (Nagoya); IEEE Service Center, Piscataway, NJ (pp. 39-43)

Eberhart, R.C., Simpson, P.K. and R.W. Dobbins (1996); Computational Intelligence PC Tools; Academic Press

Kennedy, J. and R.C. Eberhart (1995); Particle Swarm Optimization; Proc. IEEE Intl. Conf. on Neural Networks; IEEE Service Center, Piscataway, NJ (pp. IV:1942-8)

Kennedy, J., Eberhart, R. C., and Y. Shi (2000); Swarm Intelligence; Morgan Kaufmann Publishers (in press)

Peng, J., Chen, Y., and R.C. Eberhart (2000); An Efficient Scheduling System for Container Terminal Yard Management using Evolutionary Programming; Proc. 6th Intl. Conf. on Information Systems Analysis and Synthesis, Orlando, FL (in press)

Pohl, J. (1999); Collaborative Decision-Support and the Human-Machine Relationship; Proc. A Decision-Making Tools Workshop, Office of Naval Research (pp. 21-46)

Shi, Y., Eberhart, R. and Y. Chen (1999); Implementation of Evolutionary Fuzzy Systems; IEEE Transactions on Fuzzy Systems, Vol. 7, No. 2 (pp. 109-119)

Turban, E. and J.E. Aronson (1998); Decision Support Systems and Intelligent Systems; Prentice-Hall (p. 77)

Tuttle, J. (1999); A Personal Perspective on Decision Makers and Their Decisions; Proc. A Decision-Making Tools Workshop, Office of Naval Research (pp. 1-7).

Wood, A. (1999); The Components of the “Decision Industry;” Proc. A Decision-Making Tools Workshop, Office of Naval Research (pp. 9-20)

Sponsored by the Office of Naval Research (ONR)

ONR Decision-Support Workshop Series

The Human-Computer Partnership in Decision-Support

Section Two: *Open Forum Seminars*

Theme A: *Expeditionary Command and Control (C2) Users*

1. Differing User Group Requirements

A key capability of collaborative agent-based systems is their potential to discipline the decision environment, filtering the extraneous, clarifying the situation, and offering alternatives. However, user environments differ radically (e.g., a mobile infantry squad in an urban battlefield versus a fixed logistics staff aboard ship). Should we develop a matrix of user requirements (e.g., small units to large ones, dismounted infantry to pilots)?

2. Customization of the User-Interface

‘Scalability’ of collaborative decision-support systems can be defined as the need to provide appropriate scope to address what is really important to the users at each level within the organization. This is normally defined in advance by the commander. ‘Tailoring’ on the other hand, can be defined as providing the capability to each user to specify the of information needed and the manner in which it is to be displayed. This is more commonly left to the individual user. ‘Functionality’, actions that the system is authorized and required to perform under certain conditions, is less clearly defined. While broad performance parameters are set in a top down fashion during system design and later, there is an increasing requirement to give the individual user the capability to create ‘custom agents’ (i.e., specific system capabilities) to assist in narrowly defined areas. What considerations should apply here?

3. Free Format Text and Voice Recognition

Text-to-voice and voice-to-text capabilities are becoming more and more reliable. How can these capabilities be employed to enhance understanding and accelerate decision tempo within the contemporary operations center? Can they contribute in an archiving context? Have they a role in alerts and warnings? Can these capabilities be joined with agent functions to pass information to units that do not possess an electronic data capability (e.g., automatically translating an agent visual alert to voice and passing it over an FM radio to a field unit)?

4. Rapid Objectification of Infrastructure Data

The most sophisticated collaborative agent-based systems generate maps and various ‘views’ directly from the object model. However, there will be only limited time to develop a rich object model in a short warning contingency. Further, NIMA data may be lacking or incomplete for the contingency area of operations (e.g., West Africa). What ‘off-the-shelf’ tools and methods should be developed in order to ‘objectify’ aerial photos, construction data, commercial map information, etc.? Can extant GIS products be used to complement the ‘objectified’ aspects in order to rapidly produce a more complete and useful graphic reference for the user?

5. Formalizing the Data Objectification Process

There is a requirement to continuously enrich and expand the object model. Should a permanent staff responsibility be established for this function (e.g., the ‘OM section, G-2’) or should it be handled in another fashion?

6. Human Decision Making Skills and the Role of Training

A collaborative decision-support system requires the active participation of the human user at the higher levels of the decision making process. This places capability requirements on the user that users may not be adequately prepared for. What particular decision making skills are necessary and useful for the effective utilization of collaborative decision-support systems? How can the performance of human decision makers be improved through formal training methods?

Discussion Items:

Initial issue – **verification of data**. Can the commander trust the data that are being acquired? The conversion of data into information can lead to serious misinterpretations. Users will not use a decision-support system unless they have confidence in the performance of the system. In this regard decision-support systems must have fairly deep explanation facilities (e.g., what is the next best recommendation and how close is it to the best recommendation). Data quality is a key requirement in respect to:

- consistency
- accuracy
- integrity
- availability
- geo-rectification

Geo-rectification of data leads to standardization and is of critical importance. Decision-support tools are heavily reliant on geographic information.

How do you represent what the system is doing so that the **human is comfortable with the system’s actions**. The National Missile Defense system is an example where action is automatic. The system should **delineate between defensive and offensive operations**, where defense is almost always automatic while offense is not. We should not allow computers to make your plan, but let the computer tell you the implications of your plan.

Dealing with data in the computer does not work. **Computers must deal with information**. More sophisticated tools such as agents can use their reasoning capabilities only on the basis of information. A clear distinction needs to be made between data, information and knowledge. Marine Corps Intelligence has definitions for data, information and knowledge, as follows:

Data: Numbers and words without relationships (i.e., facts).

Information: Data with relationships.

Knowledge: Inferences drawn from information.

Customization of the user-interface is not so much a user-interface issue but a deeper issue of *customization of functionality*. In particular, decision-support systems need to be scalable (i.e., *first mile* requirements are different from MEF (Marine Expeditionary Force) requirements. Squad leader just needs a small subset of the decision-support tools available.

Input to decision-support systems should be *automated* as much as possible using sensors, GPS, and other means, with dynamic updating capabilities.

Decision-support systems will require a reassessment of who makes what decisions. For example, the focus of commanders is currently on planning, it should be on *execution* with *planning assistance* from decision-support systems.

Decision making can be learned and the *Decision Range* is a step in the right direction. The Decision Range should be enhanced and used at all levels.

Organizations need to be flexible to support hierarchical and flat organizational structures depending on need. Even in hierarchical organizations the *information needs to be accessible at all levels*.

Theme B: *Appropriate R&D Directions*

1. Integrating Simulation and Optimization Techniques

As collaborative decision-support systems become more widespread, the variety of applications is rapidly increasing. How will future systems combine such approaches as optimization to provide for the rapid development of alternatives to support the planning function of a collaborative decision support system? What other approaches/techniques are likely candidates for linkage to these systems?

2. Integrating External Applications

Collaborative decision-support systems will continue to be crippled by the requirement for software translators until the initial effort focuses on capturing and recording information rather than data. These translators enable two-way communication between legacy systems and the object-serving communication facilities at the heart of the collaborative agent-based systems. Could a set of tools be designed which would allow the capture of information on entry into the system? Could it be designed with an ease of use sufficient for mass appeal? How? When?

3. Assessing Uncertainty, Risk and Opportunity Costs

Measuring risk and opportunity cost are important closely related functions. Risk is sometimes characterized as the probability that an event will occur multiplied by the consequences. Opportunity cost is the price of executing a course of action measured in terms of the actions foregone in doing so. How can these important functions be usefully incorporated into collaborative decision-support?

Discussion Items:

Funding constraints require ***leveraging of industry products***. Industry appears to be ahead of the government/military.

The budgeting and ***acquisition process is too long*** and insensitive to changes. A spiral model based on incremental fielding and testing would serve the military better.

Need to increase the ***visibility of decision-support systems*** (DSS) research and development efforts DoD- wide.

Human ***decision making skills*** and the ***role of training*** need to be further examined. As decisions move down, paradigms are going to have to change to allow these lower level individuals to actually make the decisions and remove the layers above the decision makers.

Need for ***research to examine the integration of simulation and optimization techniques***. The Army is developing a collaboration server facility (written in Java) that allows various planning

tools to share results over a single comprehensive view, with single element ownership to facilitate the updating of data objects. What does optimization mean in this context? It would probably be a better strategy to apply collaborative agents rather than optimization techniques. The ***relationships are usually too complex for the application of standard optimization techniques***. The user is continuously in a dual planning and execution cycle. Mathematical optimization does not apply under such dynamic conditions.

There is a need for ***research into discrete value systems*** (i.e., one dollar does not mean the same thing to everybody). We must take into account the notion of time variation (i.e., a change one month out is inexpensive compared to a change one day out).

There is a ***need to research the assessment of uncertainty, risk and opportunity costs***. We do not normally assess risk in terms of information system security. Industry undertakes risk calculations. Perhaps risk should be dealt with at the local level. ***Planning level risks are not adequately accounted for currently***.

Theme C: *System Design Requirements*

1. *Broad System Design Guidelines*

Three fundamental guiding principles have emerged in recent years for the design of collaborative decision-support systems: internal representation of information rather than data; human-computer collaborative interaction rather than automation; and, problem solving tools rather than hard-coded solutions. What are the current obstacles to achieving an acceptable measure of success in each of these areas? Are there other equally important system design guidelines?

2. *Standardization and Agent Languages*

In theory, standardization has always appeared to be an effective method for insuring interoperability among disparate software applications. In practice standardization has seldom delivered on its promises. There are essentially two paths to standardization: dominance by a single commercial vendor (e.g., Microsoft); and, voluntary cooperation by several commercial vendors with or without government support. What are the alternatives to standardization (e.g., intelligent interfaces)? What is the future of agent languages? Are there software system areas in which standards are of critical importance?

3. *The Knowledge Acquisition Bottleneck*

In the 1970s Ed Feigenbaum at Stanford University drew attention to the 'knowledge acquisition bottleneck' as a significant obstacle in the development of expert systems. Does the emphasis on ontology for the representation of information in collaborative decision-support system aggravate or ameliorate this obstacle? What are the steps in formalizing the ontology of an application area? Can any of these steps be automated?

4. *Object-Serving Communication Facilities*

Responsive object-serving communication facilities that can operate with reliability in a distributed environment are a prerequisite for collaborative decision-support systems. What are the current technical limitations faced by such facilities, what are the near term solution opportunities, and what are the emerging longer term technologies that are expected to mitigate the current limitations?

5. *Effective Agent Collaboration and Planning*

Agents have been shown to be able to: monitor events; communicate with each other and users in a collaborative mode; deliver and request services; send and receive information from external systems; reason about the impact of information changes; access databases; automatically generate explanations of how they arrived at conclusions; undertake planning functions; and, accomplish low level learning capabilities. There is at least an equal need for agents that detect the absence of

information (e.g., no position reports received from a certain region in the battlespace for the past eight hours) and the absence of normally expected conditions (e.g., no fuel tankers sighted for days in the vicinity of an enemy armored battalion). What are the intrinsic limitations and prospects for the development of 'Not' agents?

Discussion Items:

There is a need for some standards. In particular data must be ***geo-rectified***.

There is a paramount ***need for graceful degradation*** and redundancy.

There appears to be a significant effort involved in building ***information models*** in the computer (e.g., finding subject matter experts, dealing with the knowledge acquisition bottleneck, and so on). What is really needed is a universal ontology to support, for example, meaningful Internet searches. ***Anything going into database should be in object form.***

Decision-support systems will have ***many kinds of agents***, some will be mathematics-based rather than collaborative. In order for agents to meet the requirements of the users they should have a common method for communicating amongst each other. Our own language is a form of standardization that is evolving. This allows us to perform a diverse set of functions. However, ***agents need to be able to derive information from free-text.***

The ***user-interface*** of a decision-support system needs to support not only ***voice*** and ***text***, but also ***biometrics*** to reflect the state of the user.

Need to understand the ***actual capabilities and requirements of the user.***

- Broad System Design Guidelines – need to get technology out of requirements generation.
- Need to be able to modify requirements documentation as necessary by priority or technology.
- Need for an evolutionary acquisition approach to technology (i.e., the acquisition budgeting process should be changed sooner rather than later).
- Emphasis should be placed on more functional requirements documentation.

Actually we should not refer to decision-support but rather ***cognitive support***. Decision-support implies that the computer makes decisions, while cognitive support suggests more correctly that the computer prepares the information so that the human can make more effective decisions.

Theme D: *Communication Infrastructure*

1. *Reliable Data Feeds*

Reliable electronic pathways and assured access to data and information are essential if agent-based systems are to provide useful, accurate inferences and implications to key decision makers and staffs. Currently, these essential conditions do not apply equally to all activities during a crisis or contingency. Accordingly, in which functional areas of contemporary contingency execution can we anticipate that these communication infrastructure conditions will be adequate? Given the answer to the first question, where can the application of agent-based collaborative systems make the most useful contributions?

2. *Redundancy and Graceful Degradation*

That key communications will experience interruptions is certain. How can system design alternatives mitigate the impact of such interruptions? Can the system 'remember' the last situation prior to interruption? What other agent-based capabilities could be designed to assist with this problem (e.g., linked local nets, etc)? Is the creation of a 'system continuity agent' a realistic possibility? Such an agent would monitor communication links and seek to establish alternative flows.

3. *Alternatives for the 'Last Mile'*

The 'last mile', 'last hundred yards' and 'last ten feet' all express the challenge of establishing and maintaining robust communication links to the engaged units, especially small units in urban or complex terrain. What new technologies offer potential solutions to this challenge? What are their implications for the design of collaborative decision-support systems?

4. *Access Authentication and Security*

The need for electronic security is receiving increasing attention in both the military and commercial arenas. Existing security strategies, methods and policies for the protection of military data rely heavily on the physical separation of classified and unclassified systems. What are the specific security challenges posed by the new generation of integrated, distributed, collaborative decision-support systems? What tasks can be performed by computer-based agents to secure such systems from unauthorized intrusions? What are the opportunities (if any) for agent-based counterintelligence activities?

Discussion Items:

The *last mile* is really the *first mile* because information comes from the bottom up. While the bottom levels have the best information they often lack context.

Power unit limitations for the *first mile* are still a major technological problem.

There is a need for *wireless, broadband communication* facilities to support *voice* and *data*. Currently there is a disconnect between voice communication from the regimental level downward and data communication from the division level upward. Data should be pushed all the way down.

Security needs to be refocused from *communications* to *current data* (i.e., the focus of security in Vietnam was on secure communications).

There is a great potential for *electronic warfare* within a decision-support environment (i.e., from the viewpoint of both sides).